

# Design Criteria Manual for Stormwater and Landscaping



Effective June 2021

May 2021



SANTA CLARA VALLEY TRANSPORTATION AUTHORITY

# DESIGN CRITERIA MANUAL FOR STORMWATER AND LANDSCAPING

**Prepared for:**

Santa Clara Valley Transportation Authority  
3331 North 1<sup>st</sup> Street  
San Jose, CA 95134

| STORMWATER AND LANDSCAPING<br>DESIGN CRITERIA MANUAL | REVISION CONTROL |                |                  |
|--|------------------|----------------|------------------|
| Original Date:                                       | Revision Date    | Version Number | SUPERCEDES       |
| 06/30/2015   | N/A              | Rev.0          | N/A              |
| 07/01/2019   | N/A              | Rev.1          | 6/30/2015 Manual |
| 06/07/2021   | Final            | Rev.2          | 7/01/2019 Manual |



## CONTENTS

|  |    |
|--|----|
| Design Criteria Manual for Stormwater and Landscaping . . . . .                    | ii |
| 1. INTRODUCTION AND GUIDE TO USING THIS MANUAL . . . . .                           | 1  |
| 1.1 Background and Applicable Stormwater Permits . . . . .                         | 1  |
| 1.2 Manual Purpose . . . . .   | 2  |
| 1.3 Manual Use . . . . .   | 3  |
| 2. REGULATORY AND POLICY REQUIREMENTS . . . . .                                    | 6  |
| 2.1 CGP Permit- During-Construction Requirements . . . . .                         | 6  |
| 2.2 MS4 Permit- Post-Construction Requirements . . . . .                           | 7  |
| 2.2.a Exemptions for Specific Project Types . . . . .                              | 7  |
| 2.2.b Small Projects: 2,500 Square Feet to 5,000 Square Feet . . . . .             | 8  |
| 2.2.c Regulated Projects: 5,000 Square Feet & Larger . . . . .                     | 9  |
| 2.2.d Roadway Projects . . . . .   | 9  |
| 2.3 Multi-Jurisdictional Projects. . . . .   | 10 |
| 2.3.a During-Construction requirements for Multi-Jurisdictional Projects . . . . . | 11 |
| 2.3.b Post Construction Requirements for Multi-Jurisdictional Roadways . . . . .   | 11 |
| 2.3.c Operations and Maintenance for Multi-Jurisdictional Projects . . . . .       | 11 |
| 2.3.d Complete Streets: A Special Type of Multi-Jurisdictional Roadways . . . . .  | 13 |
| 2.3.e Multi-Jurisdictional Transit Oriented Development Projects . . . . .         | 14 |
| 3. DURING-CONSTRUCTION DESIGN REQUIREMENTS AND MEASURES . . . . .                  | 15 |
| 3.1 ESCAPE or WPCP: For projects <1 Acre . . . . .                                 | 15 |
| 3.2 SWPPP: For projects >1 Acre . . . . .  | 16 |
| 3.3 During- Construction Temporary WPCD and Specifications . . . . .               | 16 |
| 3.3.a Temporary Water Pollution Control Drawings . . . . .                         | 19 |
| 3.4 Final Erosion Control Drawings and Specifications . . . . .                    | 24 |
| 3.4.a Erosion Control Drawings and Scheduling . . . . .                            | 24 |



3.5 Inspections, Sampling, and Reporting . . . . . 27

    3.5.a ESCAPE. . . . . 27

    3.5.b WPCP . . . . . 28

    3.5.c SWPPP . . . . . 28

3.6 Estimate and Bid Items for Temporary Water Pollution Control and Erosion Control . . . . . 30

4. POST-CONSTRUCTION DESIGN REQUIREMENTS AND MEASURES . . . . . 33

    4.1 CAD Standards . . . . . 34

    4.2 Small Projects: 2,500 to 5,000 Square Feet of Impervious Surface . . . . . 35

        4.2.a Site Design Runoff Reduction Measures . . . . . 35

            4.2.a.1 Soil Quality, Tree Preservation, or Stream Setbacks . . . . . 36

            4.2.a.2 Porous/Permeable Pavement . . . . . 37

            4.2.a.3 Self-Retaining Areas . . . . . 38

            4.2.a.4 Green Roofs . . . . . 38

            4.2.a.5 Rain Barrels & Cisterns. . . . . 39

        4.2.b Runoff Reduction Water Balance . . . . . 39

    4.3 Regulated Projects: 5,000 Square Feet or more of Impervious Surface . . . . . 39

        4.3.a Post-Construction Source Control BMPs . . . . . 40

        4.3.b Runoff Reduction Measures . . . . . 42

        4.3.c Stormwater Treatment Measures . . . . . 43

            4.3.c.1. Bioretention Facilities . . . . . 43

            4.3.c.2 Flow-Through Planter . . . . . 44

            4.3.c.3 Bioretention Facility & Flow-Through Planter Sizing Criteria . . . . . 45

            4.3.c.4 Bioretention Facility Alternatives . . . . . 47

        4.3.d Stormwater Treatment Water Balance . . . . . 48



4.4 Trash Control Requirements . . . . . 49

    4.4.a Trash Full Capture Systems . . . . . 50

    4.4.b Multi-Benefit Treatment Systems . . . . . 51

4.5 Operation and Maintenance Manual . . . . . 53

4.6 Alternative Post Construction Stormwater Management Program . . . . . 54

5. LANDSCAPING REQUIREMENTS . . . . . 56

    5.1 Planting Guidelines. . . . . 56

    5.2 Irrigation Guidelines . . . . . 56

6. RESOURCES AND LINKS . . . . . 57

7. ACRONYMS . . . . . 59

8. REFERENCES . . . . . 60

9. ACKNOWLEDGMENTS. . . . . 61

ATTACHMENT A: APPLICABLE VTA POLICIES . . . . . 62

    A1: VTA Sustainable Landscaping Policy . . . . . 63

    A2: VTA Green Building Policy. . . . . 68

    A3: VTA Complete Streets Policy . . . . . 73

ATTACHMENT B: VTA PLANTING GUIDELINES . . . . . 88

    B1: VTA Planting Guidelines . . . . . 89

    B2: Comparison of VTA Tree Planting Guidelines to SCVURPPP Tree Guidelines . . . . . 136

    B3: Comparison of VTA Understory Planting Guidelines to SCVURPPP Understory Guidelines . 140

ATTACHMENT C: VTA IRRIGATION GUIDELINES . . . . . 151

ATTACHMENT D: SWCP TEMPLATES . . . . . 164

    D1: SWCP Template for Small Projects . . . . . 165

    D2: SWCP Template for Regulated Projects . . . . . 178

ATTACHMENT E: SITE DESIGN RUNOFF REDUCTION CHECKLISTS . . . . . 209

ATTACHMENT F: VTA SIGNOFF FOR STORMWATER AND LANDSCAPING DESIGN . . . . . 220



ATTACHMENT G: SMARTS USER GUIDE . . . . . 226

ATTACHMENT H: OWP LID SIZING TOOL USER GUIDE . . . . . 241

ATTACHMENT I: CAD STANDARD DESIGN CRITERIA . . . . . 250

ATTACHMENT J: POST-CONSTRUCTION STANDARD DETAILS, SPECIFICATIONS, AND  
GUIDANCE . . . . . 257

    J1: LID Standard Details (adapted from CASQA) . . . . . 259

    J2: Post-Construction BMP Design Guidance . . . . . 315

ATTACHMENT K: BIORETENTION FACILITY SAFETY SIGNAGE . . . . . 323

ATTACHMENT L: O&M PLAN . . . . . 325

    L1: O&M Plan Template . . . . . 326

    L2: Sample O&M Plan . . . . . 347

ATTACHMENT M: VTA SWPPP SPECIFICATION TEMPLATES . . . . . 381

ATTACHMENT N: ESCAPE SPECIFICATION . . . . . 401

    N1: ESCAPE Specification . . . . . 402

    N2: ESCAPE Template . . . . . 418

ATTACHMENT O: SAMPLE WATER POLLUTION CONTROL DRAWINGS . . . . . 427

ATTACHMENT P: VTA LANDSCAPING AND STORM WATER REQUIREMENTS FREQUENTLY ASKED  
QUESTIONS . . . . . 437

## 1. INTRODUCTION AND GUIDE TO USING THIS MANUAL

### 1.1 Background and Applicable Stormwater Permits

In February 2013, the California State Water Resources Control Board (SWRCB) adopted a renewed Phase II General Permit for Storm Water Discharges from Small Municipal Separate Storm Sewer Systems (MS4s). The MS4 permit became effective on July 1, 2013 and designated the Santa Clara Valley Transportation Authority (VTA) as a “Non-Traditional” MS4.

“Traditional” MS4s are cities, counties, and drainage and flood control districts that own and operate surface and sub-surface storm drain systems. Depending on their size, these traditional MS4s may be regulated in Santa Clara County as a “Phase I permittee” under the Municipal Regional Permit (MRP) or under the Phase II Permit. Nontraditional MS4s are operators of substantial storm drain systems that are owned by state or federal government entities, such as VTA, BART, Caltrain, or California State University campuses. Requirements specific to non-traditional MS4s are contained predominantly in Section F of the MS4 permit.

For VTA, the MS4 permit is administered internally through a multi-division effort. VTA Environmental Programs administers the MS4 permit. The Engineering and Project Delivery (EPD) supports the design and construction implementation elements



of the MS4 permit and the Statewide Construction General Permit (CGP) for Stormwater (2009-0009-DWQ). It is the responsibility of each design Project Manager to ensure that capital projects adhere to the permit compliance requirements under the MS4 and CGP permits, so that VTA can certify compliance using the State Water Board's Stormwater Multi-Application Reporting and Tracking System (SMARTS). SMARTS data is publicly available; thus, compliance can also be monitored by the public.

## 1.2 Manual Purpose

The purpose of this manual is to assist and provide guidance to planners and engineers (designers) in incorporating stormwater pollution prevention methods to better meet the CGP and MS4 permit requirements, as well as their goals. Use of this manual will aid the designer in incorporating stormwater features that meet VTA requirements pertaining to the treatment of stormwater runoff and post-construction water pollution and erosion control. The design criteria included also provides guidance for contractors during the construction phase of the contract so that they can better achieve permit requirements.

However, designers should realize that all project site conditions are different and that strict adherence to any manual or guidebook will not necessarily achieve the end goal of eliminating and/or reducing water pollution by the project. A unique combination of BMPs and site-specific modifications may be necessary to be truly successful.

Using this manual as a guide will help designers meet VTA criteria for the design of stormwater quality best management practices (BMPs) during construction and post-construction and provide guidance in the implementation and maintenance of such BMPs. Following the design criteria will enable designers to plan, design, construct and maintain BMPs to:





- Comply with the during-construction CGP requirements.
- Comply with the post-construction MS4 permit requirements.
- Develop design practices and principles that meet the requirements while minimizing project costs.
- Develop Source Control Measures that use existing VTA programs and materials to the maximum extent practical.
- Implement Site Design Runoff Reduction Measures and Stormwater Treatment Measures to minimize or eliminate the volume of runoff leaving the project site.
- Establish consistency across VTA for CGP and MS4 permit compliance.
- Establish consistent implementation of VTA's Sustainable Landscaping Policy, Green Building Policy, and Complete Streets Policy (included as **Attachment A**)

## 1.3 Manual Use

This manual is a guide for designers to help them achieve permit compliance. The manual addresses the design of during-construction BMPs, the design of post-construction BMPs– including source controls and runoff reduction strategies– and the required documentation for both phases. **However, designers are ultimately responsible for their design and its compliance with all permit requirements. Sole reliance on this manual should be avoided.**

All projects, regardless of size, must address construction stormwater runoff. During the construction phase, temporary BMPs are designed to reduce sediment and other pollutants from entering or discharging from the site. A properly designed project identifies the pollutant sources and the means to reduce or eliminate pollutants from discharging from the site. This manual serves as a guide to identify and implement the appropriate BMPs and comply with the required construction documentation.



**Exhibit 1:** Outline of Stormwater Design Process

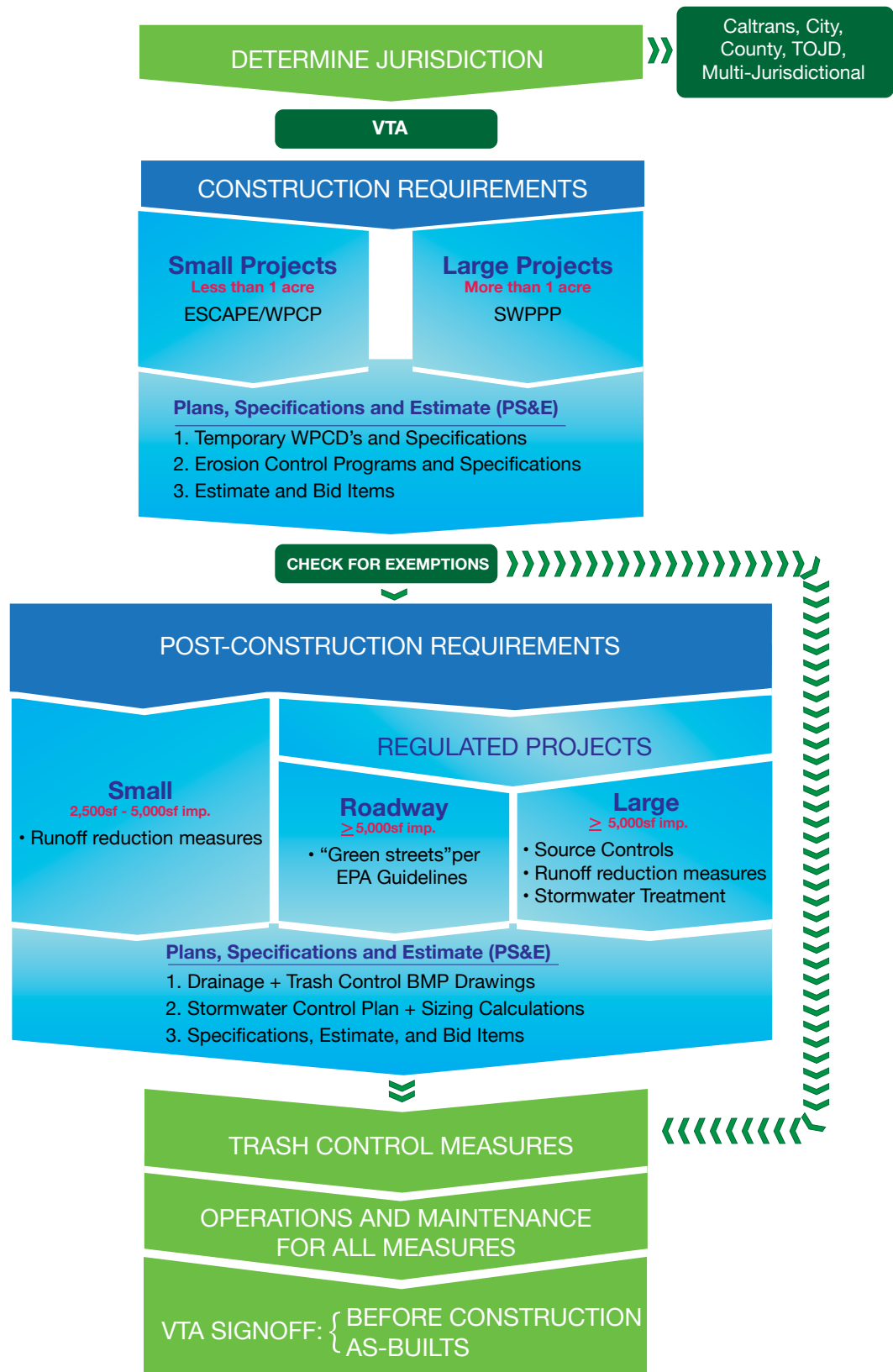



Projects may require permanent post-construction stormwater BMPs. These projects are separated into three categories: Small (projects that create and/or replace between 2,500 to 5,000 square feet of impervious surface), Regulated (projects that create and/or replace more than 5,000 square feet of impervious surface), or Roadway/Linear Underground/Overhead Utility projects. Although some of the design requirements apply to both the Small and Regulated projects, the design criteria, documentation, and BMP selection process varies. These differences are detailed below in **Section 2**. To properly use this manual there are several templates and checklists included as attachments. They include the Stormwater Control Plan (SWCP) Templates for Small and Regulated Projects (**Attachments D1 & D2**), Site Design Runoff Reduction Checklists (**Attachment E**), and the Template O&M Manual (**Attachment L1**). Designers must use these resources to properly design a project in compliance and complete the VTA project signoff process (**Attachment F**). Refer to Exhibit 1 and **Attachment P** for an overview of the design process, in accordance with the different construction and post-construction requirements. **Attachment P** contains a 6-page summary of this manual.

Additionally, there are numerous external resources available to assist with the project design, such as the Santa Clara Valley Urban Runoff Pollution Prevention Program (SCVURPPP) C.3 Handbook. Links to this and other useful resources are included in the *Resources and Links* section (**Section 6**).

## 2. REGULATORY AND POLICY REQUIREMENTS

### 2.1 CGP Permit- During-Construction Requirements

Designers must specify what construction BMPs are anticipated to address both erosion control (keeping soils in place) and sediment control (stopping soils that have migrated offsite) in accordance with the CGP. Erosion control and sediment control measures are implemented to avoid stormwater runoff pollution. To ensure effective implementation of the CGP, the contractor must prepare a Stormwater Pollution Prevention Plan (SWPPP) for all projects that disturb more than 1 acre – and update the designer’s Erosion and Sediment Control Action Plan Element (ESCAPE) for all smaller VTA projects (template found in **Attachment N**). Designers must include detailed requirements to ensure correct implementation of construction BMPs in the contract plans and specifications. Designers must also include the costs of such BMPs in the contract bid/pay items. Refer to **Section 3** for during-construction design requirements and measures.

## 2.2 MS4 Permit- Post-Construction Requirements

Section F.5.g of the MS4 permit divides the post-construction requirements into five categories:

1. Exempt Projects
2. Projects that create or replace between 2,500 square feet and 5,000 square feet of impervious surface
3. Projects that create or replace more than 5,000 square feet of impervious surface
4. Road and linear underground/overhead utility projects (LUPs)
5. Alternative Post-Construction Storm Water Management Programs for multi-benefit projects

The following section elaborates on the requirements, conditions, and exclusions for the project categories listed above. Refer to **Section 4** for specific post-construction design requirements and measures.

### 2.2.a Exemptions for Specific Project Types

Certain types of projects that would otherwise be considered Small or Regulated Projects are exempt from the post-construction stormwater requirements:



**Figure 1:** Impervious Trail Exception



- Interior remodels and demolition projects that do not modify the existing footprint;
- Routine maintenance and repair projects that maintain the original purpose and footprint of the facility, such as:
  - Exterior wall surface replacement;
  - Pavement grinding and resurfacing of existing roadways and parking lots;
  - Routine replacement of damaged pavement, such as pothole repair, or short noncontiguous sections of roadway pavement that are less than 5,000 square feet;
- Re-roofing, regardless of whether it is a full roof replacement or an overlay;
- Excavation, trenching, and resurfacing associated with linear utility projects;
- Construction of new sidewalks, pedestrian ramps, or bicycle lanes on existing roadways;
- Sidewalks and bicycle lanes built as part of new streets or roads when they are graded to direct runoff to adjacent vegetated areas;
- Sidewalks, bicycle lanes, and trails when constructed with permeable surfaces; and
- Impervious trails when they are graded to direct runoff to adjacent vegetated areas or other non-erodible permeable areas.

**Figure 1** shows an impervious trail designed such that stormwater flows off onto adjacent vegetation.

## 2.2.b Small Projects: 2,500 Square Feet to 5,000 Square Feet

Projects that create or replace at least 2,500 square feet and less than 5,000 square feet of impervious surface are required to include runoff reduction post-construction BMPs. The designer must use calculations to quantify the runoff reduction resulting from implementation of the post-construction BMPs. The goal is to achieve no increase in runoff from the project site. Refer to **Section 4.2.b** for more information on this calculation.



## 2.2.c Regulated Projects: 5,000 Square Feet & Larger

Projects that create or replace 5,000 square feet or more of impervious surface are required to include post-construction BMPs and are required to achieve no increase in runoff from the project site. These projects must also implement measures for source control, runoff reduction/site design, stormwater treatment, and baseline hydromodification management. Refer to VTA's Green Building Policy (**Attachment A**) and **Section 4.3.d** for more information on this calculation.

## 2.2.d Roadway Projects

Road and linear underground/overhead utility projects (LUPs) are not required to implement Small Project post-construction stormwater requirements, even if creating over 2,500 square feet of impervious surface. Road and linear underground / overhead utility projects that create 5,000 square feet or more of newly constructed, contiguous, impervious surface are classified as Regulated Projects and must comply with the post-construction stormwater requirements of **Section 4.3** in this manual. However, when the stormwater runoff from the design storm event (85<sup>th</sup> percentile 24-hour storm) cannot be infiltrated on-site, stormwater runoff must be managed using practices identified in the U.S. Environmental Protection Agency's (USEPA) *Managing Wet Weather with Green Infrastructure Municipal Handbook Green Streets* (EPA 833-F-08-009, December 2008), to the extent feasible. Some typical design options include minimizing street widths (reducing impervious area), and use of vegetated swales, tree planters, permeable pavement, and bioretention basins.



The Construction General Permit and MS4 project define LUPs differently, but for MS4 Permit purposes, types of LUP projects include:

1. Construction of new streets or roads, including sidewalks and bicycle lanes, built as part of the new streets or roads which create 5,000 square feet or more of impervious surface.
2. Widening of existing streets or roads with additional traffic lanes.
  - a. Where the addition of traffic lanes results in an alteration of more than 50 percent of the impervious surface (5,000 square feet or more) of an existing street or road, runoff from the entire project, consisting of all existing, new, and/or replaced impervious surfaces, must be included in the treatment system design.
  - b. Where the addition of traffic lanes results in an alteration of less than 50 percent (but 5,000 square feet or more) of the impervious surface of an existing street or road, only the runoff equivalent from new and/or replaced impervious surface of the project must be included in the treatment system design.

Specific exclusions to the post-construction MS4 permit requirements are:

1. Sidewalks built as part of new streets or roads and built to direct stormwater runoff to adjacent vegetated areas;
2. Bicycle lanes that are built as part of new streets or roads that direct stormwater runoff to adjacent vegetated areas;
3. Impervious trails built to direct storm water runoff to adjacent vegetated areas, or other non-erodible permeable areas – preferably away from creeks or towards the outboard side of levees; and
4. Sidewalks, bicycle lanes, or trails constructed with permeable surfaces.

## 2.3 Multi-Jurisdictional Projects

VTA often has projects on city or county property – or projects in collaboration with Caltrans – all of which may have different design requirements than are found in this manual, because the cities are regulated by the Phase 1 MS4 permit (called the Municipal Regional Permit or MRP), and Caltrans projects are subject to the Caltrans NPDES permit. Consult with the VTA Environmental Programs MS4 Lead for these multi-jurisdictional projects.





## 2.3a During-Construction requirements for Multi-Jurisdictional Projects

For multijurisdictional projects, VTA remains the Legally Responsible Person under the CGP for all projects they administer. However, to adhere to the construction requirements, the erosion control plan must follow the template of whichever right-of-way/ jurisdiction the project is in. VTA uses the California Stormwater Quality Association (CASQA) format SWPPP Template for projects greater than 1 acre and an internally developed ESCAPE for projects less than 1 acre (see **Attachment N**). However, if a less than 1-acre project is in Caltrans' right-of-way, then a Caltrans format Water Pollution Control Plan (WPCP) must be prepared, and if a greater than 1-acre project is in Caltrans' right-of-way, then the SWPPP must follow the Caltrans template/format.

## 2.3.b Post Construction Requirements for Multi-Jurisdictional Roadways

For post-construction requirements, the SCVURPPP guidelines are adhered to within the county and cities right-of-way areas, whereas Caltrans has their own design standards that are applied within Caltrans property, following the Caltrans Stormwater Control Plan (SWCP) format.

## 2.3c Operations and Maintenance for Multi-Jurisdictional Projects

In the case of multi-jurisdictional projects, the designer must map all stormwater facilities and determine the operations and maintenance (O&M) requirements during the design phase. Designer should strive to keep all runoff and treatment facilities within each respective agency's right of way (ROW). Stormwater from each agency's ROW should be kept separated in designated MS4 drainage facilities.



At a minimum, the 4% rule for bioretention basins shown in the 35%/conceptual design drawings. In 65% drawings use flow-based and/or volume-based calculations to support the sizing and confirm utility conflicts and selected locations are appropriate with grading and drainage of the area. Designer's final/100% drawings must be included in the Stormwater Management Plan.

The O&M for surface and subsurface features must be indicated in clear exhibits created by the Designer to accompany the O&M Manual. The VTA O&M Manual template is provided in **Attachment L1**. Surface and subsurface piping MS4 exhibits must be generated during design and must clearly outline O&M responsibilities. The exhibits should be color coded or be clearly labeled by agency responsible for maintenance based on where the runoff originates. For example:

- City (MRP applies)
- VTA (Non-Traditional Phase II MS4 applies)
- County (MRP applies)
- Caltrans (Caltrans MS4 applies)
- BART (Non-Traditional Phase II MS4 applies)
- Caltrain (Non-Traditional Phase II MS4 applies), etc.
- TOD private contractor, HOA, or other long-term lessee

The Designer must include the draft O&M Manual and exhibits to VTA for review and approval with the 65%, 95%, and 100% design submittals or equivalent milestone submittals. VTA may use the exhibits created as part of the negotiations for the cooperative agreements, where applicable. A sample O&M manual including all needed O&M exhibits is included from the Silicon Valley Berryessa Extension Project as **Attachment L2**.

In the cases where there is a commingled flow and it is impossible, due to site constraints, to separate MS4 stormwater facilities by agency, Designer must inform VTA of the conflict and the proposed design solution, so it may be addressed in an agreement.



**Figure 2:** Complete Street in Urban Area with tree well and bioretention features

Credit: [www.vta.org/projects-and-programs/complete-streets](http://www.vta.org/projects-and-programs/complete-streets)

### 2.3.d Complete Streets: A Special Type of Multi-Jurisdictional Roadways

Post-construction requirements can be woven into a seamless streetscape that meets stormwater requirements and the needs of multiple travel modes. Streets in city right-of-way may have particular requirements set forth in the SCVURPPP Green Stormwater Infrastructure Handbook. Additionally, VTA has long promoted Complete Streets; streets that are planned, designed, funded, constructed, operated, and maintained for the safe travel of all users, of all ages and abilities. They are streets where designs are context sensitive, which incorporate sustainable infrastructure and stormwater features in a balanced network approach, and which prioritize the safety, comfort, and convenience of pedestrians, bicyclists, and transit riders (including access and operations), as appropriate for the local context, while providing safe accommodations for motorists and other roadway users. See **Figure 2**, above, for an illustration of a complete street (or green street) in an urban setting.

Designers should consult with the VTA MS4 Program Manager for these types of multi-jurisdictional projects to determine which permit requirements apply. See **Attachment B** for VTA's Complete Street Policy, adopted in December 2017.

### 2.3e Multi-Jurisdictional Transit Oriented Development Projects

Designing a Transit Oriented Development (TOD) is a special case of a multi-jurisdictional project, where VTA will keep the underlying fee but the project will need to meet the applicable city's building department and MS4 requirements. **Figure 3** below is an example design drawing using landscaping and bioretention facilities to treat stormwater drainage management areas at a TOD type facility.



**Figure 3:** Transit Oriented Development. VTA's Blossom Hill Station Site planned for TOD. Note that the TOD areas where the MRP Section c.3 will be applied and the VTA areas where the MS4 permit applies are clearly delineated by the designer.

### 3. DURING-CONSTRUCTION DESIGN REQUIREMENTS AND MEASURES

The plans, specifications, and estimate contract packages prepared by designers must require contractors to implement good practices for stormwater on projects, regardless of their size. The complexity of implementation and requirements for design expand with increased disturbed soil area, as outlined in the following sections.

#### 3.1 ESCAPE or WPCP: For projects <1 Acre

For projects that disturb less than 1 acre, an ESCAPE is required on VTA projects, and a Water Pollution Control Plan (WPCP) is required on Caltrans oversight/highway projects. Both documents are similar in nature and require BMPs to be used that are site-specific. **Attachment N** contains the required specification template for VTA projects “Temporary Water Pollution Control” specification and the ESCAPE template for Designers to complete and attach to the specification at 35%, 65%, and 95% design. This manual assists designers with the selection of compliant BMPs. The Caltrans WPCP Template can be found on the Caltrans website: <https://dot.ca.gov/programs/construction/storm-water-and-water-pollution-control/manuals-and-handbooks>

**For projects less than 1 acre, designers must complete the VTA Signoff for Stormwater and Landscaping Design (Attachment F) and submit the form with every major design submittal (i.e., 35%, 65%, 95%, and As-Built Record Documents after construction).**

### 3.2 SWPPP: For projects >1 Acre

All projects that disturb more than 1 acre require a Storm Water Pollution Prevention Plan (SWPPP) submittal and coverage under the CGP. CGP requirements are dependent on a project's Risk Level; therefore, it is important that designers understand what those requirements are and specify them at bid time. Designers must do a preliminary calculation of project Risk Level (based on project's location and soil types) and write the specification customized to the CGP requirements. To calculate Risk Level, designers need to know the site's soil characteristics (derived from the latitude and longitude), schedule of construction, and the receiving water that the storm drainage system discharges to at its downstream-most point. A SMARTS guide is included in **Attachment G** to assist with the Risk Level estimation. Contact the VTA Construction Contract Compliance Officer for additional assistance with the calculation.

**For projects greater than an acre, designers must complete the VTA Signoff for Stormwater and Landscaping Design (Attachment F) and submit the form with every major design submittal (i.e., 35%, 65%, 95%, and As-Built Record Documents after construction).**

### 3.3 During- Construction Temporary WPCD and Specifications

Designers must anticipate the during-construction conditions and project staging/phasing and outline the temporary BMPs that contractors will need during construction to protect water quality. The drawings and bid items/engineers' estimate must incorporate these quantities and be submitted to VTA in every major design submittal (i.e., 35%, 65%, & 95%).

The design should provide for adequate erosion control to prevent soils from becoming dislodged, perimeter sediment control to stop soils from leaving the site after they have mobilized, as well as non-stormwater management and waste and materials management. These minimum BMPs are required for all projects where soils are disturbed, regardless of project size, and, wherever possible, should be measured and paid as unit items in the contract documents. **Figure 4** shows one type of temporary erosion control installed along a slope adjacent to a creek. Non-plastic erosion control materials, such as jute blankets, are required by the CGP wherever possible, unless the protection is temporary/for individual storms. **Figure 5** shows temporary perimeter sediment control (silt fence) installed along a creek.

For Projects  
Greater than  
\$100 million

For VTA-administered construction projects of \$100 million or more, a dedicated QSD will be assigned by the contractor for the duration of the project so that adjustments to the SWPPP may be made in a timely fashion





**Figure 4:** Final site erosion controls with jute blankets and hydroseed.



**Figure 5:** Temporary Perimeter Sediment Control with silt fence

Designers are to determine what erosion and sediment control BMPs are required to address the project's runoff, as outlined below. The template Technical Specifications that must be used for all VTA SWPPP projects and ESCAPE projects can be found in **Appendix M** and **N**, respectively. These templates must be customized by designers to fit the project's specific needs and requirements. Any water pollution control items that are quantifiable should be added as unit items into the estimate.

Additionally, designers should be aware of the required temporary BMP implementation associated with protecting permanent post-construction BMPs during construction. Specifically, the construction of bioretention facilities requires BMP implementation as seen in **Figure 6** to ensure that sediment does not erode into and clog the facility's media layer. In addition to BMP installation, bioretention facilities require rigorous oversight during construction.



**Figure 6:** Bioretention basin is inadequately protected with only fiber rolls. Note the accumulated sediment filling the rock riprap and discoloring the soil media on the left half of the basin.



**Figure 7:** Bioretention basin is adequately protected from construction run-on using temporary hydromulch and erosion control blanket.





### 3.3.a Temporary Water Pollution Control Drawings

BMPs must be constructed per an approved engineering detail or equivalent standard detail. The following handbooks are referenced below for specific BMP cut-sheet details that may be included or referenced in the drawings:

- *California Storm Water Best Management Practice Handbook for Construction Activity* prepared by CASQA. This is available online at [www.casqa.org](http://www.casqa.org) for all CASQA members or subscribers.
- *Construction Site Best Management Practices (BMP) Manual* prepared by the California Department of Transportation (Caltrans). This is available online on Caltrans' website at: [www.dot.ca.gov/hq/construc/stormwater/manuals.htm](http://www.dot.ca.gov/hq/construc/stormwater/manuals.htm).

Designers are to use the Caltrans or CASQA standard designations for BMPs in CAD when drafting the Temporary Water Pollution Control Drawings (WPCD). Sample drawings illustrating these BMPs are included for reference in **Attachment N**.

For each project, designers must consider the following requirements in the plans, specifications, and estimate for stormwater pollution control, and include appropriate BMPs such as those outlined below on Temporary Water Pollution Control drawings for the contractor to bid on. Include adequate bid items for maintaining BMPs in the engineer's estimate and estimate of quantities.

- **Temporary Construction Entrance/Exits:** Designers should add a unit item and assume a conservative number of rock entrance/exits will be required for every ingress and egress point throughout the project. To estimate the quantity needed, assess the construction phasing and identify likely ingress and egress points for all traffic – and remember that different phases of a project may move or replace ingress and egress points on the project site to complete the work. Ensure that an appropriate number of properly constructed, Caltrans/CASQA detail rock entrance/exits are included in the estimate to prevent track-out of soils onto paved areas. Ensure that the technical specification states that there will be a deduction in payment for any entrance that is not placed or not maintained in a timely fashion (i.e., within 14 days of a VTA request). Refer to the TC-1 cut sheet in the CASQA or Caltrans handbook for proper construction details.



- Temporary Perimeter Protection** (silt fence, fiber rolls, gravel bags, etc.): Designers should add a unit item and assume a conservative number of linear feet of silt fence or fiber roll will be needed to surround all disturbed earth areas on the entire site. Even projects that occur on pavement but disturb soils need some type of perimeter control to ensure that sediment does not wash offsite into drain inlets. Note: No plastic mesh or netting is permitted on BMPs for VTA projects; specify fully biodegradable, not photodegradable, materials will be used. Provide for a way to pay for maintenance, which often involves replacing the fence/rolls, unless the damage was caused by the contractor. Deduct from the pay item for any BMP that is not placed or not maintained in a timely fashion (i.e., within 14 days of a VTA request). For silt fence, refer to the SE-1 cut sheet in the CASQA handbook or SC-1 Caltrans handbook. For gravel bag berms, refer to SE-6 cut sheet in the CASQA handbook or SC-6 Caltrans handbook.
- Slope protection** (Fiber rolls): Fiber rolls are required on all disturbed slopes on Risk Level 2 and 3 projects and are strongly advised on all projects. Designers should add a unit item and assume a conservative linear feet of fiber rolls on all slopes of the project. Refer to the SC-5 cut sheet in the CASQA or Caltrans handbook. They are to be placed at the top of the slope, face of the slope, and at grade breaks, per the following spacing (measured perpendicular to the slope):

**Table 1:** Critical Slope/ Fiber Roll Spacing Combinations

| Slope Percentage | Fiber roll spacing not to exceed |
|------------------|----------------------------------|
| 0-25%            | 20 feet                          |
| 25-50%           | 15 feet                          |
| Over 50%         | 10 feet                          |

No plastic mesh or netting is permitted in rolled or blanket products on VTA projects. Fiber rolls and erosion control blankets must be made from fully biodegradable, not photodegradable, materials. See **Figure 7**.



**Figure 8:** Fiber Rolls

- **Drain Inlet (DI) protection:** Designers should add a unit item and assume a conservative number of drain inlet protection devices will be needed. One approach to estimate the quantity is to count all existing and to-be-constructed DIs on the project, plus any immediately adjacent DIs near the project perimeter that may receive silty runoff. The DI protection inserts should be specified as pre-manufactured inserts, not filter fabric, and gravel bag berms as needed and in long drainage areas. Provide for a way to pay for maintenance, which often involves replacing the inserts. To estimate the replacement quantity needed, typically, designers assume that the DI protection must be replaced annually, at a minimum. Include adequate quantity and requirements to pay the contractor to place new protections as needed for site conditions. Deduct from the pay item for any DI protection that is not placed, replaced, or not maintained in a timely fashion (i.e., within 14 days of a VTA request). Refer to the SE-10 cut sheet in the CASQA handbook or the SC-10 cut sheet in the Caltrans handbook.
- **Temporary site stabilization prior to rain** (hydro-mulch, bonded fiber matrix, soil binder, etc.): Some type of soil stabilization will be needed for SWPPP projects prior to every rain storm and in any soil areas left inactive for 14 days. Risk Level 2 and 3 proj-



ects are required to stabilize even actively disturbed soil areas prior to rain. Designer's should add a unit item covering the entire site's disturbed soil area to be conservative. To estimate the quantity needed, one approach is to multiply this disturbed area by 4; to assume 4 applications (minimum) will be needed in any 6-month rainy season across the entire site. Multiply this by the number of winter seasons that the project will be active (i.e., assume the entire site will need 4 applications of mulch/stabilizer each winter). Deduct from the pay item for any stabilization that is not placed prior to rain or in a timely fashion (i.e., within 14 days of a VTA request for inactive areas). Refer to cut-sheets EC-3 through EC-8 in the CASQA handbook or cut-sheets SS-1 through SS-8 in the Caltrans handbook.

- **Concrete Waste Management & Washouts:** Concrete washouts must be constructed per an approved engineering detail (reference WM-8 cut sheet in Caltrans handbook, or equivalent standard details in drawings) and specify that no recreational kiddie pools will be used. To estimate the quantity of washouts required, designers should assume 1 washout/300 yards of concrete will be required at a minimum and include a unit item for washouts. Deduct from the concrete waste management pay item for any washout that is not placed properly, leaks, is overfilled, is moved prior to concrete residue solidifying, is not covered prior to rain, or that is not disposed of properly within a timely fashion after concrete residue solidifies.
- **Material storage areas and secondary containment:** For SWPPP projects, Designers should include a unit item for construction of at least 1 covered secondary containment area for non-visible pollutants (such as chemicals, hydraulic equipment, etc.).
- **Stockpile Protection:** Designer's should add a specific stockpile protection pay item. Require that any portion of a stockpile not actively being worked by the contractor within the last 14 days be covered. If there is a forecast rainfall, stockpiles are to be covered, and covers may only be removed for the portion of the pile actively being worked. Covers are to be immediately replaced when not actively working that section of a stockpile. Deduct from the pay item for any deficiencies not addressed within 72-hours of a VTA request. Refer to the cut sheet WM-3 in the CASQA or Caltrans handbook.



- **Other Items:** SWPPP/Construction site maintenance items that are not quantifiable may be grouped as a separate lump sum from the unit items (such as scheduling, waste management, etc.).

Below, **Table 2** indicates the items that must be included on the Temporary Water Pollution Control Drawings, for the designer’s use.

**Table 2:** Required Information for Temporary Water Pollution Control Drawings

| Included on Drawing:<br>Plan & Sheet No. | Required Element   |
|--|--|
|  | The project’s surrounding area (vicinity)  |
|  | Site layout  |
|  | Construction site boundaries   |
|  | Drainage areas   |
|  | Discharge locations  |
|  | Sampling locations   |
|  | Areas of soil disturbance (temporary or permanent)   |
|  | Active areas of soil disturbance (cut or fill)   |
|  | Locations of runoff BMPs   |
|  | Locations of erosion control BMPs  |
|  | Locations of sediment control BMPs   |
|  | Active Treatment System location (if applicable)   |
|  | Locations of sensitive habitats, watercourses, or other features that are not to be disturbed (Environmentally Sensitive Areas or ESAs)  |
|  | Locations of all post construction BMPs (separate sheet from the temporary BMPs). If using bioretention, then include the calculations on sheet or reference where the calculations can be found on the sheet. |
|  | Waste storage areas  |
|  | Vehicle storage areas  |
|  | Material storage areas   |
|  | Entrance and Exits   |
|  | Fueling Locations (if applicable)  |



### 3.4 Final Erosion Control Drawings and Specifications

Designers must include permanent BMPs that address post-construction site stabilization and erosion control, in addition to treatment of post-construction stormwater runoff as specified in the next section. Designers should allow for adequate quantities of stabilization BMPs in the drawings and Engineer's Estimate and these BMPs should be measured as unit items, if possible.

The Erosion Control drawings should provide for adequate permanent erosion control to prevent soils from becoming dislodged during construction and after construction. Designers must consider scheduling factors for BMP implementation, especially in conjunction with post-construction stormwater management. Final stabilization of the construction site must be reached, and an Operations and Maintenance (O&M) Plan (**Attachment L1**) must be implemented to file a Notice of Termination under the CGP.

Designers are to use the Caltrans or CASQA standard designations for BMPs in CAD when drafting the Erosion Control Drawings. Sample drawings illustrating these BMPs are included for reference in **Attachment N**.

#### 3.4.a Erosion Control Drawings and Scheduling

For each project, designers must consider the following final stabilization requirements in the plans, specifications, and estimate for stormwater pollution control, and include the following on Erosion Control Drawings for the contractor to bid on:

- **Final erosion control/site stabilization** (mulch, hydroseed, rock, plantings): Designers should include Erosion Control Plan drawings and pay items for final site stabilization, which are separate from the Temporary Water Pollution Control Drawings. Be aware of native plant policies and drought restrictions in VTA's Sustainable Landscaping Policy and VTA Planting Guidelines (**Attachment B**). Plan for non-vegetative stabilization, such as with mulch, erosion control blanket, or rock, wherever possible, to conserve water. Note: No plastic mesh or netting is permitted for BMPs/erosion control materials for VTA projects. Specify fully biodegradable, not photodegradable, materials will be used. If permanent hydroseed is used, all hydroseed shall be native species on VTA right of way (ROW) in accordance with VTA's Sustainable Landscaping Policy. Designers should include the location and plans for irrigation, if needed. Irrigation must comply with VTA's Sustainable Landscaping Policy, Green Building Policy (**Attachment A**), and **Section 5** Landscaping Requirements of this DCM, as well as **Attachment C** for designated matching irrigation products. Final site stabilization must be provided for all disturbed soil areas at the end of the job, including project soils, material storage areas, and soil off-haul areas. **Figure 9** shows recently applied hydroseed, a permanent BMP.



---

**Figure 9:** Hydroseed

---



- **Final slope stabilization:** Note that fiber rolls are required for final slope stabilization on all finished earthen slopes on Risk Level 2 and 3 SWPPP projects and are advisable on all finished projects. They are to be placed at the top of the slope, face of the slope, and at grade breaks, per the following spacing (measured perpendicular to the slope):

**Table 3:** Critical Slope/ Fiber Roll Spacing Combinations

| Slope Percentage | Fiber roll spacing not to exceed |
|------------------|----------------------------------|
| 0-25%            | 20 feet                          |
| 25-50%           | 15 feet                          |
| Over 50%         | 10 feet                          |

No plastic mesh or netting is permitted in rolled or blanket products on VTA projects. Fiber rolls and erosion control blankets must be made from fully biodegradable, not photodegradable, materials.

- **Scheduling:** Designers should include a schedule for erosion control implementation. The schedule should consider factors such as seasonal rains, hydroseed growing periods, availability of irrigation, construction phasing, type of post-construction stormwater treatment selected, and termination of the project's CGP coverage. For example, hydroseed application timing should be scheduled with the seasonal rains to allow the seed to germinate before the last charged day of the contract, and hydroseed stabilization is required to be established before runoff reaches stormwater treatment measures, such as bioretention basins. Erosion control should be implemented prior to the use of permanent stormwater treatment measures. As a result, completion of a contract in late spring or early summer may make hydroseed less desirable as a stabilization measure. Designers should include a Plant Establishment Period (PEP) which ensures erosion control plants will grow and thrive, and that the contractor will take remedial measures if plantings do not stabilize the site. Designers should consider the timing of the Notice of Termination and the Stormwater Management Plan when determining the PEP.





**Table 4** indicates items that must be included on the Erosion Control Drawings. For each project, designers should consult the other post-construction sections of this DCM to comply with the requirements of **Section F** of the Phase II MS4 permit.

**Table 4:** Required Information for Erosion Control Drawings

| Included on Drawing:<br>Plan & Sheet No. | Required Element  |
|--|---|
|  | Show site stabilization for all disturbed soil locations.   |
|  | Show plant locations. Plant list should comply with native plant policies and drought restrictions in VTA’s Sustainable Landscaping Policy.   |
|  | Show irrigation if needed. Irrigation should comply with VTA’s Sustainable Landscaping Policy, <b>Section 5</b> Landscaping Requirements of this DCM, and <b>Attachment C</b> for VTA Designated Matching irrigation Products.  |
|  | Show location of non-vegetative stabilization, such as mulch, erosion control blanket, or rock.   |
|  | Show location of vegetative stabilization, such as hydroseed.   |
|  | Consider scheduling: <ul style="list-style-type: none"> <li>• Hydroseed application should be scheduled with the seasonal rains.</li> <li>• Erosion control should be implemented prior to use of bioretention basins.</li> <li>• Include a plant establishment period, if applicable.</li> </ul> |
|  | Show fiber roll locations on all finished earthen slopes on the project.  |

### 3.5 Inspections, Sampling, and Reporting

Contractors are required to inspect, sample, and report on stormwater concerns and BMP implementation. See below for specific instructions for each type of project.

#### 3.5.a ESCAPE

Contractors are required to participate in joint inspections with VTA. In the Engineer’s Estimate, designers should assume weekly joint inspections will be performed and additional inspections for each rain event. The contractor must use the VTA’s preferred CloudCompli cloud-based software platform for performing inspections.



The contractor is responsible for submitting ESCAPE Amendments to VTA as project information or BMP implementation changes. Designers should assume annual amendments to the ESCAPE are required, at a minimum, in the Engineer's Estimate.

### 3.5.b WPCP

The contractor is required to fulfill Caltrans' inspection requirements. For the Engineer's Estimate, designers shall assume inspection frequencies as follows:

- Daily visual inspections
- Weekly inspections for Construction Site BMP maintenance
- Quarterly non-stormwater inspections
- Prior to a forecasted storm event
- At least once each 24-hour interval during an extended storm event
- After each CGP-defined qualifying rain event

The contractor is responsible for submitting WPCP Amendments to VTA as project information or BMP implementation changes. In the Engineer's Estimate, designers should assume annual amendments to the WPCP are required, at a minimum.

### 3.5.c SWPPP

Projects that have a SWPPP require inspections and sampling to comply with the CGP. The inspection frequency and sampling requirements are dependent on the project's Risk Level. SWPPP inspections are to be completed in CloudCompli, a cloud-based online platform for stormwater inspections and compliance monitoring. Users can consult the in-software guidance for how to use their software.

In the Engineer's Estimate, designers should assume a minimum of weekly inspections and additional inspections for each rain event. The contractor is responsible for all inspection and sampling data submission in SMARTS. Designers should include a pay item for SMARTS inspection and sampling data submission in the Engineer's Estimate to capture this effort.



If the project cost is greater than \$100 million, the contractor must additionally staff a VTA-approved, full-time, Qualified SWPPP Developer (QSD) and Qualified SWPPP Practitioner (QSP) for the duration of the project. Refer to VTA's (**Attachment M**) and customize the Template Technical Specifications as needed for CGP-compliant SWPPP inspections, sampling, and reporting.

The contractor is responsible for submitting an Annual Report into SMARTS each project year. In the Engineer's Estimate designers should assume, at a minimum, one CGP Annual Report for each year of work that occurs within a CGP permit year (July 1<sup>st</sup> - June 30<sup>th</sup>). Additionally, the contractor is responsible for submitting SWPPP Amendments into SMARTS as project information or BMP implementation changes. At a minimum, designers should assume annual amendments to the SWPPP are required each September in the Engineer's Estimate.

Lastly, at the end of the project, the contractor is responsible for submitting a Notice of Termination (NoT) within 90 days of project completion in SMARTS to discontinue coverage under the CGP. To file a NoT, the contractor must submit a final site map indicating the above required erosion control elements and submit photographs indicating that the site has been stabilized. Final stabilization can be reached by using one of the following CGP methods: The 70% final cover method; the Revised Universal Soil Loss Equation (RUSLE) or RUSLE2 method; or a custom method indicating that the site complies with the final stabilization requirements of the CGP. The NoT documentation must indicate that post-construction stormwater treatment features have been installed in correlation to the size of the project (see **Section 4.2.b & Section 4.3.d** of this manual), temporary BMPs have been removed, and a long-term O&M Plan has been established (see **Section 4.6** and **Attachment L**). Failure to reach final stabilization could result in continuation of CGP coverage and annual billing. Designer should include a pay item for submitting a Notice of Termination in the Engineer's Estimate.



### 3.6 Estimate and Bid Items for Temporary Water Pollution Control and Erosion Control

Designers are required to include the quantities shown on the Temporary Water Pollution Control Drawings and Erosion Control Drawings in the Engineer’s Estimate and bid items. After a bid is awarded, the Contractor’s Qualified SWPPP Developer (QSD) is responsible for customizing these, as needed to reflect the contractor’s means and methods, and is responsible for submitting these to VTA’s Legally Responsible Party (LRP) in the SWPPP submittal for approval, prior to the issuance of the Notice to Proceed.

Bid documents must include adequate specifications, unit items, and allowances in the cost estimate for ESCAPE/WPCP or SWPPP implementation. For the designer’s Engineer’s Estimate, note that the cost for SWPPP implementation is typically ~3% of a 5-7-acre project’s construction costs. These costs can range from a 2% minimum for smaller projects, to more than 4% for projects >7 acres or located near creeks/ surface waters. These amounts are to be reflected in the Engineer’s Estimate. .

The designer may use the general allowances described below to inform the Engineer’s Estimate for projects that cost up to \$100 million. The Engineer’s Estimate shall be customized, and include the appropriate Bid Items for temporary water pollution control and erosion control on each project, as seen in **Table 5** below:

**Table 5:** General Allowances

| Bid Item   | Unit <sup>3</sup> | Unit Price | Estimated Quantity   | Allowance (TBD) |
|--|-------------------|------------|--|-----------------|
| Prepare ESCAPE or Prepare SWPPP  | LS                |            | 1  |                 |
| Amend ESCAPE or SWPPP  | EA                |            | Annually and As Needed   |                 |
| Risk Level 1, 2, or 3 Inspections in CloudCompli                             | EA                |            | Weekly, and As Needed (before, daily during rain, and after each rain event) |                 |
| Weekly ESCAPE or WPCP Inspections  | EA                |            | Weekly or as directed by VTA/Caltrans permit.                                |                 |
| Risk Level 2 or 3 Ad Hoc Report SMARTS Data entry of pH & turbidity sampling | EA                |            | Daily Per Rain Event   |                 |
| Risk Level 1, 2, or 3 Annual Report  | EA                |            | Annually   |                 |



**Table 5:** General Allowances (cont.)

| Bid Item   | Unit <sup>3</sup> | Unit Price                     | Estimated Quantity | Allowance (TBD) |
|--|-------------------|--------------------------------|--------------------|-----------------|
| Prepare Risk Level 1, 2, or 3 Notice of Termination  | EA                |                                | 1                  |                 |
| <i>Designer to insert all BMPs selected from above section and appropriate unit quantity. See below for estimates.</i> | LF, EA, CY, etc.  |                                | Project Specific   |                 |
| <i>Designer to insert pay items to maintain all BMPs selected from above section with appropriate unit quantity.</i>   | LF, EA, CY, etc.  |                                | Project Specific   |                 |
| <b>Hydroseed</b>   |                   |                                |                    |                 |
| Hydraulic Seed   | Acre              | \$2,400-\$5,200 <sup>2</sup>   | Project Specific   |                 |
| <b>Soil Binder</b>   |                   |                                |                    |                 |
| Plant-Material-Based (Short Lived) Binders   | Acre              | \$900-\$1,200 <sup>1</sup>     | Project Specific   |                 |
| Plant-Material-Based (Long Lived) Binders  | Acre              | \$1,500-\$1,900 <sup>1</sup>   | Project Specific   |                 |
| Polymeric Emulsion Blend Binders   | Acre              | \$900-\$1,900 <sup>1</sup>     | Project Specific   |                 |
| Cementitious-Based Binders   | Acre              | \$1,000-\$1,500 <sup>1</sup>   | Project Specific   |                 |
| <b>Mulch</b>   |                   |                                |                    |                 |
| Standard Hydraulic Mulching (SM)   | Acre              | \$2,100- \$4,700 <sup>2</sup>  | Project Specific   |                 |
| Hydraulic Matrices (HM) & Stabilized   |                   |                                |                    |                 |
| Fiber Matrices   | Acre              | \$2,600-\$5,200 <sup>2</sup>   | Project Specific   |                 |
| Guar-based   |                   | \$3,200-\$7,200 <sup>2</sup>   |                    |                 |
| PAM-based  |                   |                                |                    |                 |
| Bonded Fiber Matrix (BFM)  | Acre              | \$5,000-\$8,800 <sup>2</sup>   | Project Specific   |                 |
| Hydraulic Compost Matrix (HCM)   | Acre              | \$3,800-\$4,500 <sup>2</sup>   | Project Specific   |                 |
| Straw Mulch Crimped or Punched   | Acre              | \$3,150-\$6,900 <sup>1</sup>   | Project Specific   |                 |
| Straw Mulch, with Tackifier  | Acre              | \$2,300-\$6,200 <sup>1</sup>   | Project Specific   |                 |
| <b>Biodegradable Rolled Erosion Control Products</b>   |                   |                                |                    |                 |
| Jute Mesh  | Acre              | \$7,700-\$9,000 <sup>2</sup>   | Project Specific   |                 |
| Curled Wood Fiber  | Acre              | \$10,200-\$13,400 <sup>2</sup> | Project Specific   |                 |



## Footnotes:

1. Source: CASQA Handbook for construction. Individual product manufacturers, solicited by Geosyntec Consultants, provided cost information (2004) and Tetra Tech, Inc. adjusted cost to 2016
2. Source: CASQA Handbook for construction. Individual product manufacturers, solicited by Geosyntec Consultants, provided cost information (2004) and Tetra Tech, Inc. adjusted cost to 2016. Unit price includes install price
3. Units: Lump Sum (LS), Each (EA), Linear Feet (LF), Each (EA), Cubic Yards (CY)



## 4. POST-CONSTRUCTION DESIGN REQUIREMENTS AND MEASURES

Post-construction runoff from projects must be addressed during a project's early design stages when the drainage concepts are first developed. The goal is to reduce runoff and eliminate pollutants from discharging from the site after construction is finished and the site is under normal use.

There are two overarching principles for post-construction stormwater during design. First, avoid runoff where possible by minimizing impervious areas. Then, treat any remaining runoff through site design runoff reduction measures and stormwater treatment measures. Designers should begin site planning early. Site planning design participants should include the facilities maintenance, the design engineer/architect, landscape architect, and the designer of the site stormwater BMPs – often a civil engineer and always a licensed professional. Ideally, the BMP designer should have experience in hydrology and hydraulics. This will facilitate comparison of the BMP options, alternatives, and adjustments to comply with the requirements.



Designers should identify common site elements that can be developed as BMPs for source control, stormwater runoff reduction, or stormwater treatment. To best integrate post-construction BMPs into the design of a project, consider using landscaping as structural BMPs. These may include landscape buffers, seating areas, tree wells, pedestrian plazas and other elements. In most cases, projects will already include landscaping as site features. Designers should note that all landscaping must be native and low-water use, per VTA's Sustainable Landscaping Policy guidelines, included as **Attachment A** to this criteria manual. Additionally, landscaping must not serve as a barrier to natural or security surveillance. For example, landscaping should be designed such that offenders cannot easily hide behind shrubbery.

Lastly, designers should avoid “one-size-fits-all” design concepts. Designers should use caution when applying “standard” or “typical” structural BMP details. Many of these have been developed by cities and counties and may not be effective for all sites or meet the Phase II MS4 permit requirements. Refer to **Attachment J** and **Attachment D2** for typical BMP details, with specific notes for VTA projects.

## 4.1 CAD Standards

The MS4 permit requires that all new stormwater infrastructure be captured in a GIS database. VTA requires designs to be imported from CAD to GIS after design. Thus, certain CAD Standards are required when designing these stormwater features. The standards outlined in the CAD Standards Design Criteria (**Attachment I**), should be followed to ensure uniformity in submittals. If there are discrepancies between the designers contracted or in-scope standards and standards outlined in **Attachment I**, then the Designer should contact the Project Manager, the VTA Environmental MS4 Program Manager, and the VTA GIS Department to determine next actions.



Designers must complete the VTA Signoff for Stormwater and Landscaping Design (Attachment F) for all projects, either exempt or not exempt from post-construction requirements, and submit the form (as well as their CADD drawings) for drainage to be checked along with every major design submittal (i.e., 35%, 65%, 95%, and As-Built Record Documents after construction).

#### 4.2 Small Projects: 2,500 to 5,000 Square Feet of Impervious Surface

VTA is required to implement measures for runoff reduction for all development and redevelopment projects that create and/or replace 2,500 to 5,000 square feet or more of impervious surface (Small Projects). The sections below detail several types of runoff reduction measures.

**Figure 10**, below, shows a newly constructed parking lot that reduced project runoff with vegetated swales and porous pavers. This exemplifies the types of measures that can be installed to reduce runoff.

Project designers are required to use the Stormwater Control Plan (SWCP) Template for Small Projects (Attachment D1) and submit the draft(s) and final SWCPs with every major design submittal (i.e., 35%, 65%, & 95%).

##### 4.2.a Site Design Runoff Reduction Measures

The permit requires the use of one or more of the following site design runoff reduction measures to reduce project runoff:



**Figure 10:** Parking Lot with Runoff Reduction Measures



- **Soil Quality Improvement and Maintenance:** Improvement and maintenance of soil through soil amendments and creation of microbial community;
- **Tree Planting and Preservation:** Planting and preservation of healthy, established trees that include both evergreens and deciduous, as applicable;
- **Porous/ Permeable Pavement:** Pavement that allows runoff to pass through it, thereby reducing the runoff from a site and surrounding areas and filtering pollutants;
- **Self-Retaining Area:** Rooftop and Impervious Area Disconnection - rerouting of rooftop drainage pipes to drain rainwater to rain barrels, cisterns, or permeable areas instead of the storm sewer;
- **Self-Retaining Area:** Vegetated Swales - a vegetated, open-channel management practice designed specifically to treat and attenuate stormwater runoff;
- **Green Roofs:** A vegetative layer grown on a roof (rooftop garden);
- **Rain barrels and cisterns:** Systems that collect and store stormwater runoff from a roof or other impervious surface; and
- **Stream Setbacks and Buffers:** A vegetated area, including trees, shrubs, and herbaceous vegetation, that exists or is established to protect a stream system, lake reservoir, or coastal estuarine area.

Frequently, runoff reduction measures include vegetative improvements, which must comply with VTA's Sustainable Landscaping Policy (**Attachment A**). The sections below give more details for each runoff reduction measure. Designers must specify how to operate and maintain the BMPs selected below by developing an Operation and Maintenance (O&M) Plan, as described in **Section 4.6**. Refer to **Attachment L1** to complete the Template O&M Manual.

#### 4.2.a.1 Soil Quality, Tree Preservation, or Stream Setbacks

These are some of the simplest options, if applicable. Project soils can be amended to increase permeability and promote creation of a beneficial microbial community (see **Figure 11**). Additionally, a designer can adjust plans to preserve healthy and established trees or to create a stream buffer. A stream buffer is a vegetated area that exists or is established to protect a stream system, lake reservoir or coastal estuarine area. Refer to **Attachment J** for typical BMP details.



**Figure 11:** Amended Soils

#### 4.2.a.2 Porous/Permeable Pavement

This option can be easy to install and maintain, cost-effective, and can add aesthetic value to your project. Permeable pavements may include pervious concrete, pervious asphalt, porous pavers, crushed aggregate, open pavers with grass or plantings, open pavers with gravel, or solid pavers. Refer to **Attachment J** for typical BMP details. See **Figure 12**.



**Figure 12:** Pervious pavement in a parking lot.

### 4.2.a.3 Self-Retaining Areas

Another option to reduce runoff from impervious surfaces is to disperse runoff from roofs or pavements to vegetated self-retaining areas. Downspouts can be directed to vegetated areas adjacent to buildings (see **Figure 13**) or extended via pipes to reach vegetated areas further away. Paved areas can be designed with curb cuts, or without curbs, to direct flow into surrounding vegetation. Designers can include vegetated shallow channels that collect and slowly convey runoff to downstream discharge points.

Self-retaining areas must be sized to a maximum 2:1 ratio (impervious:pervious). The entire self-retaining area must be designed to retain an inch of rainfall without flowing off-site. Drains, if any, should be set to allow a maximum of 3" of ponding. Refer to **Attachment J** for typical BMP details.



**Figure 13:** Rooftop and Impervious Area Disconnection

### 4.2.a.4 Green Roofs

Installing a vegetative layer on a roof can reduce the impervious coverage of the project. If the roof infrastructure allows, this helps reduce stormwater runoff. Refer to **Attachment J** for typical BMP details.



#### 4.2.a.5 Rain Barrels & Cisterns

Use of cisterns or rain barrels to comply with this requirement is subject to municipality approval and Planning and Building Permits may be required from other agencies, due to vector concerns. Another option includes underground treatment and storage systems; however, these may have larger footprints or higher construction costs, as well as additional maintenance costs and concerns, and would require close design coordination to implement. Refer to **Attachment J** for typical BMP details.

#### 4.2.b Runoff Reduction Water Balance

The runoff reduction measures implemented in each project must achieve the infiltration, evapotranspiration, and or harvesting/reuse of the 85th percentile, 24-hour storm event. To determine if this runoff reduction has been achieved, designers must complete a Post-Construction Water Balance. To determine the post-construction water balance for the project, use the SMARTS system or use the Office of Water Programs (OWP) online California Phase II Low Impact Development (LID) Sizing Tool- v1.1. To use the SMARTS system, refer to **Attachment G**. To use the OWP LID Sizing Tool refer to **Attachment H**. Additionally, the permit allows the use of an “equivalent” method to quantify runoff reduction. This equivalent can be hydrologic calculations based on an 85<sup>th</sup> percentile storm (the storm frequency that includes 85% of all storm events) and using appropriate site-specific runoff coefficients.

#### 4.3 Regulated Projects: 5,000 Square Feet or more of Impervious Surface

VTA is required to implement measures for design, source control, runoff reduction, and stormwater treatment for all development and redevelopment projects that create and/or replace 5,000 square feet or more of impervious surface (Regulated Projects).



The MS4 permit identifies three categories for Regulated Projects:

1. Projects that increase impervious surfaces by 50% or more of the project site/previously existing development;
  - For these projects, runoff and pollutant\* reduction is required for all impervious surfaces within the project site to the extent technically feasible\*\* from all impervious surfaces.
2. Projects that increase impervious surfaces by less than 50% of the project site/previously existing development; and
  - For these projects, runoff and pollutant reduction is required only from new and/or replaced impervious surfaces.
3. Road Projects creating more than 5,000 square feet of impervious surface.

Project designers are required to use the Stormwater Control Plan (SWCP) Template for Regulated Projects (**Attachment D2**) and submit the draft(s) and final SWCPs with every major design submittal (i.e., 35%, 65%, & 95%).

Footnotes:

\* A pollutant is broadly defined as any agent that may cause or contribute to the degradation of water quality such that a condition of pollution or contamination is created or aggravated.

\*\* Designers must provide sound technical reasons why runoff reduction or stormwater treatment cannot be utilized “to the extent technically feasible” within a site if this requirement is not met (i.e. a drainage study and analysis reflecting consideration of all physical constraints, opportunities and concerns prepared by a qualified professional engineer, etc.). This reasoning should be included in the SWCP submittals to VTA.

### 4.3.a Post-Construction Source Control BMPs

Source Control BMPs are required as a first step for Regulated Projects. Designers must specify what source control BMPs will address reducing runoff (or eliminate pollutants at the source) before Runoff Reduction Measures and Stormwater Treatment may be used for the remaining runoff (these treat the flows after source controls are no longer feasible) in accordance with the Phase II Small MS4 General Permit. Source control BMPs include measures such as routing pollutants to the sanitary sewer system, installing signage that encourage facility users to eliminate non-stormwater discharges from entering the storm drain system (such as the VTA medallion shown in **Figure 14**), designing trash handling area covers, and providing mop sinks for food trucks and vendors (where applicable) to wash out floor mats, etc.

Post Construction source control BMPs fall into broad general categories, including:

- Good Housekeeping
- Preventive Maintenance
- Spill Response (for any pollutant)
- Material Handling and Storage Procedures
- Employee Training
- Waste Handling and Recycling Procedures
- Record Keeping and Reporting
- Erosion Control and Site Stabilization Requirements
- Inspections
- Quality Assurance
- Public Outreach and Education

---

**Figure 14:** VTA “No Dumping” Medallion

---



These categories apply across the VTA for all facilities. Each project must assess the potential sources of pollutants and complete the source control checklists in **Attachment D2**, which outline how the pollutant sources are addressed by the project. For new projects, designers shall assess the pollutants generated during operation of the facility and include BMPs as needed, which may include enclosures or structures to prevent contact of stormwater with pollutants. Designers must specify how to operate and maintain the BMPs selected by developing an Operation and Maintenance (O&M) Plan, as described in **Section 4.6**. Refer to **Attachment O** to complete the Template O&M Manual and for a sample large project O&M Manual.



ELEVATORS AND ESCALATORS: If a VTA facility is large enough to warrant an elevator or escalator(s), a sump pit to collect potential pollutants will be required. Stormwater, especially precipitation, may find its way through the machinery and mix with pollutants generated by the internal mechanisms, and then flow into the sump pit and must be prevented from discharging into the storm drains. Details and specifications on design, sizing, and locations must be determined with collaboration among the designer, Deputy Director of Rail and Facilities, Transit Engineering, and their designee, and be approved by the VTA MS4 Program Manager.

#### 4.3.b Runoff Reduction Measures

Runoff Reduction measures function by storing or detaining runoff so that stormwater constituents settle out or are filtered and trapped by underlying soil or media. Frequently, these measures include vegetative improvements, which must comply with VTA's Sustainable Landscaping Policy (**Attachment A**).

Site Design Runoff Reduction Measures must be incorporated into Regulated Projects' design to reduce the amount of runoff to the extent technically feasible. If designers do not implement runoff reduction measures for the required amount of runoff, the designer must provide details outlining infeasibility in the SWCP (**Attachment D2**). For example, regarding permeable pavement, the Designer should note that the area of pavement installed or weight-loading has no impact on technical feasibility. However, the height of groundwater may impact permeable pavement feasibility.

Refer to **Section 4.2.a** for additional information on the design guidelines for Runoff Reduction Measures. Complete **Attachment E**, outlining Runoff Reduction design and calculation guidelines and refer to **Attachment J** for site design drawings and details. Designers must specify how to operate and maintain the BMPs selected by developing an Operation and Maintenance (O&M) Plan, as described in **Section 4.5**. Refer to **Attachment L1** to complete the Template O&M Manual.





### 4.3.c Stormwater Treatment Measures

After incorporating Site Design Runoff Reduction Measures, remaining runoff from impervious Drainage Management Areas (DMAs) must be directed to a Stormwater Treatment Measure. Stormwater treatment measures capture and treat stormwater by draining the runoff through amended soils, which filter contaminants. Features should promote surface drainage, which is slower and will increase time of concentration and decrease peak flows. Designers should be aware that small changes in building/improvement locations may create spaces to increase BMP effectiveness and decrease the BMP footprint.

Stormwater Treatment Measures include the following:

- Bioretention Facilities
- Flow-Through Planters
- Alternative and Equivalent Bioretention Facilities
- Tree-Box-Type Biofilter/ Tree-Well Filter
- In-Vault Media Filter

See the sections below for an overview of each stormwater treatment measure. Then, complete **Attachment D2**, outlining stormwater treatment design and calculation guideline, and refer to **Attachment J** for design details. Designers must specify how to operate and maintain the BMPs selected by developing an Operation and Maintenance (O&M) Plan, as described in **Section 4.6**. Refer to **Attachment L1** to complete the Template O&M Manual.

#### 4.3.c.1. Bioretention Facilities

This option can help reduce localized flooding, provide biological habitat, and enhance the aesthetics of a project. Bioretention facilities collect stormwater in shallow basins equipped with carefully selected soil media and plants. These features capture stormwater and clean the water by breaking down and filtering pollutants before the water returns to the storm drain system or soaks into the native soils to replenish groundwater.

For bioretention facility landscaping, designers should select species that can withstand the hydrologic regime they will experience. At the bottom of the bioretention facility, plants that tolerate both wet and dry conditions are preferable as this area may be subject to extremely dry, well drained conditions the majority of the time, with occasional ponding after a large storm. The bottom of the facility should accommodate 6-12 inches of ponding, which includes the 3-inch mulch layer. Refer to Attachment J for design standard details and specifications. At the edges, which will remain primarily dry, upland species will be the most resilient. Designers should select plants from appropriate species and must comply with VTA's Sustainable Landscaping Policy (**Attachment A**).

Additionally, VTA approved safety signage should be installed at all applicable bioretention basins, seen in **Figure 15** and in detail in **Attachment K**. The Designer should consult with the Project Manager to determine if safety signage is applicable at each basin.



**Figure 15:** Bioretention Basin with Safety Signage

#### 4.3.c.2 Flow-Through Planter

An above-ground planter box may be appropriate if the development site lacks level landscaped areas for dispersion, and pervious pavements are not practical. Planter boxes can treat runoff from impervious surfaces and may adjust bioretention design parameters if certain special site conditions are met. Special site conditions and adjustments include:



1. Facilities located within 10 feet of structures, or other potential geotechnical hazards established by the geotechnical expert for the project, may incorporate an impervious cutoff wall between the bioretention facility and the structure, or other geotechnical hazard.
2. Facilities in areas with documented high concentrations of pollutants in underlying soil or groundwater, facilities located where infiltration could contribute to a geotechnical hazard, and facilities located on elevated plazas, or other structures, may incorporate an impervious liner and may locate the underdrain discharge at the bottom of the subsurface drainage/storage layer (this configuration is commonly known as a “flow-through planter”).
3. Facilities located in areas of highly infiltrative soils or high groundwater, or where connection of underdrain to a surface drain, or to a subsurface storm drain are infeasible, may omit the underdrain.

#### 4.3.c.3 Bioretention Facility & Flow-Through Planter Sizing Criteria

For Stormwater Treatment Measures, a sizing factor of 4% of the tributary impervious area may be used, or sizing must meet the numeric sizing criteria of the MS4 permit requirements (two volume-based and two flow-based). Designers must meet at least one of the following hydraulic sizing design criteria if the numeric sizing criteria method is chosen:

##### **Volumetric Criteria:**

1. The maximized capture storm water volume for the tributary area, based on historical rainfall records, determined using the formula and volume capture coefficients in Urban Runoff Quality Management, WEF Manual of Practice No. 23/ASCE Manual of Practice No. 87 (1998) pages 175-178 (that is, approximately the 85<sup>th</sup> percentile 24-hour storm runoff event); or



2. The volume of annual runoff required to achieve 80% or more capture, determined in accordance with the methodology in Section 5 of CASQA's Stormwater Best Management Practice Handbook, New Development and Redevelopment, using local rainfall data. Note: Designer should use the most recent version of the CASQA New Development and Redevelopment Handbook.

### Flow-based Criteria:

1. The flow of runoff produced from a rain event equal to at least 0.2 inches per hour intensity; or
2. The flow of runoff produced from a rain event equal to at least 2 times the 85<sup>th</sup> percentile hourly rainfall intensity, as determined from local rainfall records.

Sizing Criteria Worksheets for the numeric sizing criteria method can be found in the Santa Clara Valley Urban Runoff Pollution Prevention Program (SCVURPPP) C.3 Handbook. Volume based solutions require dedication of land for storage of storm water. Flow-based solutions can be integrated into landscaped areas, parking surfaces with permeable material, and other site elements. If the 4% method is chosen, complete the Stormwater Treatment Measure Calculation Worksheets in **Attachment D2** and include them with the SWCP. If the numeric sizing criteria worksheet is used, complete the Sizing Criteria Worksheets in the SVURPPP C.3 Handbook, provide the applicable details for the calculations in **Attachment D2**, and include the C.3 worksheets with the SWCP.

**Figure 16 & Table 6** below are an example design drawing and table showing pre-development and post-development impervious and pervious area calculations, the resulting required treatment area, and the final post-construction treatment area to achieve permit compliance. This exemplifies the sizing criteria.

---

**Figure 16:** Example Drawings with Pre to Post Development Comparison

---

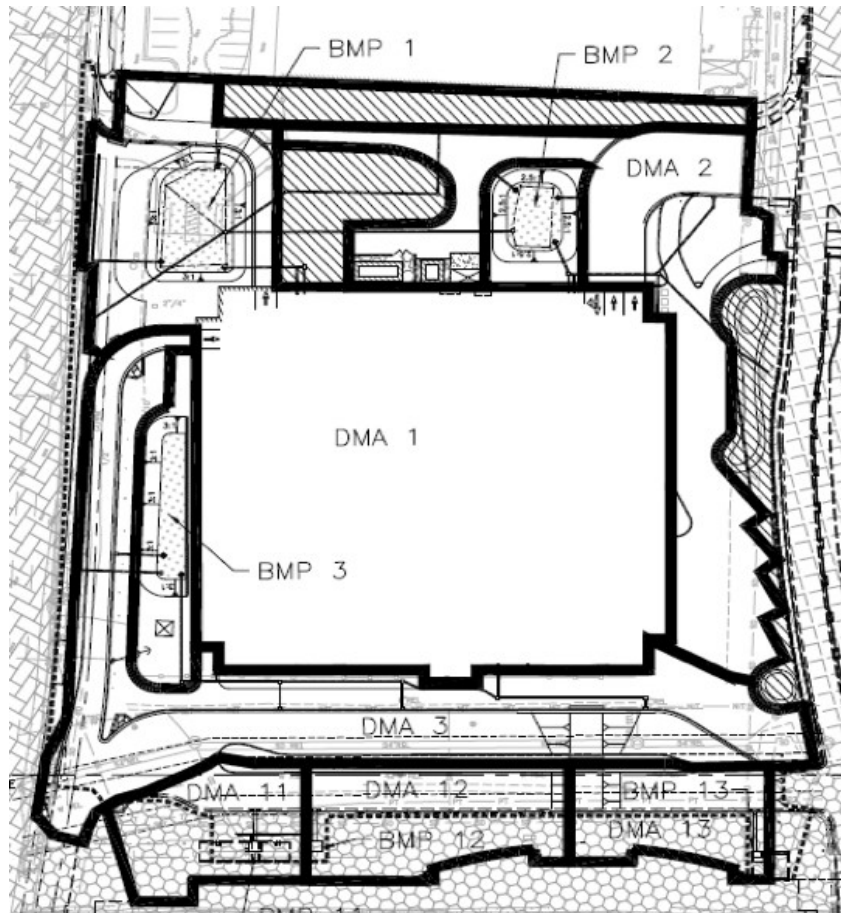

**Table 6:** Pre-development and post-development impervious and pervious area calculations

| DMA ID | PRE-DEVELOPMENT     |                    | POST-DEVELOPMENT    |                    | TREATMENT AREA PROVIDED (SF) | MEETS 4% METHOD |
|--------|---------------------|--------------------|---------------------|--------------------|------------------------------|-----------------|
|        | IMPERVIOUS AEA (SF) | PERVIOUS AREA (SF) | IMPERVIOUS AEA (SF) | PERVIOUS AREA (SF) |                              |                 |
| DMA 1  | 84,913              | -                  | 72,217              | 7,696              | 3,020                        | YES             |
| DMA 2  | 28,345              | -                  | 22,523              | 5,822              | 1,153                        | YES             |
| DMA 3  | 43,351              | -                  | 36,465              | 6,886              | 1,505                        | YES             |

Credit: Aliquot Associates, Inc. Stormwater Facility Operation and Maintenance Plan for VTA BART Silicon

#### 4.3.c.4 Bioretention Facility Alternatives

If designers demonstrate that bioretention facilities or flow-through planters prove to be infeasible, alternatives may be permitted. An alternative design for an equivalent measure may be permitted if the following measures demonstrate equivalent effectiveness to a Bioretention Facility:



- An equal or greater amount of runoff is infiltrated or evapotranspired
- An equal or lower pollutant concentration in runoff that is discharged after bioretention
- An equal or greater protection against shock loadings and spills
- An equal or greater accessibility and ease of inspection and maintenance

A Tree-Box-Type Biofilter/ Tree-Well Filter or In-Vault Media Filter may be used only if it is demonstrated that the use of a bioretention facility or facility of equivalent effectiveness is infeasible. Examples allowed in the permit of infeasible scenarios are as follows:

- Projects creating or replacing an acre or less of impervious area, and located in a designated pedestrian-oriented commercial district (i.e., smart growth projects), and having at least 85% of the entire project site covered by permanent structures
- Facilities receiving runoff solely from existing (pre-project) impervious areas
- Historic sites, structures, or landscapes that cannot alter their original configuration to maintain their historic integrity

The Designer's Stormwater Control Plan (SWCP) must include, as an attachment, a letter from the manufacturer stating the manufacturer has reviewed the Plan, the proposed device meets these technical criteria, and the manufacturer will provide a warranty for two years following activation of the facility.

#### 4.3.d Stormwater Treatment Water Balance

Similar to Small Projects, the Runoff Reduction Measures and Stormwater Treatment Measures implemented in Regulated Projects must achieve the infiltration, evapotranspiration, and or harvesting/ reuse of the 85<sup>th</sup> percentile 24-hour storm event. To determine if the runoff reduction of the 85<sup>th</sup> percentile rainfall event has been achieved,



designers must complete a Post-Construction Water Balance. To determine the post-construction water balance for the project, use the SMARTS system or use the Office of Water Programs (OWP) online California Phase II LID Sizing Tool - v1.1. To use the SMARTS system, refer to **Attachment G**. To use the OWP Low Impact Development (LID) Sizing Tool refer to **Attachment H**. Additionally, the permit allows the use of an “equivalent” method to quantify runoff reduction. This equivalent can be hydrologic calculation based on an 85<sup>th</sup> percentile storm (the storm frequency that includes 85% of all storm events) and using basic runoff coefficients. The following OWP table (**Table 7**) depicts the Typical Saturated Hydraulic Conductivity for most of the soils found at VTA properties.

**Table 7:** Typical Saturated Hydraulic Conductivity of Soil

| Soild Hydrologic Group                           | A           | B           | C          | D          |
|--|-------------|-------------|------------|------------|
| Typical Saturated Hydraulic Conductivity (in/hr) | 1.5         | 1.0         | 0.32       | .003       |
| Saturated Hydraulic Conductivity Range (in/hr)   | 5.67 - 1.42 | 1.42 - 0.57 | .057 -.006 | 0.06 -.001 |

USDA NRCS 2007

| Soil Texture                                     | Sand | Loamy Sand | Sandy Loam | Silt Loam | Loam | Sandy Clay Loam | Clay Loam | Silty Clay Loam | Sandy Clay | Silty Clay | Clay |
|--|------|------------|------------|-----------|------|-----------------|-----------|-----------------|------------|------------|------|
| Typical Saturated Hydraulic Conductivity (in/hr) | 4.74 | 1.18       | 0.43       | 0.26      | 0.13 | 0.06            | 0.04      | 0.04            | 0.02       | 0.02       | 0.01 |

EPA 2010 (p.160)

#### 4.4 Trash Control Requirements

All new construction at VTA must comply with Water Code Section 13383 Order of the Statewide Trash Provisions, as required by the National Pollutant Discharge Elimination System (NPDES) General Permit for Waste Discharge Requirements for Non-Traditional Small Municipal Separate Storm Sewer System Permit for Phase II

communities (Phase II MS4 Permit) in the San Francisco Bay Area (Order 2013-0001-DWQ, NPDES No. CAS000004). Due to this Order, VTA is required to prohibit the discharge of trash 5 mm and greater and is required to address the impacts of trash on surface waters.

#### 4.4.a Trash Full Capture Systems

All VTA projects that have post-construction requirements must install trash control measures. If projects are exempt from post-construction requirements, designers should consult with VTA staff to determine if trash control measures are required. If trash control measures are required, VTA can comply with Water Code Section 13383 by installing trash full capture systems at storm drains, manholes, or outfalls. Trash full capture systems must be certified by the State Water Resources Control Board (SWRCB). The Water Board maintains and updates a Certified Trash Full Capture Systems List of Trash Treatment Control Devices at: [www.waterboards.ca.gov/water\\_issues/programs/stormwater/trash\\_implementation.html](http://www.waterboards.ca.gov/water_issues/programs/stormwater/trash_implementation.html). The Designer should refer to this list when considering trash control devices. See **Figures 17 & 18** for Trash Full Capture Devices.

---

**Figures 17 & 18:** Trash Full Capture Devices

---





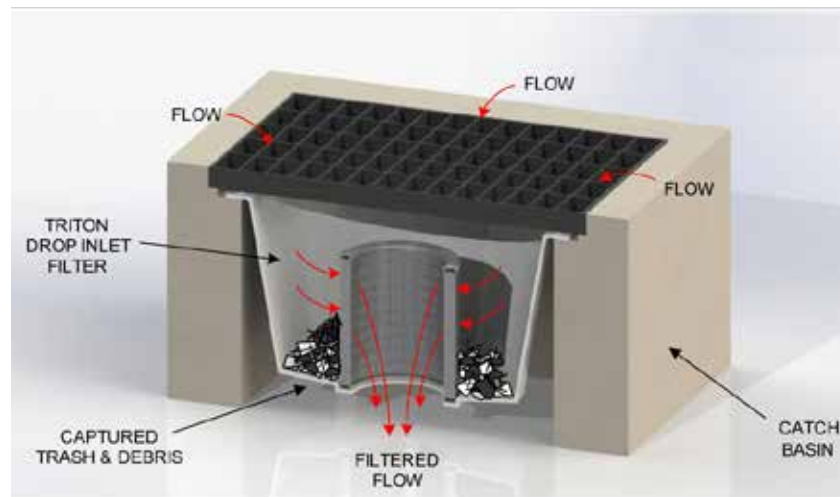

Designer must include the locations of such trash control measures on the project's SWCP Drawings and related CAD Details. The Designer must include language regarding the maintenance of the trash control measures installed in an O&M Manual. Refer to **Attachment L1** for a Template O&M Manual.

#### 4.4.b Multi-Benefit Treatment Systems

Compliance with Water Code Section 13383 can be achieved by installing and maintaining grates at the overflow of all installed stormwater treatment systems, thus providing multiple benefits. These multi-benefit treatment systems must meet numeric sizing criteria for treatment systems and must trap all trash 5 mm or greater to be considered full trash capture equivalent:



**Figure 19:** 5mm Trash Screen on Bioretention Basin



1. Traps all particles that are 5 mm or greater up to the Phase II MS4 Permit design flow or corresponding volume (as seen in **Figure 19** above);
2. Complies with one of the following trash treatment designs applicable to the Multi-Benefit Treatment System:
  - a. Flow-based design that includes:
    - i. A trash treatment capacity equal to or greater than the peak runoff flow collected during the region specific one-year, one-hour storm event from the applicable drainage area, or
    - ii. A trash treatment capacity equal to or greater than the corresponding flow capacity; or
  - b. Volume-based design that includes a trash treatment capacity that is:
    - i. Equal to or greater than the volumetric sizing criteria for treatment systems in the applicable State or Regional Water Board stormwater permit, and
    - ii. Equal to or greater than the volume generated from a one-year, one-hour storm event.

State Water Board recommends using the Rational Equation method to calculate the peak flow rate for runoff from a small subdrainage area that is approximately 50 acres or less. The Rational Equation is shown below:

$$Q = C i A$$

**Q** = design peak runoff rate, cfs;  
**C** = runoff coefficient, dimensionless;  
**i** = rainfall intensity as determined per the rainfall isohyetal map specific to each region, inches/hour and  
**A** = subdrainage area, acres.

State Water Board allows other calculation methods for drainage areas greater than 50 acres to accurately calculate and predict the peak flow rates; provided a registered California Licensed Professional Engineer documents the calculations within the design plans.

- c. Note: A screen is not required if the BMP has capacity to treat either of these flows through media filtration or infiltration into native or amended soils.



3. Incorporates an operation and maintenance plan sufficient to ensure that the captured trash does not migrate from the site; and
4. Is constructed per design plans that are stamped and signed by a registered California licensed professional civil engineer (see Bus. & Prof. Code Section 6700, et seq.).

The Multi-Benefit Treatment Systems listed below are certified by the State Water Board Executive Director. Designer should check the Water Board website to ensure that such systems have not been removed from the approved list.

- Bioretention (See **Attachment J** for a typical Bioretention Facility detail)
- Capture and Use Systems
- Detention Basin
- Infiltration Trench or Basin
- Media Filter

#### 4.5 Operation and Maintenance Manual

Designers must indicate how BMPs will be operated and maintained in an Operation and Maintenance (O&M) Manual. Designers should complete the Template O&M Manual in **Attachment J** and attach it to the project's SWCP. A long-term O&M Plan must be developed prior to project termination to ensure that post-construction stormwater management features are adequately maintained. The O&M Manual should describe the procedures necessary to maintain BMPs for a minimum of 5 years. If BMPs require hydroseed, consider scheduling. Hydroseed application timing should be scheduled with the seasonal rains to allow the seed to germinate before the last charged day of the contract.

## 4.6 Alternative Post Construction Stormwater Management Program

The Designer may propose alternative post-construction measures in lieu of some or all of the Post-Construction requirements outlined in Section F.5.g of the Phase II MS4 Permit for multiple benefit projects. Multiple benefit projects include projects that may address the following, in addition to water quality: water supply, flood control, habitat enhancement, open space preservation, recreation, or climate change. In general, these projects are rare and would require Regional Water Board approval and an opportunity for public comment. See **Figure 20** below for example multiple benefit project elements.



**Figure 20:** Example Multiple Benefit Project Elements

Credit: Example Multi-Benefit Project Elements. Credit: Camden County Municipal Utilities Authority, Stormwater Management and Resource Training Brochure, December 2016. [www.ccmua.org/wp-content/uploads/2016/12/Brochure\\_v6\\_PhotoCover-1.pdf](http://www.ccmua.org/wp-content/uploads/2016/12/Brochure_v6_PhotoCover-1.pdf)

For Projects  
Greater than  
\$100 million

For VTA projects of \$100 million or more and multi-jurisdictional projects, the O&M plan must include surface and subsurface MS4 stormwater treatment facilities so that future maintenance commitments are clearly shown.





Additionally, if stormwater treatment cannot be achieved on-site, the permit allows a facility to mitigate stormwater quality effects on another part of a facility and to combine mitigation requirements from multiple projects into one or more mitigation efforts as a “pavement exchange.” In practice, this means that multiple small projects on a facility can be mitigated with a project on another part of the facility. For example, a bioretention basin created in one part of a facility can be used to mitigate a paving project in another part of the facility. Similarly, new building projects that include landscaping and that exceed their own mitigation requirements can be used for mitigation for other projects.

Although it would require advanced planning by the VTA, this work can be integrated into project planning and master planning. Non-traditional Phase II MS4 permittees are not required to create a campus-wide water quality management plan; however, mitigation must be tracked and recorded to show compliance and effectiveness.

## 5. LANDSCAPING REQUIREMENTS

### 5.1 Planting Guidelines

VTA has developed planting guidelines that apply to all VTA-owned properties in accordance with the VTA Green Building and Sustainable Landscaping Policies (**Attachment A**). The VTA Planting Guidelines (**Attachment B**) includes a list of approved, drought-tolerant tree and understory species, as well as their recommended uses in various typologies frequently encountered on VTA facilities, including Transit Oriented Development (TOD) projects.

Landscape architects and engineers are not required to adhere to these specific plant lists. Rather, the VTA Planting Guidelines provide designers with a framework and expectations that VTA as an agency has for their facilities, to assist designers in selecting location-appropriate low water use and native plants in accordance with VTA policies.

Specific to stormwater treatment facilities, a comparison between the bioretention plant list and the guidance that is provided by the Santa Clara Valley Urban Runoff Pollution Prevention Program (SCVURPPP) is included in Attachment A following the plant guidelines for designers' information and use.

### 5.2 Irrigation Guidelines

To comply with VTA's Green Building and Sustainable Landscaping Policies (**Attachment A**), VTA designs all irrigation systems to conserve water resources at their facilities. VTA has established a Designated Matching Product (DMP) list for certain irrigation products (such as controllers) to ensure that irrigation installed on VTA-owned properties is compatible with VTA's water-use tracking software in use agency-wide.

Please see VTA DMP List (**Attachment C**) to determine the appropriate irrigation products prior to designing landscaping on VTA-owned property.

Note: For Caltrans, TOD, or multi-jurisdictional projects, confer with the VTA Project Manager for the applicable irrigation standards.

## Projects \$100 Million or Greater - Sustainability

For VTA projects with a budget of \$100 million or greater, the project must employ a Sustainability Coordinator to prepare a Sustainability Plan for the project. The Sustainability Plan will include a list and description of green building features to be included in the project and their anticipated environmental and cost savings, including a calculated return on investment. Refer to VTA's Green Building Policy (Attachment A) for specific green building principles.





## 6. RESOURCES AND LINKS

More information can be found at the following:

Santa Clara Valley Urban Runoff Pollution Prevention Program

[www.scvurppp-w2k.com/nd\\_wp.shtml](http://www.scvurppp-w2k.com/nd_wp.shtml)

SCVURPPP C3 Handbook Appendices

[http://www.scvurppp-w2k.com/pdfs/1112/c3\\_handbook\\_appendices-042012-web.pdf](http://www.scvurppp-w2k.com/pdfs/1112/c3_handbook_appendices-042012-web.pdf)

California Stormwater Quality Association

<https://www.casqa.org/>

California State Water Resources Control Board,  
Construction General Permit Page

[https://www.waterboards.ca.gov/water\\_issues/programs/stormwater/constpermits.shtml](https://www.waterboards.ca.gov/water_issues/programs/stormwater/constpermits.shtml)

California State Water Resources Control Board,  
Phase II MS4 Program Page

[www.waterboards.ca.gov/water\\_issues/programs/stormwater/phase\\_ii\\_municipal.shtml](http://www.waterboards.ca.gov/water_issues/programs/stormwater/phase_ii_municipal.shtml)

Bay Area Stormwater Management Agencies Association

<http://basmaa.org/>

Start at the Source: Design Guidance Manual for Stormwater Quality.

<http://www2.oaklandnet.com/government/o/PWA/o/FE/s/ID/OAK026452>

Concrete Promotion Council of Northern California

<https://www.guidestar.org/profile/94-3391273>

California Asphalt Pavement Association

<http://www.calapa.net/>

Interlocking Concrete Pavement Institute

<http://www.icpi.org/>



Porous Pavements, by Bruce K. Ferguson. 2005.  
ISBN 0-8493-2670-2

<https://trove.nla.gov.au/work/14837203?q&versionId=46688020>

USEPA's Managing Wet Weather with Green  
Infrastructure Municipal Handbook Green Streets  
(EPA 833-F-08-009, December 2008)

[https://www.epa.gov/sites/production/files/2015-10/documents/  
gi\\_munichandbook\\_green\\_streets\\_0.pdf](https://www.epa.gov/sites/production/files/2015-10/documents/gi_munichandbook_green_streets_0.pdf)





## 7. ACRONYMS

|                  |  |
|------------------|--|
| <b>BART</b>      | . . . . . Bay Area Rapid Transit                                       |
| <b>BASMAA</b>    | . . . . . Bay Area Stormwater Management Agencies Association          |
| <b>BMP</b>       | . . . . . Best Management Practices                                    |
| <b>CASQA</b>     | . . . . . California Stormwater Quality Association                    |
| <b>CGP</b>       | . . . . . Construction General Permit                                  |
| <b>PED</b>       | . . . . . Planning & Engineering Division                              |
| <b>ESCAPE</b>    | . . . . . Erosion and Sediment Control Action Plan Element             |
| <b>LID</b>       | . . . . . Low Impact Development                                       |
| <b>LUP</b>       | . . . . . Road and linear underground / overhead utility project       |
| <b>MS4</b>       | . . . . . Municipal Separate Storm Sewer Systems                       |
| <b>OWP</b>       | . . . . . Office of Water Programs                                     |
| <b>QSD</b>       | . . . . . Qualified SWPPP Developer                                    |
| <b>QSP</b>       | . . . . . Qualified SWPPP Practitioner                                 |
| <b>SCVURPPP</b>  | . . . . . Santa Clara Valley Urban Runoff Pollution Prevention Program |
| <b>SCVWD</b>     | . . . . . Santa Clara Valley Water District                            |
| <b>SMARTS</b>    | . . . . . Stormwater Multiple Application and Report Tracking System   |
| <b>SPCC Plan</b> | . . . . . Spill Prevention, Control and Counter-Measure Plan           |
| <b>SWCP</b>      | . . . . . Stormwater Control Plan                                      |
| <b>SWMP</b>      | . . . . . Post Construction Storm Water Management Program             |
| <b>SWPPP</b>     | . . . . . Storm Water Pollution Prevention Plan                        |
| <b>TOD</b>       | . . . . . Transit Oriented Development                                 |
| <b>USEPA</b>     | . . . . . U.S. Environmental Protection Agency                         |
| <b>VTA</b>       | . . . . . Santa Clara Valley Transportation Authority                  |



## 8. REFERENCES

- Crowe, Timothy D., and Lawrence J. Fennelly. 2014. Crime Prevention through Environmental Design. 3rd ed., Elsevier.
- Santa Clara Valley Urban Runoff Pollution Prevention Program. 2016. C.3 Stormwater Handbook. Guidance for Implementing Stormwater Requirements for New Development and Redevelopment Projects. Prepared by EOA, June.
- State Water Resources Control Board. 2009. Water Quality Order No. 2009-0009-DWQ as amended by 2010-0014-DWQ & 2012-0006-DWQ. National Pollutant Discharge Elimination System (NPDES). General Permit No. CAS000002. General permit for storm water discharges associated with construction and land disturbance activities. September.
- State Water Resources Control Board. 2013. Water Quality Order No. 2013-0001-DWQ. National Pollutant Discharge Elimination System (NPDES). General Permit No. CAS000004. Waste discharge requirements for storm water discharges from small municipal separate storm sewer systems. February.
- State Water Resources Control Board. 2017. Water code section 13383 order to submit method to comply with statewide trash provisions; requirements for non -traditional small municipal separate storm sewer system (MS4) permittees.

## 9. ACKNOWLEDGMENTS

**By:**

Rachael Keish, PE & QSD/P

**Contributions by:**

Paul Landon, QSP

Hayden Kessenich, ENV SP

Alan Schroder, CAD Manager

Selena Gonzalez, QSP



**With Special Thanks:**

Sally Reynolds, RELM

Scott Baker, RELM

**Technical Support:**

Leon Kouyoumjian, Grid - Strategy + Design, LLC



**ATTACHMENT A:  
APPLICABLE VTA POLICIES**



## A1: VTA SUSTAINABLE LANDSCAPING POLICY



DocuSign Envelope ID: B133B052-9FF2-47D9-A645-50628727410E

|   |                         |            |
|---|-------------------------|------------|
| <b>POLICY</b><br><br><b>Sustainable Landscaping</b> | <b>Document Number:</b> | 340.003    |
|   | <b>Version Number:</b>  | 2          |
|   | <b>Date:</b>            | 09/26/2018 |

**1. Purpose:**

The purpose of this policy is to conserve water resources, reduce or prevent pollution, and improve wildlife habitat and biodiversity through the use of sustainable landscaping practices.

**2. Scope:**

This policy applies to the planning, design, construction, and maintenance of landscaping for all VTA capital projects and for all VTA facilities located on VTA-owned property.

**3. Responsibilities:**

This policy applies to all VTA employees and contractors responsible for planning, designing, constructing, and maintaining landscaping for VTA projects and facilities.

**4. Policy:**

VTA commits to implement the following sustainable landscaping practices to the maximum extent possible in accordance with the purpose of this policy.

4.1 Conserve Water Resources

- Plant low maintenance, drought tolerant, and native plant species;
- Refer to the Santa Clara Valley Water District’s *Approved Plant List*, which identifies water needs for plants using Water Use Classifications of Landscape Species in Region #1 for the North Central Coast of California, and/or the East Bay Municipal Utility District’s *Landscapes for Summer-Dry Climates of the San Francisco Bay Region* for low water use plants;
- Preserve and protect established vegetation;
- Incorporate compost, mulch, and other appropriate organic materials to reduce runoff, conserve soil moisture, and increase carbon sequestration;
- Limit or eliminate the use of turf area by using plantings, mulch, decomposed granite, rock, or pervious hardscape;
- Group plants with similar water needs into climate and water zones (“hydrozones”) to maximize water efficiency;
- Choose irrigation equipment that uses the least amount of water for the design, layout, and type of landscape;



|                               |                                |             |
|-------------------------------|--------------------------------|-------------|
| <b>Original Date:</b> 4/24/14 | <b>Revision Date:</b> 09/26/18 | Page 1 of 4 |
|-------------------------------|--------------------------------|-------------|



DocuSign Envelope ID: B133B052-9FF2-47D9-A645-50628727410E

|   |                         |            |
|---|-------------------------|------------|
| <b>POLICY</b><br><br><b>Sustainable Landscaping</b> | <b>Document Number:</b> | 340.003    |
|   | <b>Version Number:</b>  | 2          |
|   | <b>Date:</b>            | 09/26/2018 |

- Install rain shut-off devices, flow sensors, weather-based irrigation controllers, pressure compensating spray heads, and vandal resistant sprinkler heads and adjust irrigation times and durations with the seasons and for proper coverage and even distribution;
- Use reclaimed water for irrigation where available;
- Respond promptly to leaks and perform regular inspections of irrigation equipment to ensure good working order;
- In areas of heavy public use, select and place landscaping and irrigation equipment appropriately to avoid damage and follow city specifications for irrigation equipment placement.

4.2 Reduce or Prevent Pollution

- Refer to the Santa Clara Valley Urban Runoff Pollution Prevention Program’s *Plant List and Planting Guidance for Landscape-Based Stormwater Measures*, C.3 Stormwater Handbook, Appendix D, for guidance in selecting plants and designing landscape to reduce or prevent pollution;
- Ensure that projects are designed to minimize the use of non-organic herbicides, pesticides, and fertilizers;
- Limit or avoid the use of non-organic chemicals to control weeds and pests at existing facilities;
- Avoid use of overhead spray irrigation adjacent to storm drain inlets and pedestrian walkways to prevent water from directly discharging to the Municipal Separate Storm Sewer Systems (MS4) and misting into public paths;
- Use vegetation, mulching, low impact development treatment, and other green infrastructure elements to reduce runoff and treat storm water runoff from facilities and hardscape;
- Use VTA’s *Storm Water and Landscaping Design Criteria Manual* as guidance to control storm water runoff on all VTA properties and project sites in compliance with the requirements of the Phase II Small MS4 General Permit Program.

4.3 Improve Wildlife Habitat and Biodiversity

- Select plants native to California that provide habitat and food for birds, insects, and other wildlife;



|                               |                                |             |
|-------------------------------|--------------------------------|-------------|
| <b>Original Date:</b> 4/24/14 | <b>Revision Date:</b> 09/26/18 | Page 2 of 4 |
|-------------------------------|--------------------------------|-------------|



DocuSign Envelope ID: B133B052-9FF2-47D9-A645-50628727410E

|   |                         |            |
|---|-------------------------|------------|
| <b>POLICY</b><br><br><b>Sustainable Landscaping</b> | <b>Document Number:</b> | 340.003    |
|   | <b>Version Number:</b>  | 2          |
|   | <b>Date:</b>            | 09/26/2018 |

- Under no circumstances shall any plants listed as invasive by the California Invasive Plant Council’s Invasive Plant Inventory be used for landscaping.

**5. Definitions:**

- 5.1 **Sustainable landscaping** refers to the use of design and maintenance practices that work harmoniously with local climate and soils. A sustainable landscape is adapted to an area’s rainfall patterns and can thrive with minimal watering, maintenance, and chemical use. In contrast, conventional landscapes may feature plants that require lots of water, frequent gas-powered mowing to maintain, and pesticides and fertilizers to promote healthy growth. Rain or excess irrigation water can transport these chemicals into storm drains and are harmful to fish and other wildlife.
- 5.2 **Invasive plant** means species of plants identified by the California Invasive Plant Council (IPC) as invasive to areas within the IPC-delineated Central West region, and that are rated by the IPC as being either moderately invasive or highly invasive. It also includes plants in the United States Department of Agriculture invasive and noxious weeds database.
- 5.3 **Native plant** means a plant indigenous to a specific area of consideration. For the purpose of this Policy, the term shall refer to plants indigenous to the coastal ranges of Central and Northern California, and more specifically to such plants that are suited to the ecology of the present or historic natural community of the project’s vicinity.

**6. Summary of Changes:**

The Purpose was revised to increase clarity of the three main objectives of the policy. Responsibilities were moved to the Policy section and grouped into the objectives referred to in the Purpose. The Scope was revised to increase clarity for the reader. Terminology, definitions, and references were updated throughout the document to be consistent and current given the passage of time since the initial release of the policy. Approval Information was updated as needed.



|                               |                                |             |
|-------------------------------|--------------------------------|-------------|
| <b>Original Date:</b> 4/24/14 | <b>Revision Date:</b> 09/26/18 | Page 3 of 4 |
|-------------------------------|--------------------------------|-------------|





DocuSign Envelope ID: B133B052-9FF2-47D9-A645-50628727410E

|   |                         |            |
|---|-------------------------|------------|
| <b>POLICY</b><br><br><b>Sustainable Landscaping</b> | <b>Document Number:</b> | 340.003    |
|   | <b>Version Number:</b>  | 2          |
|   | <b>Date:</b>            | 09/26/2018 |

**7. Approval Information:**

| <i>Prepared by</i>   | <i>Reviewed by</i>  | <i>Approved by</i>   |
|--|---|--|
| <p>DocuSigned by:<br/><i>Ann Calnan</i><br/>608D81DCEB374B9...</p> <p>Ann Calnan<br/>Manager, Environmental Programs</p> | <p>DocuSigned by:<br/><i>Carolyn M Gonot</i><br/>D2267F28DC0541F...</p> <p>Carolyn Gonot<br/>Chief Engineering and Program Delivery Officer</p> | <p>DocuSigned by:<br/><i>Nuria I. Fernández</i><br/>8171B5A864514F3...</p> <p>Nuria I. Fernández<br/>General Manager/CEO</p> |

9/28/2018

Date Approved: \_\_\_\_\_



|                               |                                |             |
|-------------------------------|--------------------------------|-------------|
| <b>Original Date:</b> 4/24/14 | <b>Revision Date:</b> 09/26/18 | Page 4 of 4 |
|-------------------------------|--------------------------------|-------------|



## A2: VTA GREEN BUILDING POLICY



6.9.a

|  |                  |            |
|--|------------------|------------|
| <b>POLICY</b><br><br><b>Green Building</b> | Document Number: | 400.004    |
|  | Version Number:  | 01         |
|  | Date:            | 08/07/2018 |

*1. Purpose*

The Green Building Policy establishes a comprehensive framework for VTA to incorporate green building principles into its projects with the intention of designing, operating, and maintaining projects that are environmentally, socially, and economically sustainable.

Background

In 2008, VTA approved the Sustainability Program and established a goal to incorporate green building principles into VTA projects. VTA has since constructed and renovated several facilities with renewable energy, water and energy efficient fixtures, and other green building features. With this Green Building Policy, VTA seeks to formally incorporate green building principles into its projects. The intent of these principles is to conserve natural resources, reduce waste, support the local economy, provide healthy indoor environments, and generate long-term cost savings for VTA. Cost savings of green buildings is achieved primarily through reduced energy costs because green buildings are, on average, 30% more energy efficient when compared to conventional buildings.

These green building principles are supported by the vision and values of the 2016 Strategic Plan to innovate the way Silicon Valley moves. By proactively creating, collaborating, and leading in green building efforts, VTA will continue to advance its environmental sustainability goals.

*2. Scope*

For the purposes of this policy, green building refers to the practice of creating structures and using processes that are environmentally responsible and resource-efficient throughout a building's life-cycle from siting to design, construction, operation, maintenance, renovation, and de-construction.

This policy applies to the planning, design, construction, renovation, and operation of all capital, facility, and joint-development projects on VTA-owned property.

*3. Responsibilities*

All VTA employees shall be directed to incorporate green building principles into all capital, facility, and joint-development projects on VTA-owned property to the maximum extent possible.

VTA Executive Staff shall ensure that this policy is applied early on in the planning, design, construction, renovation, and operation of VTA projects.

The Environmental Programs Department and VTA Sustainability Program Team shall provide assistance to VTA employees to meet the requirements of this policy and support the implementation and maintenance of this policy.



|                              |                    |             |
|------------------------------|--------------------|-------------|
| Original Date:<br>08/01/2018 | Revision Date: N/A | Page 1 of 4 |
|------------------------------|--------------------|-------------|



6.9.a

|  |                  |            |
|--|------------------|------------|
| <b>POLICY</b><br><b>Green Building</b> | Document Number: | 400.004    |
|  | Version Number:  | 01         |
|  | Date:            | 08/07/2018 |

The Real Estate and Joint Development Department shall encourage private developers to incorporate green building principles into projects located on VTA-owned property to the maximum extent possible.

**4. Policy**

Included in this policy is a list of green building principles established by the State of California, U.S. Green Building Council (USGBC), U.S. Environmental Protection Agency (EPA), and Institute for Sustainable Infrastructure.

VTA shall commit to incorporating the principles listed below into the planning, design, construction, renovation, and operation of all new and existing facilities. This effort shall be done to the maximum extent possible for all facilities that are constructed, owned, or managed by VTA or on VTA-owned property. Generally, the earlier green building features are incorporated into the design process, the lower the cost. Therefore, this effort shall be done at the earliest stage possible in the design process.

In addition, for VTA projects with a budget of \$100 million or greater, a Sustainability Plan shall be prepared that designates a Sustainability Coordinator for the project. The Sustainability Plan shall include a list and description of green building features to be included in the project and their anticipated environmental and cost savings, including a calculated return on investment.

**4.1 California Green Building Standards Code**

California Green Building Standards Code, California Code of Regulations (CCR), Title 24, Part 11, also known as CALGreen, applies to the planning, design, operation, construction, use and occupancy of every newly constructed building or structure, unless otherwise indicated in the Code, throughout the State of California.

VTA commits to the following:

- Meet all mandatory measures for nonresidential structures. These mandatory measures are provided in Chapter 5 of the CALGreen Code.
- Incorporate as many voluntary measures for nonresidential structures as possible, with the goal of achieving Tier 1 and/or Tier 2 voluntary compliance. Voluntary measures are provided in Appendix A5 of the CALGreen Code.
- Provide electric vehicle charging stations for zero emission vehicles that are compatible with VTA’s existing electric vehicle charging network based on the recommended ratios in Tier I of the CALGreen Code and as practicable.
- Exceed CALGreen requirements for the diversion of construction debris and waste from landfills.



|                              |                    |             |
|------------------------------|--------------------|-------------|
| Original Date:<br>08/01/2018 | Revision Date: N/A | Page 2 of 4 |
|------------------------------|--------------------|-------------|



6.9.a

|  |                         |            |
|--|-------------------------|------------|
| <b>POLICY</b><br><b>Green Building</b> | <b>Document Number:</b> | 400.004    |
|  | <b>Version Number:</b>  | 01         |
|  | <b>Date:</b>            | 08/07/2018 |

- Consider opportunities to incorporate CALGreen mandatory and voluntary measures for residential structures where applicable to VTA joint development projects.

4.2 Other Green Building Principles

VTA commits to incorporate other green building principles and programs, as applicable. Specifically, VTA commits to the following:

- Ensure that projects meet the highest standards for energy efficiency by referring to the USGBC’s Leadership in Energy and Environmental Design (LEED) program, Institute for Sustainable Infrastructure’s Envision™ rating system, EPA’s Energy Star program, California Energy Commission’s (CEC) Building Energy Efficiency Standards, and Pacific Gas and Electric’s (PG&E) Business Energy Checkup website.
- Incorporate on-site renewable energy systems (e.g. solar photovoltaic arrays and solar hot water) or carbon-free electricity (power generated without fossil fuels) to the maximum extent practicable, provided the systems are economically feasible.
- Ensure that projects are designed to minimize water use for both indoor and outdoor uses and utilize fixtures and equipment that meet the EPA’s Water Sense ratings.
- Ensure that projects are designed to minimize the use of non-organic herbicides, pesticides, and fertilizers.
- Include on-site recycling and compost programs for organic waste.
- Consider opportunities for on-site water reuse or recycling.
- Connect to recycled water infrastructure (purple pipes) for irrigation or process water whenever available.
- Comply with LEED indoor air quality standards for air filtration, ventilation, and selection of building materials to support the health and well-being of building occupants.
- Include requirements for quantifying the disposition of construction debris and waste in contract specifications.
- Comply with all applicable VTA policies, including VTA’s Sustainable Landscaping Policy and Complete Streets Policy.
- Comply with VTA’s Municipal Separate Storm Sewer System (MS4) Permit.
- Use vegetation, soil, and other green infrastructure elements to reduce and treat storm water at its source.



|                                     |                           |                    |
|-------------------------------------|---------------------------|--------------------|
| <b>Original Date:</b><br>08/01/2018 | <b>Revision Date:</b> N/A | <b>Page 3 of 4</b> |
|-------------------------------------|---------------------------|--------------------|



6.9.a

|  |                         |            |
|--|-------------------------|------------|
| <b>POLICY</b><br><br><b>Green Building</b> | <b>Document Number:</b> | 400.004    |
|  | <b>Version Number:</b>  | 01         |
|  | <b>Date:</b>            | 08/07/2018 |



- Require outside developers to consider Zero Net Energy (ZNE) building practices for new residential and commercial construction, and include such guidance in VTA proposal criteria (weighted such that proposals that make stronger commitments to ZNE measures are considered more favorably).

**5. Definitions**

The following terms shall have the assigned definitions for all purposes under this policy:

- 5.1. **CALGreen** refers to the California Green Building Standards Code, California Code of Regulations (CCR), Title 24, Part 11, available at the California Building Standards Commission website at [www.bsc.ca.gov](http://www.bsc.ca.gov).
- 5.2. **Green building** refers to the practice of creating structures and using processes that are environmentally responsible and resource-efficient throughout a building's life-cycle from siting to design, construction, operation, maintenance, renovation, and deconstruction. Green building is also known as a sustainable or high performance building.
- 5.3. **Green infrastructure** refers to bioswales, bioretention basins, permeable pavement, and other systems that use or mimic natural processes to filter, treat, or reuse storm water on site. Green infrastructure is referred to as low impact development when applied to land.
- 5.4. **Zero Net Energy** refers to a building with zero net energy consumption, meaning the total amount of energy used by the building on an annual basis is roughly equal to the amount of renewable energy created on the site. Goals for the development of zero net energy buildings are included in the California Energy Efficiency Strategic Plan.

**Approval Information**

| <i>Prepared by</i>  | <i>Reviewed by</i>  | <i>Approved by</i>  |
|---|---|---|
| <br>Carolyn Gonot<br>Chief Engineering and Program<br>Delivery Officer | <br>Nuria I. Fernández<br>General Manager/CEO | <br>VTA Board of Directors |

Date Approved: 10/4/18



|                                     |                           |                    |
|-------------------------------------|---------------------------|--------------------|
| <b>Original Date:</b><br>08/01/2018 | <b>Revision Date:</b> N/A | <b>Page 4 of 4</b> |
|-------------------------------------|---------------------------|--------------------|



## A3: VTA COMPLETE STREETS POLICY



|   |                         |           |
|---|-------------------------|-----------|
| <p><b>COMPLETE STREETS</b></p> <div style="border: 1px solid black; padding: 5px; width: fit-content; margin: 10px auto;">Exhibit A</div> | <b>POLICY</b>           |           |
|   | <b>Document Number:</b> | PP-PL-001 |
|   | <b>Version Number:</b>  | 01        |

**1. Purpose**

This policy sets forth responsibilities, guiding principles, and practices that VTA will follow to ensure that Complete Streets best practices are used during the planning, design, funding, and construction of all transportation capital projects and funding programs administered by VTA.

The Complete Streets concept calls for public roads to be designed and built for the safe mobility of all roadway users. Motorists, transit riders, bicyclists, and pedestrians of all ages and abilities must be able to move safely along and across the transportation network.

More specifically, Complete Streets are streets:

- That are planned, designed, funded, constructed, operated, and maintained for the safe travel of all users.
- Where designs are context sensitive, and incorporate a balanced network approach.
- That prioritize the safety, comfort, and convenience of pedestrians, bicyclists, and transit riders (including access and operations) of all ages and abilities, as appropriate for the local context, while still providing safe accommodations for motorists and other roadway users.
- Where completed capital projects should improve—and at a minimum must not degrade—the safety, comfort, and convenience of pedestrians, bicyclists, or transit customers of all ages and abilities, including travel time of transit operations (recognizing that there may be situations where one of these modes may need to be prioritized over another).
- Where designs are developed with input from the community and support future conditions.

**2. Scope**

This policy applies to all relevant VTA Divisions and to VTA employees, contractors, and consultants performing work for VTA. It applies to transportation capital projects and capital project funding programs administered by VTA.

**3. Responsibilities**

**Complete Streets In All Divisions** – VTA Divisions will incorporate Complete Streets principles and practices into all phases of their transportation capital projects and funding programs.

**Revising Policies, Procedures, and Plans** – VTA Divisions will undertake updating existing policies, procedures, specifications, plans, templates, and design manuals to incorporate Complete Streets principles and practices.



|                       |                       |             |
|-----------------------|-----------------------|-------------|
| <b>Original Date:</b> | <b>Revision Date:</b> | Page 1 of 5 |
| 12/01/2017            | N/A                   |             |





|                         |                         |           |
|-------------------------|-------------------------|-----------|
| <b>COMPLETE STREETS</b> | <b>POLICY</b>           |           |
|                         | <b>Document Number:</b> | PP-PL-001 |
|                         | <b>Version Number:</b>  | 01        |

|           |
|-----------|
| Exhibit A |
|-----------|

**Transportation Funding** – Funding programs administered by VTA, including 2016 Measure B, will support Complete Streets principles and practices.

4. Policy

A. **Complete Streets Principles and Practices** – VTA will apply the following Complete Streets principles and practices to all transportation capital projects and funding programs:

- **Serve All Users** – All transportation improvements must be planned, designed, constructed, operated and maintained to support safe and convenient access for all users, and increase mobility for walking, bicycling and transit use.
- **Use Context Sensitive Design** – VTA staff should design transportation projects to be appropriate for the surrounding land use, community character, and function of the transportation facility. Designs should reflect desired or anticipated future conditions.
- **Maintain or Enhance Networks** – With every transportation project, VTA staff should seek opportunities to create, maintain or enhance network connectivity for all users, and ensure that the user experience is maintained across jurisdictional boundaries. The transportation network for pedestrians, bicyclists, and transit riders should not be severed or degraded with the completion of new or modified transportation infrastructure.
- **Incorporate Technology** – VTA staff should incorporate technology to improve safety and operations of the roadway system for all users, and to improve information dissemination.
- **Be Consistent with Adopted Plans** – VTA staff should assure consistency with regional, local and VTA planning documents, including the *Countywide Bicycle Plan*, *Pedestrian Access to Transit Plan*, *Transit Passenger Environment Plan*, VTA’s corridor studies, Metropolitan Transportation Commission’s *Regional Transportation Plan*, and Member Agency planning documents.
- **Maintain Transportation Infrastructure** – With every transportation project, VTA staff should seek opportunities to maintain, upgrade, or replace transportation infrastructure and technology, using asset management best practices.
- **Seek and Respond to Public Input** – VTA staff should seek community input on transportation projects and programs early in the planning and design stages. Input should be sought from relevant VTA Advisory Committees, local communities, and other stakeholders.
- **Build Complete Streets Infrastructure** – VTA staff should proactively seek opportunities to integrate Complete Streets infrastructure into every transportation project.



|                       |                       |             |
|-----------------------|-----------------------|-------------|
| <b>Original Date:</b> | <b>Revision Date:</b> | Page 2 of 5 |
| 12/01/2017            | N/A                   |             |



|  |                         |           |
|--|-------------------------|-----------|
| <b>COMPLETE STREETS</b><br><br>Exhibit A | <b>POLICY</b>           |           |
|  | <b>Document Number:</b> | PP-PL-001 |
|  | <b>Version Number:</b>  | 01        |

- **Design Using Latest and Best Practice Design Standards and Guides** – VTA staff should: (i) use latest and best practice multi-modal design standards and guides when developing and delivering capital projects; (ii) consult innovative pedestrian, bicycle, and transit design manuals; and (iii) seek new examples as innovations are tested. Examples of national, state, and local design standards/guidelines that support Complete Streets include:

National

- American Association of State Highway and Transportation Officials (AASHTO) *Policy on Geometric Design of Highways and Streets*
- AASHTO *Guide for the Planning, Design, and Operation of Pedestrian Facilities*
- AASHTO *Guide for the Development of Bicycle Facilities*
- Institute of Transportation Engineers (ITE) *Designing Walkable Urban Thoroughfares*
- ITE *Recommended Design Guidelines to Accommodate Pedestrians and Bicycles at Interchanges*
- National Association of City Transportation Officials (NACTO) *Urban Bikeway Design Guide*
- NACTO *Urban Street Design Guide*
- NACTO *Transit Street Design Guide*
- NACTO *Urban Street Stormwater Guide*

Regulatory

- United States Department of Justice *ADA Standards for Accessible Design*
- U.S. Access Board *Proposed Guidelines for Pedestrian Facilities in the Public Right-of-Way*

State

- *California Highway Design Manual* and all Deputy Directives and Design Information Bulletins
- *California Manual on Uniform Traffic Control Devices* and adopted Interim Approvals
- *Main Street, California – A Guide for Improving Community and Transportation Vitality*
- Caltrans *Class IV Bikeway Guidance (Separated Bikeways/Cycle Tracks)*, DIB 89

Local

- VTA *Community Design and Transportation Manual of Best Practices for Integrating Transportation and Land Use*
- VTA *Bicycle Technical Guidelines*
- VTA *Pedestrian Technical Guidelines*
- VTA *Multi-Modal Design Practices and Principles*
- Santa Clara Valley Urban Runoff Pollution Prevention Program *C.3 Stormwater Handbook*



|                       |                       |             |
|-----------------------|-----------------------|-------------|
| <b>Original Date:</b> | <b>Revision Date:</b> | Page 3 of 5 |
| 12/01/2017            | N/A                   |             |



|                         |                         |           |
|-------------------------|-------------------------|-----------|
| <b>COMPLETE STREETS</b> | <b>POLICY</b>           |           |
|                         | <b>Document Number:</b> | PP-PL-001 |
|                         | <b>Version Number:</b>  | 01        |

**B. Exceptions to Policy** Pedestrian, bicycle, and transit infrastructure and information technology systems identified in local, regional, or countywide planning documents should be incorporated into transportation capital projects administered by VTA if they fall within the project limits. However, exceptions will be considered by the division head of the relevant Division where exceptional circumstances prohibit adherence to this policy. Infrastructure or technology that is identified in a local, regional, or county planning document may be excluded from a transportation project in any of the following circumstances:

- The cost of providing the Complete Streets element is disproportionate to the overall cost of the project, as set forth in the Federal Highway Administration [Accommodating Bicycle and Pedestrian Travel](#), which notes an advisory threshold of 20% of overall cost of project.
- A roadway user is legally prohibited from using the transportation facility.
- There is an absence of existing and future need, based on the existing and planned transportation network and land use context of the area.
- The Complete Streets element would result in specific, documented detrimental environmental or social impacts that outweigh the need for the infrastructure or technology.

The proposed exception, as well as supporting data and documentation, must be approved in writing by the division head of the VTA Division that is overseeing the project and made publicly available.

**C. Evaluation** – VTA will evaluate, monitor and report on the effectiveness of its projects using appropriate and practical performance metrics that may be tracked over time. Exceptions will be documented on a case-by-case basis in situations where evaluating and monitoring projects are infeasible or impractical.

**D. Capital Projects Funded by VTA** – VTA expects that Member Agencies will follow their Complete Streets policies or resolutions when delivering capital projects that have received funding through VTA. If a Member Agency has not adopted a Complete Streets policy or resolution, VTA will encourage the Member Agency to follow the Complete Streets practices described in section 4A and 4B. VTA will ensure that capital projects funded through 2016 Measure B meet the measure’s Complete Streets reporting requirements adopted by the VTA Board of Directors.

**E. Member Agency Complete Streets Responsibilities** – This policy does not absolve any Member Agency of its responsibility to fund, design, build, operate or maintain Complete Streets elements on transportation facilities under that agency’s control.



|                       |                       |             |
|-----------------------|-----------------------|-------------|
| <b>Original Date:</b> | <b>Revision Date:</b> | Page 4 of 5 |
| 12/01/2017            | N/A                   |             |



|                         |                  |           |
|-------------------------|------------------|-----------|
| <b>COMPLETE STREETS</b> | <b>POLICY</b>    |           |
|                         | Document Number: | PP-PL-001 |
|                         | Version Number:  | 01        |

**F. Funding Complete Streets Elements** – VTA staff will seek to fund Complete Streets elements through a variety of sources, including, but not limited to: integration into a larger transportation project, Member Agency contributions, and outside grant funding.

**5. Definitions**

*All Users*—Includes pedestrians, bicyclists, transit riders, transit vehicles, motorists, commercial vehicles, emergency vehicles, and users of wheelchairs and other mobility devices.

*Complete Streets*—See definition in Section 1.

*Transportation infrastructure*—Infrastructure that serves transportation purposes, including, but not limited to streets, highways, Express Lanes, interchanges, transit stops and stations, rail lines, sidewalks, bike lanes, paved paths, bicycle/pedestrian bridges or undercrossings, signals, Intelligent Transportation Systems (ITS) infrastructure, bike parking.

*Transportation project*—A planning effort or capital project that addresses transportation infrastructure.

*Transportation program*—A program that funds transportation planning efforts or capital projects.

*Intelligent Transportation Systems (ITS)*—Technologies applied to transportation systems and vehicles to improve their safety and performance. Examples include: transit signal priority, synchronized traffic signals, warning systems installed on individual vehicles, bicycle, pedestrian, or vehicle detection systems, real-time transit information, incident warnings.

*Member Agency*—the fifteen towns and cities within Santa Clara County and the County of Santa Clara.

**6. Summary of Changes**

**7. Approval Information**

| <i>Prepared by</i>                                    | <i>Reviewed by</i>   | <i>Approved by</i>                            |
|---|--|---|
| <br>Lauren Ledbetter<br>Senior Transportation Planner | <br>Chris Augenstein<br>Director of Planning and<br>Programming Division | <br>Nuria I. Fernandez<br>General Manager/CEO |

Date Approved: January 11, 2018



|                |                |             |
|----------------|----------------|-------------|
| Original Date: | Revision Date: | Page 5 of 5 |
| 12/01/2017     | N/A            |             |



Date: November 17, 2017  
Current Meeting: December 7, 2017  
Board Meeting: December 7, 2017

**BOARD MEMORANDUM**

**TO:** Santa Clara Valley Transportation Authority  
Board of Directors  
**THROUGH:** General Manager, Nuria I. Fernandez  
**FROM:** Director - Planning & Programming, Chris Augenstein  
**SUBJECT:** VTA Complete Streets Resolution and Policy

APPROVED ACCEPTED ADOPTED AMENDED DEFERRED REVIEWED  
Santa Clara Valley Transportation Authority  
Board of Directors  
Blaine F. Balboa, Board Secretary  
BY: [Signature]  
DATE: 12/7/17

Policy-Related Action: Yes Government Code Section 84308 Applies: No

**ACTION ITEM**

**RECOMMENDATION:**

Adopt a resolution establishing a Complete Streets Policy for VTA.

**BACKGROUND:**

Complete Streets are generally defined as streets that are planned, designed, funded, constructed, operated, and maintained for the safe travel of all users, of all ages and abilities. They are streets where designs are context sensitive, which incorporate a balanced network approach, and which prioritize the safety, comfort, and convenience of pedestrians, bicyclists, and transit riders of all ages and abilities, as appropriate for the local context, while still providing safe accommodations for motorists and other roadway users.

VTA has long promoted Complete Streets. Beginning in 2002, the VTA Board of Directors established the Community Design & Transportation program, which promoted multimodal streets and context sensitive design. In 2009, the VTA Board of Directors adopted a policy, *Multimodal Design Practices and Principles*, which directed staff to model all future roadway improvements based on the multimodal design used for the reconstructed U.S. 101/ Tully Road interchange. More recently, the 2016 Measure B transportation sales tax passed by Santa Clara County voters in November 2016 requires that Local Streets and Roads projects be delivered using Complete Streets best practices.

VTA has been delivering Complete Streets through various projects and programs, but has done

so without an overarching policy. The proposed Complete Streets policy formalizes the practices VTA is already following. It also strengthens the Authority's commitment to integrating Complete Streets into all phases of capital project development and delivery.

### **DISCUSSION:**

VTA's proposed Complete Streets policy (Attachment A) defines Complete Streets and directs all VTA Divisions to formally incorporate Complete Streets within all transportation projects and funding programs. The policy also directs VTA to encourage Member Agencies to follow Complete Streets principles when delivering projects funded by VTA. Staff recommends that the Complete Streets policy be adopted via resolution, strengthening VTA's commitment to Complete Streets, and meeting requirements for 2016 Measure B.

The proposed Complete Streets policy is consistent with VTA's prior related policies, and is consistent with policies adopted by the U.S. Department of Transportation, Caltrans, and the Metropolitan Transportation Commission (MTC). Attachment B provides a timeline of key Complete Streets actions taken by these entities.

If adopted, the proposed Complete Streets policy will allow VTA to meet Complete Streets requirements for future One Bay Area Grant and 2016 Measure B funding programs.

### **Complete Streets Principles and Practices**

The principles and practices outlined in the proposed policy provide a strategy to achieve a system of complete streets. The policy takes the concept of "complete" beyond routine accommodation of non-motorized users to consider the life cycle of the street - from streetscape design, to geometric design standards, to the efficiency, maintenance and operations of the street system.

The proposed policy directs VTA to adhere to the following Complete Streets principles when administering transportation projects and programs:

1. Serve all users of the roadway, including pedestrians, bicyclists, and transit riders
2. Use context-sensitive design
3. Maintain or enhance network connectivity
4. Incorporate technology to improve operations and enhance safety of all roadway users
5. Are consistent with adopted plans
6. Maintain transportation infrastructure
7. Seek and respond to public input
8. Integrate Complete Streets infrastructure into transportation projects

## 9. Design using best practice guides and standards

### **Exceptions**

The expectation is that capital projects administered by VTA will incorporate pedestrian, bicycle, and transit infrastructure identified in local, countywide, or regional planning documents within the project's geographic limits. However, the policy recognizes that there may be circumstances where exceptions are permitted, including but not limited to: disproportionate cost relative to the overall project, areas where roadway users are legally prohibited, absence of existing and future need, or disproportionate adverse environmental or social impacts. The policy describes exceptions to this rule and directs VTA to document exceptions in writing and make them publicly available.

### **Evaluation**

Finally, the policy directs VTA to evaluate how effectively transportation projects meet their performance measures, including safety, use, and mobility.

### **ALTERNATIVES:**

The VTA Board of Directors could choose to modify or not adopt the resolution and associated Complete Streets Policy. If the policy is modified to eliminate one or more of the nine Complete Streets elements outlined by the Metropolitan Transportation Commission, VTA would not be eligible to receive capital funds under 2016 Measure B. Similarly, if VTA Board of Directors does not adopt the resolution establishing the policy, VTA would be ineligible to receive capital funds under 2016 Measure B.

### **FISCAL IMPACT:**

There is no fiscal impact as a result of this action. While some additional staff time will be required to implement the policy, it can be provided within currently approved staffing levels.

### **ADVISORY COMMITTEE DISCUSSION/RECOMMENDATION**

The Technical Advisory Committee received this item at the November 8, 2017 meeting. Members made the following comments: 1) one member requested that the policy be modified to indicate that if local design standards and Complete Streets best practices are in conflict the local design standards take precedence; 2) one member requested that minor comments he had emailed to staff prior to the meeting be incorporated; 3) members requested clarification of section 4D. The Committee voted unanimously to recommend the Board of Directors adopt the policy.

The Citizen's Advisory Committee (CAC) received this item at the November 8, 2017 meeting. Members made the following comments: 1) discussed how the policy could be used to address gaps in Complete Streets; 2) one member asked if the impacts of Complete Streets projects are being evaluated. Staff responded that the policy includes a recommendation to evaluate future

projects. The CAC met as a committee of the whole; no action was taken.

The Bicycle and Pedestrian Advisory Committee (BPAC) received this item at the November 8, 2017 meeting. During the discussion, members heard from the BPAC subcommittee that has been involved in reviewing the policy. The BPAC Complete Streets Subcommittee noted that they reviewed and commented on the policy the week prior, and requested that changes recommended by the subcommittee be incorporated. Subcommittee comments include: 1) noting that the Federal Highway Administration cost exception of 20% is advisory; 2) including Caltrans Class IV Bikeway guidance on the list of best practice design standards and guides; 3) tightening the exception language relating to detrimental environmental or social impacts; and 4) other minor wording changes.

BPAC members also made the following comments: 1) expressed the importance of bringing local projects to local BPACs for comment early in project development 2) requested that the policy be modified to require VTA to bring projects to local BPACs, with one member disagreeing, stating that the decision to bring a project to a local BPAC should rest with local staff; 3) one member believes that the language in 4A, “Complete Streets Principles and Practices” is inconsistent in its use of “must” and “should”; 4) requested clarification of section 4D, “Capital Projects Funded by VTA;” 5) requested that the language in section 3, “Transportation Funding” and section 4D be strengthened by changing “encourage” to “require”; 6) asked how “future need” would be determined per section 4B, “Exceptions to the Policy”; 7) recommended that the policy contribute to maintaining best practice designs across jurisdictional boundaries; 8) asked what happens if planning documents are not consistent with Complete Streets best practices; 9) asked if the policy covers future technology, such as automatic vehicles and staff replied that it does.

The BPAC voted unanimously to defer the item, requesting that staff bring a revised policy back to the committee, incorporating recommended changes to strengthen the policy, and include an explanation for changes not made.

The Committee for Transportation Mobility and Accessibility received this item at its November 9, 2017 meeting. The committee voted unanimously, without comment, to recommend Board of Directors adopt the policy.

The Policy Advisory Committee received this item at its November 9, 2017 meeting. The item was moved to the consent calendar. The committee voted unanimously, without comment, to recommend Board of Directors adopt the policy.

### **STANDING COMMITTEE DISCUSSION/RECOMMENDATION**

The Congestion Management Program & Planning Committee (CMPP) received this item at its November 16, 2017 meeting. Staff summarized the policy and highlighted the changes requested by Advisory Committees. Staff also indicated they would incorporate some of the changes requested and send the revised policy to BPAC prior to the Board of Directors meeting. Members made the following comments: 1) encouraged VTA to support physically separated bicycle lanes and asked if the policy could call this out; 2) requested clarification on the relationship of the VTA policy to 2016 Measure B Funds; 3) suggested staff consider changing language in the definition of Complete Streets (section 1) to state that projects should “improve”



conditions for pedestrians, bicyclists, and transit customers, rather than only stating that projects should “not degrade” conditions; 4) did not support the BPAC recommendation to change the language in section 4D from “encourage” to “require.” The committee voted unanimously to recommend the policy to the Board for adoption.

Prepared by: Lauren Ledbetter  
Memo No. 5806

**ATTACHMENTS:**

- Attachment A - Reso N Policy 11-30-2017 (PDF)
- Attachment B (DOCX)

**RESOLUTION NO. 2017.12.37**

**A RESOLUTION OF THE BOARD OF DIRECTORS OF THE  
SANTA CLARA VALLEY TRANSPORTATION AUTHORITY  
ADOPTING A COMPLETE STREETS POLICY**

**WHEREAS**, the Santa Clara Valley Transportation Authority (VTA), as the Congestion Management Agency for Santa Clara County, has the responsibility to ensure that all aspects of the transportation system are well planned, adequately funded, functioning efficiently, maintained, accessible and safe for all users; and

**WHEREAS**, the term “Complete Streets” describes a comprehensive, integrated transportation network that is planned, designed, operated, and maintained to provide safe mobility of all users of all ages and abilities, including bicyclists, pedestrians, transit vehicles, truckers, and motorists, appropriate to the function and context of the facility; and

**WHEREAS**, VTA acknowledges the benefits and value for the public health and welfare of reducing vehicle miles traveled and increasing transportation by walking, bicycling, and public transportation; and

**WHEREAS**, VTA recognizes that the planning and coordinated development of Complete Streets infrastructure provides benefits for local governments in the areas of infrastructure cost savings, public health, and environmental sustainability; and

**WHEREAS**, the State of California has emphasized the importance of Complete Streets by enacting the California Complete Streets Act of 2008 (also known as AB 1358), which requires that when cities or counties revise general plans, they identify how they will provide for the mobility needs of all users of the roadways, as well as through Deputy Directive 64R-2, in which the California Department of Transportation explained that it “views all transportation improvements as opportunities to improve safety, access, and mobility for all travelers in California and recognizes bicycle, pedestrian, and transit modes as integral elements of the transportation system”; and

**WHEREAS**, the California Global Warming Solutions Act of 2006 (known as AB 32) sets a mandate for the reduction of greenhouse gas emissions in California, and the Sustainable Communities and Climate Protection Act of 2008 (known as SB 375) requires emissions reductions through coordinated regional planning that integrates transportation, housing, and land-use policy, and achieving the goals of these laws will require significant increases in travel by public transit, bicycling, and walking; and

**WHEREAS**, Senate Bill 743 (Steinberg, 2013) and subsequent proposed guidelines by the Governor’s Office of Planning and Research revises the California Environmental Quality Act to “promote the reduction of greenhouse gas emissions, the development of multimodal transportation networks, and a diversity of land uses;” and

**WHEREAS**, numerous California counties, cities, and agencies have adopted Complete Streets policies and legislation in order to further the health, safety, welfare, economic vitality, and environmental wellbeing of their communities; and

**WHEREAS**, VTA has already adopted and implemented programs and practices equivalent to the Complete Streets concept such as the Community Design and Transportation (CDT) Program and the CDT Manual of Best Practices for Integrating Transportation and Land Use guidelines (2003), VTA’s Bicycle and Pedestrian technical guidelines (2012 and 2003), and a Multi-Modal Design Practices and Principles Approach for roadway improvement projects (2009); and

**WHEREAS**, on June 1, 2017, the Board of Directors of the Santa Clara Valley Transportation Authority (VTA Board of Directors) adopted the Complete Streets Reporting Requirements for 2016 Measure B, which require all project sponsors to adopt a Complete Streets resolution in order to be eligible to receive funding for capital projects from 2016 Measure B; and

**WHEREAS**, VTA therefore, in light of the foregoing benefits and considerations, wishes to improve its commitment to Complete Streets and desires that Santa Clara County be served by a comprehensive and integrated transportation network that promotes safe travel for all users, prioritizes the safety, comfort, and convenience of pedestrians, bicyclists, and transit riders of all ages and abilities, preserves flexibility, recognizes community context, and uses the latest and best design guidelines and standards;

**NOW, THEREFORE, BE IT RESOLVED**, that the VTA Board of Directors adopts the Complete Streets Policy attached hereto as Exhibit A, and made part of this Resolution.

**PASSED AND ADOPTED** by the Board of Directors of the Santa Clara Valley Transportation Authority, State of California, on December 8, 2017, by the following vote:

AYES: Bruins, Chavez, Diep, Hendricks, Jones, Khamis, Liccardo, O’Neill, Peralez, Vaidhyanathan, Yeager

NOES: None

ABSENT: Carr

ABSTAIN:None

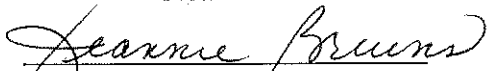
  
\_\_\_\_\_  
Jeanne Bruins, Chairperson  
Santa Clara Valley Transportation Authority

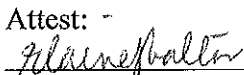
Attest: -  
  
\_\_\_\_\_  
Elaine Baltao, Board Secretary  
Santa Clara Valley Transportation Authority

Approved to as form:

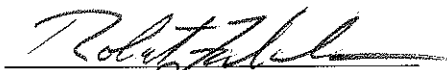
  
\_\_\_\_\_  
Robert Fabela, General Counsel  
Santa Clara Valley Transportation Authority  
Attachment: Exhibit A

## Complete Streets Policy Support

Complete Streets are supported by plans, guidelines, and policies from the U.S. Department of Transportation, Caltrans, the Metropolitan Transportation Commission, and VTA. A timeline of selected documents and policies is provided below.

- November 2002: VTA Board of Directors adopts the Community Design & Transportation (CDT) Program as its primary effort for linking transportation and land use. The CDT program outlines principles that are prescient of Complete Streets best practices that gain favor over the next several years.
- June 2006: Metropolitan Transportation Commission (MTC) adopts *MTC's Regional Policy for Accommodation of Bicycle and Pedestrian Facilities during Transportation Project Planning, Design, Funding, and Construction* (Resolution 3765), which requires project sponsors to submit a Complete Streets checklist for projects funded by MTC.
- September 2008: Governor Schwarzenegger signs into law the *Complete Streets Act of 2008*, (AB 1358) which requires that circulation elements of a city or county plan for a “balanced, multimodal transportation network that meets the needs of all users of streets, roads, and highways for safe and convenient travel in a manner that is suitable to the rural, suburban, or urban context of the general plan.”
- October 2008: Caltrans Department of Transportation (Caltrans) adopts *Complete Streets- Integrating the Transportation System* (DD-64-R-1), which directs the Agency to “ensure that travelers of all ages and abilities can move safely and efficiently along and across a network of ‘complete streets.’” It specifically calls out bicyclists, pedestrians and transit modes.
- January 2009: VTA Board of Directors adopts a policy, *Multi-Modal Design Practices and Principles*, which directs staff to follow the multi-modal design approach used for the US 101/Tully Road interchange project on all future roadway improvements, as feasible.
- January 2009: VTA establishes a Complete Streets program in the *Valley Transportation Plan 2035* and aligns funding to assist Member Agencies and VTA in delivering context-sensitive Complete Streets projects.
- March 2010: U.S. Department of Transportation issues a *Policy Statement on Bicycle and Pedestrian Accommodation Regulations and Recommendations*, which supports the development of fully integrated active transportation networks. The policy states that well-connected bicycle and pedestrian networks should be designed as part of Federal-aid projects.
- August 2010: VTA staff presents *Complete Streets Principles for Santa Clara County* (Memo No. 1543), to the VTA Board of Directors, which outlines a framework for a potential Complete Streets policy for Santa Clara County.

## Attachment B

- May 2012: MTC sets a Complete Streets requirement for local agencies to be eligible to receive federal and state transportation funding through the One Bay Area Grant (OBAG) program. VTA works with Member Agencies to certify that they have met the MTC requirements.
- October 2014: Caltrans updates its Complete Streets policy to direct the agency to provide for the needs of travelers of all ages and ability in planning, programming, design, construction, operations, and maintenance activities on the State highway system (DD 64-R-2). The policy is supported by Caltrans' *Complete Streets Implementation Action Plan 2.0*, adopted in 2014.
- June 2016: VTA includes a Complete Streets requirement in the policy language for 2016 Measure B, which subsequently is approved by voters in November 2016.
- June 2017: VTA Board of Directors approves the Complete Streets Reporting Requirements for 2016 Measure B. As described in the Reporting Requirements, project sponsors, including VTA, must have an adopted Complete Streets Policy in order to be eligible to receive 2016 Measure B funding.



**ATTACHMENT B:**  
VTA PLANTING GUIDELINES



**ATTACHMENT B:**

**B1: VTA PLANTING GUIDELINES**

# PLANT PALETTE RECOMMENDATIONS FOR SANTA CLARA VALLEY TRANSPORTATION AUTHORITY PROJECTS

Prepared For:

Santa Clara Valley Transportation Authority  
3331 North First Street, Building B  
San Jose, CA 95134-1927  
Contact: Kelly Snider

This Attachment Prepared By:  
RELM  
617 S. Olive Street | Suite 1110  
Los Angeles, CA 90014





# CONTENTS

|                                    |    |
|------------------------------------|----|
| Introduction                       | 3  |
| Species Selection Summary          | 5  |
| Landscape Typologies               | 7  |
| Trees Species List (fold out)      | 17 |
| Trees Species Photos               | 21 |
| Understory Species List (fold out) | 30 |
| Understory Species Photos          | 39 |
| References                         | 48 |



# INTRODUCTION

To assist in the design and development of Transit Oriented Development projects at Valley Transportation Authority (VTA), Landscape Architects at RELM collaborated with VTA to develop this landscape planting guide in line with the recommendations outlined in the VTA's Green Building and Sustainable Landscape Policy. This document is intended to serve as a 'quick-start' guide for selecting plants that work well with the majority of landscape typologies utilized in TOD projects in the San Jose Area. Included in this recommendation, is a list of drought-tolerant tree and understory species that can be incorporated into TOD planting designs to create ecologically functional landscapes that will shape the new urban centers TOD projects engender.

This document includes a pre-approved list of plant species to select from that meet the intent of the VTA Green Building and Sustainable Landscape Policy Standards. This list is not comprehensive and additional species may be brought to VTA for approval.

This document acts as a plant-focused supplement to the lengthier VTA Sustainable Landscape Policy, the VTA Landscaping and Stormwater Design Criteria Manual, and (where applicable for City/County stormwater facilities) the Santa Clara Valley Urban Runoff Pollution Prevention (SCVURPP) Design Criteria Guidelines. The full documents are referenced frequently during the design process for all TOD projects. The primary goals of these documents as they relate to landscape planting are reiterated here for quick reference.

1. Conserve Water Resources
  - Use low water-use, drought-tolerant, climate-adapted plants
  - Plant low maintenance, drought tolerant or native plant species
  
2. Reduce or Prevent Pollution
  - Plant low maintenance plants that require minimal fertilizers, pesticides and herbicides.
  - Refer to the Santa Clara Valley Urban Runoff Pollution Prevention Program's Planting Guidance for Landscape-Based Stormwater Measures, C.3 Storm water Handbook, Appendix D, for plants appropriate for various biofiltration methods.
  
3. Improve Wildlife Habitat and Biodiversity
  - Select plants native to California that provide habitat and food for birds, insects, and other wildlife;
  - Under no circumstances shall any plants listed as invasive by the California Invasive Plant Council's Invasive Plant Inventory be used for landscaping.

## SPECIES SELECTION SUMMARY

### TREES

Growing healthy, enduring trees in urban environments is inherently difficult, and current climatic fluctuations are exacerbating the challenges. Fortunately, there are many organizations researching and publishing on the topic with a selection listed below.

- CANOPY (<https://canopy.org/>)
- San Francisco Estuary Institute (<https://www.sfei.org>)
- Urban Forest Ecosystems Institute: Cal Poly (<https://selectree.calpoly.edu/>)
- Our City Forest ([www.ourcityforest.org](http://www.ourcityforest.org))
- Stanford University - Tree List of Campus Trees (<http://trees.stanford.edu/>)
- City of San Jose Community Forest Management Plan. (<https://sanjosecfmp.com>)

A review of recent work coming out of these municipal, non-profit and academic organizations demonstrates consensus on the importance of species diversity in maintaining a healthy urban forest. In general, the ideal distribution of any single tree species is recommended to be no more than 10% of the total tree quantity within a designated area. According to the recently published City of San Jose Tree Policy Manual, San Jose's current street tree make up includes four species that currently exceed the 10% capacity rule, namely Chinese Pistache (*Pistacia chinensis*), Crape Myrtle (*Lagerstroemia* spp.), London Plane (*Platanus acerifolia*) and Western Sycamores (*Platanus racemosa*). These species are no longer approved for new plantings within San Jose city limits. These four species are included on the VTA species list due to the occasional need to match existing street tree species, but are not recommended for new plantings.

Another critical criteria for tree selection is the estimated water use of a given species. In general, trees selected for the VTA approved list are in the low water use WUCOLS category for the San Jose area. However, select moderate water use trees which are deemed climate appropriate when used in the correct location (i.e. bioswale or riparian) are included given the variety of microclimates encompassed by VTA TOD project sites. These plants may be included in TOD sites provided that the total calculated water use demonstrates the project site will still be in compliance with the Maximum Applied Water Allowance (MAWA) per Cal Green.

### UNDERSTORY

Understory species listed here are all climate appropriate for the South San Francisco Bay Area. The vast majority are low-water use, with some moderate water use species included for select appropriate micro-climates (shaded north-facing facades, riparian waterways, etc.) with minimal use.

The use of native plants is encouraged as native plants support native wildlife, however, select adapted and well-suited plants from other Mediterranean areas are included on this list. Native plants are an important component and provide habitat value to a variety of native insects, however urban sites occasionally benefit from natives intermixed with hearty, non-native plants that may originate from similar climates such as Australia or the desert southwest and may be very appropriate to the Bay Area as the summers get hotter. In general, TOD plant palettes should strive to be a minimum of 70% native species.

A diverse list of plants is offered most of which are on the Santa Clara Valley Water District list for lawn-replacement plants and meet MWELC Cal Green Requirements. Many plants overlap with those listed in Appendix D of SCVURPPP's C.3 Stormwater Handbook. Given that VTA land traverses multiple municipalities, plants on this list should be cross-checked with current local municipal tree and landscape guidelines as well as local soil conditions, micro-climates and adjacencies.

Species are characterized by plant type, as listed below which, in nature work together to create habitats that are structurally rich. Where possible, multiple plant types should be used together to create layered plantings to maximize habitat value. Upon project completion, natural plant maintenance training is recommended for contracted maintenance companies to achieve lasting aesthetic and ecological functionality.

The majority of species listed are readily available in the nursery industry, especially some of the many native plant nurseries in the Bay Area. The list is also available in Excel and intended to be sortable based on needs of a given TOD project. The list is not exhaustive and additional plants may be proposed and approved by VTA.

#### **SITE SPECIFIC CONDITIONS: SOILS, HYDROLOGY**

The Santa Clara Valley has soil and hydrologic conditions that vary greatly depending on location. Low lying areas near the Bay are predominately clay soils that are inherently difficult to drain. In these areas, planting soil for TOD landscapes should be amended and supplemental drainage added. Other areas, such as those along drainage ways, are underlain with fast draining alluvium soils suitable to a variety of native species. Much of San Jose is subject to intermittent flooding and select TOD sites will be located atop a very high ground-water table, similar to the Berryessa Bart Station location. Other areas within the South Bay are underlain with sandy loam soil that supported farms and orchards for much of the last century. Plants should be tailored to soil type and drainage patterns of specific to each TOD location.

#### **IRRIGATION TYPE / WATER SOURCE**

A factor that must be considered when planting in the urban South Bay is the use of recycled water for irrigation. Although water quality will vary depending on water provider, in general, recycled water is higher in salts and other dissolved particulates that can negatively impact plant establishment and long term health. It is recommended that landscape designers review a water quality report from the water provider to obtain salinity levels of recycled water available for irrigation prior to plant selection.

Irrigation quantity, frequency and method of application can be tailored to render the best possible soil conditions using the available water. In general, plants are more susceptible to salt damage from direct contact (spray) than when applied to soil and roots (drip). Salt tolerance, when known, is listed in the plant lists and salt-tolerant species should be favored for sites irrigated with recycled water. References for further study are included in the Reference section.

## TOD LANDSCAPE TYPOLOGIES

Although the specific planning and development goals for each TOD project will vary, as will the site conditions, there is a common set of landscape elements that will typically combine in various forms to create the TOD landscape. Working together, RELM and VTA defined nine landscape typologies common to the public spaces of TOD projects. Private courtyards and roof terraces were purposely excluded from this document as they do not comprise the public space of TODs. Descriptions of each typology are found on the following pages. Approved plants are tagged with the typologies for which they are appropriate. Most plants can be applied to more than one typology.

- Major Streets (4+ lanes of traffic)
- Minor Streets (2+ lanes of traffic)
- Paseo (pedestrian)
- Plaza
- Passive green space
- Surface parking lots
- Biofiltration and Bioswales
- Riparian
- Landscape Buffers and Slopes

**MAJOR STREETScape (4+ lanes vehicular traffic)**

Many TOD sites will include major vehicular streets, those with four or more lanes of traffic. These streets should be designed to encompass elements that yield 'Complete Streets' prioritizing pedestrian, bicycle and public transportation modes. Street trees on larger streets serve to separate pedestrian and vehicular zones, provide shade and encourage walk-ability. Trees should be coordinated with other streetscape features such as street lights, trash and recycling receptacles, signage, bicycle parking and outdoor seating, among others. Existing street trees and/or municipal street tree plans should be consulted for each TOD site and, where possible, followed within the TOD landscape plans.

Street trees on major streets need to be of large enough stature when mature to allow for transit flow beneath them (bus, light rail), typically 15'-20' high. Adequate soil rooting volume is critical for long term health and viability of street trees. Minimum tree-pit openings should be 5' wide x 12'-18' long. Continuous parkways between the pedestrian sidewalk and vehicular street are preferred, with breaks as needed for pedestrian crossings. Recommended spacing between trees is 25'-30' on center. Understory plantings should be included where possible and planted with relatively uniform species distribution.

**Characteristics of Major Streetscape Trees:**

- Central Leader
- High Branching, 8' min. clear over sidewalk at install, growing to 15'-20' clear
- Strong wooded and good structure with minimal ongoing pruning required
- Contained root system, minimal pavement uplift
- Disease and pest resistant
- Minimal fruit litter

**Characteristics of Major Streetscape Understory Plantings:**

- Height between 18" - 24" tall to maintain visibility between street and sidewalk.
- Evergreen dominated plant mix with scattered perennials if desired for color
- Low maintenance



High branched, limbed up trees



Trees and understory combined



Kennedy Plaza, DG with street trees

**MINOR STREETScape (1-2 lanes vehicular traffic)**

The smaller streets within TOD sites allow for more equal distribution of pedestrian / active transport zone (bikes, scooters, e-bikes) and vehicular traffic zones. Streetscape planting should reflect this shift to the pedestrian scale by offering more variation and seasonal interest. Species selection can be more focused on the local site-design strategy rather than larger city-wide plans. Tree spacing can be reduced to every 20'-25' allowing for species of smaller mature stature to be planted in smaller planting areas. Traffic calming measures such as planted parkways and curb bulb-outs offer more room to insert diverse trees and plants. Understory planting should remain focused on visibility, maintenance and durability, but can begin to expand in species diversity with added hardy perennials.

Development sites require emergency vehicle access routes (EVAs) integrated within the new built fabric. These should be treated as minor streets in terms of planting and would serve primarily as pedestrian and active transit only routes. Trees and planting along these routes should be designed to provide sufficient room for maneuvering of large emergency vehicles and their required outriggers while also creating a comfortable pedestrian environment.

**Characteristics of Minor Streetscape Trees:**

- Central Leader or whorled branching structure trained to be upright
- High Branching, 8' min. clear over sidewalk, growing to 10-15' clear
- Strong wooded and good structure with minimal ongoing pruning required
- Contained root system, minimal pavement uplift
- Disease and pest resistant

**Characteristics of Minor Streetscape Understory Plantings:**

- Height between 18" - 24" tall to maintain visibility between street and sidewalk.
- Low maintenance



Smaller stature trees



Mixed understory planting



Continuous Parkway

## PASEO

Paseos, or small streets without consistent vehicle traffic will interweave through new TOD sites, creating routes for pedestrian and active (bike, scooter, e-bike) transportation. These linear public open spaces should be planted in such a way to encourage walkability and outdoor social interactions with shade, seasonal interest and spaces for social interaction. The narrow configuration of these spaces creates shady, protected planting areas which can be planted with a diversity of native small trees and understory plants. Adequate rooting volume is required and construction details that allow for planting soil to be extended beneath pedestrian pavement should be explored.

### Characteristics of Paseo Trees:

- Deciduous - seasonal color, allow winter light down to ground surface
- Narrow, Upright or Smaller Stature
- Strong structure (minimal risk of branch failure)
- Minimal pavement uplift

### Characteristics of Paseo Understory Plantings:

- Height can vary depending on local adjacencies, taller narrow shrubs may work in some areas, more sculptural small trees can be planted where space allows.
- Combination of evergreen and flowering
- Low maintenance



Narrow, upright trees to allow emergency vehicle access



Mixed scale of trees and plantings



# PLAZAS

TOD projects are inherently spaces where people come to gather in the public realm. Plazas at station entries, intersections and associated with retail development are a critical component of these new urban centers. Trees and plants play a significant role in these plazas, providing shade and serving as the 'ceiling' for these outdoor 'living rooms.' Plazas are dynamic spaces, at times hosting large civic and cultural events, food trucks and farmers markets and at other times being quiet spaces operating as 'outdoor living rooms' for the local residents and transit users. Tree planting must be able to support these diverse programmatic uses and soil should be designed in such a way that allows trees to thrive in a hardscape condition. Where possible, understory planting should be included, but should be durable and able to withstand foot traffic.

### Characteristics of Plaza Trees:

- Shade trees
- Single specimen trees if large plant bed is available
- Groves of central leader trees.... High Branching
- Small Groupings of smaller trees, multi-stem to create definition at edges
- Seasonal color / Deciduous

### Characteristics of Plaza Understory Planting:

- Tolerant of foot traffic



Paved or Artificial Turf area with Trees



Tree Grates



Trees in large openings

# PASSIVE GREEN SPACE

TOD sites will have a variety of passive green spaces which serve as interstitial space between and around buildings, plazas and parking areas. Trees in these areas can be wider and more low-branched than trees occupying spaces with pedestrians and traffic. These are areas that can support greater diversity within plant beds and support a variety of native species.

Select areas may be occupiable and planted with typical low-water use turf lawn or a natural lawn such as a no-mow fescue or sedge meadow. Non-occupiable plant beds shall be planted with a mix of flowering and evergreen species.

- Characteristics of Passive Green space Trees:
- Shade Trees
  - Smaller, understory trees, flowering accents
  - Upright trees for narrow spaces, tall hedge-like species

- Characteristics of Passive Green space Understory Plantings:
- Fescue or No-Mow lawn or native sedges meadow
  - Diverse blend of perennials, range of heights
  - Seasonal interest



Lawn, bioswale and plant bed cohesively planted



Multi-species planting



Diverse species, bloom times and structure

## BIORETENTION AND BIOSWALES

Bioretention, bioswales and green infrastructure are a critical landscape component of all TOD projects in terms of managing stormwater pollution. To that end, VTA developed a detailed Stormwater and Landscaping Design Criteria Manual (DCM) that outlines various stormwater management strategies and the associated permit process, and is applicable not only to TOD projects but to all VTA sites. While the DCM includes a list of acceptable plants by VTA stormwater management type, this TOD focused document includes a selection of species applicable to all types of stormwater management and serves as a good starting point for TOD plant selection. Further detail can be found in the DCM.

Not all bioretention basins and bioswales can support trees, but where applicable trees should be included to provide additional habitat value. Note that both the trees and understory species in bioretention basins and bioswales should tolerate both wet and dry conditions. Also, in facilities where an underdrain is required, the roots of trees and large shrubs may grow into the slots of the underdrain pipe which can lead to increased maintenance and/or result in reduced performance of the basin which shortens the life of the bioretention facility. Thus, planting design in and these areas with an underdrain should be given careful consideration. Finally, in facilities with a liner, special care must be taken in the planting palette and design of the facility to accommodate plant health, and typically trees cannot be accommodated when a liner must be used.

### Characteristics of Bioretention and Bioswale Trees:

- Tolerant of both inundated and dry conditions
- Minimal leaf litter which can prevent proper filtration capacity if not maintained

### Characteristics of Bioretention and Bioswale Understory Plantings:

- Tolerant of both inundated and dry conditions
- Not too tall as to block irrigation heads



Berryessa Station Bioretention Basin



Sample Streetscape Bioswale



Milpitas Station Bioswale

# SURFACE PARKING LOTS

Parking lots will be a component of many TOD projects and should be designed to have as much integrated planting as possible. Per current Cal Green Code, at least fifty percent of the parking area is required to be shaded within fifteen years after the establishment of the lot which can be provided by a combination of PV panel structures and trees. Thus, trees should be relatively fast growing but also long-lived and spreading. It is critical that parking lot trees are provided with the rooting volume of un-compacted soil to allow trees to thrive. Often, trees in small tree pits are seen in poor condition as early as 2-5 years after planting. Structural soil (CU Mix) is one option that can extend rooting area beneath the asphalt pavement surface with relatively minimal cost increase.

Bioretention basins and bioswales are often closely tied with the parking lots and available planting area will often have to serve two purposes - providing shade, habitat and stormwater management.

- Characteristics of Parking Lot Trees:
- Upright
  - Fast Growing or Mix of Fast and Moderate Growing
  - Strong structure (minimal risk of branch failure)
  - Many species will overlap with Bioretention and Bioswale Tree List

- Characteristics of Parking Lot Understory Plantings:
- Evergreen and Flowering



Evergreen groundcover with trees



Bioswale with trees and minimal planting



Bioswale and Planting with Trees

**RIPARIAN / NATURAL EDGES**

In areas where a TOD Site is located adjacent to a designated Creek or Waterway, extreme care must be taken to follow planting guidelines prescribed by the Santa Clara Valley Water District in order to protect habitat, stream stability, water quality and flood protection.

In areas within a 50' min. buffer from Top of Bank, Santa Clara Valley Water District requires the use of locally native plants. These plants are to be propagated from seeds, cutting or divisions collected from lame local creek or watershed and grown according to criteria listed in Santa Clara County Water District – to prevent spread of Sudden Oak Death. Care should be taken to minimize impact to existing native vegetation along creeks.

In areas adjacent to Creeks and drainages but not directly within the buffer zone, local native species should be planted to maximize habitat value.

- Characteristics of Riparian Trees:
- Native
  - Habitat Value
  - Non-Invasive (including invasive natives)

- Characteristics of Riparian Understory Plantings:
- Native
  - Habitat Value
  - Non-Invasive (including invasive natives)



Naturally planted riparian habitat area



Grasses with leaf litter, natural design, no irrigation



Deer Grass in public park adjacent to creek



Alnus rhombifolia, only near creek

**GRADE SEPARATION / SLOPES / LANDSCAPE BUFFERS**

Perimeters of the development areas and any easements or landscape adjacent to public lands should have a native palette so they serve as habitat corridors and require minimal to no supplemental irrigation post establishment. Species diversity in both tree and groundcover layers is recommended to promote year-round flowers and fruits. One of the most common species on the slopes of the Santa Clara Valley is the California Buckeye, and this tree should be used when possible in these conditions.

For slopes greater than 3:1, biodegradable (not plastic-woven) erosion control netting is recommended and trees should be installed at a smaller box size (24" or 36" box). Installing smaller trees does require slightly more maintenance during the first 1-2 years post installation in order to have an arborist prune the trees as they mature to encourage healthy structure that will require less maintenance over time. Grasses and spreading groundcovers are recommended understory species with intermittent native shrubs to enhance woodland structure and habitat value.

Characteristics of Slope / Buffer Trees:

- Native, natural forms or multi-stem
- Habitat Value

Characteristics of Understory Slope / Buffer plantings:

- Fast-growing
- Spreads by Rhizomes or Deep roots of perennial grasses
- Low maintenance



Sedge or Grass slope



Mixed shrub planting for buffer area



Naturally planted slope, groundcovers and scattered native shrubs



Mixed shrub and perennial edge planter

## TREE SPECIES PLANT LIST

The following plant list includes trees species recommended for use at TOD projects.

Basic species information is provided. Species have an X in the box for each Landscape Typology for which they are appropriate.

\* Water Use Information provided by WUCOLS for San Jose, from [https://ucanr.edu/sites/WUCOLS/Plant\\_Search/](https://ucanr.edu/sites/WUCOLS/Plant_Search/)

VL = very low water use L=low water use, M=moderate water use (use sparingly, highlighted in blue), H=high water use (not recommended)

\*\* Salt Tolerance Information as available from varied sources.

H = highly tolerant, M = moderately tolerant, will typically show minimal symptoms, L= not tolerant/ sensitive, will exhibit symptoms

\*\*\* Species not recommended for planting in City of San Jose. Do not use on TOD sites unless needed to match existing street trees.

California Native Species highlighted in yellow

| Latin Name                                 | Common Name                       | Comments/ Notes  | Decid / Evgrn / Flwr / Confr / Shrub-like | Mature Size H' X W' | WATER USE WUCOL San Jose* | Salt Tolerance for RCW (H,M,L)** | CA Native (Y/N) | TYPOLOGIES | MAJOR STREETSCAPE | MINOR STREETSCAPE | PASEOS | PLAZAS | PASSIVE GREEN SPACE | PARKING LOT | RIPARIAN | SLOPE - BUFFER | BIORETENTION |
|--|-----------------------------------|--|---|---------------------|---------------------------|----------------------------------|-----------------|------------|-------------------|-------------------|--------|--------|---------------------|-------------|----------|----------------|--------------|
| <i>Acer buergerianum</i>                   | Trident Maple                     | Non, native but may be better at handling summer drought of bioswales    | Decid                                     | 25'-30' x 25'-30'   | M                         | M                                | N               |            |                   | X                 | X      |        |                     |             |          |                | X            |
| <i>Acer macrophyllum</i>                   | Big Leaf Maple                    | Shade, consistent moisture, protected                                    | Decid                                     | 30-75' x 30-50'     | M                         | M                                | Y               |            |                   |                   |        |        | X                   |             | X        |                | X            |
| <i>Acer negundo californicum</i>           | California Box Elder              | Fall color, may be slightly more drought tolerant than Acre macrophyllum | Decid                                     | 20'-30' x 20'-30'   | M                         | L                                | Y               |            |                   |                   |        |        |                     |             | X        |                | X            |
| <i>Aesculus californica</i>                | Califronia Buckeye                | Wildlife value, Summer Deciduous   | Decid / Flwr                              | 20-30' x 15-30'     | L                         | L /M                             | Y               |            |                   |                   |        |        | X                   |             | X        | X              |              |
| <i>Afrocarpus gracilior</i>                | African Fern Pine                 | Find Good Proven Example   | Evgrn / Conifer                           | 50-65' x 20-30'     | L                         | M                                | N               |            | X                 |                   |        |        |                     | X           |          |                |              |
| <i>Agonis flexuosa</i>                     | Peppermint Tree                   |  | Evgrn                                     | 25-35' x 15'-30'    | M                         | M                                | N               |            |                   | X                 |        |        |                     | X           |          | X              |              |
| <i>Alnus rhombifolia</i>                   | White Alder                       | Water - But Riparian, Bioswale   | Decid / Flwr                              | 50-90' x 40-70'     | M                         | M                                | Y               |            |                   |                   |        |        |                     |             |          |                | X            |
| <i>Arbutus unedo</i>                       | Strawberry Madrone                | Single Stem, Fruiting, Not over Pvmt                                     | Evgrn / Flwr                              | 20-30' x 15-40'     | L                         | M                                | N               |            |                   |                   |        |        |                     |             |          | X              |              |
| <i>Arbutus x 'Marina'</i>                  | Marnia Madrone                    | Standard for Streets/Pkg Lots, Mutli for Planting                        | Evgrn / Flwr                              | 40-50' x 25-40'     | L                         | M                                | N               |            |                   |                   | X      |        | X                   |             |          |                |              |
| <i>Brachychiton populneus</i>              | Kurrajong                         | Pale Cream Flowers   | Decid / Flwr                              | 50-60' x 30-40'     | L                         | M                                | N               |            |                   |                   |        |        | X                   |             |          |                |              |
| <i>Calocedrus decurrens</i>                | Incense Cedar                     | Large planting area required   | Conifer                                   | 50'-80" x 30-40'    | L                         | L                                | Y               |            |                   |                   |        |        | X                   |             |          | X              |              |
| <i>Carpinus betulus</i>                    | Fastigate European Hornbeam       | Hedge, Perimeter   | Decid / Flwr                              | 35-40' x 20-30'     | M                         | M                                | N               |            |                   |                   |        |        |                     |             |          | X              |              |
| <i>Cedrus atlantica glauca 'fastigata'</i> | Columnar Blue Atlas Cedar         | Good Narrow Tree - Screen, Hedge   | Conifer                                   | 40-60' x 25-40'     | L                         | M                                | N               |            |                   |                   | X      |        |                     |             |          | X              |              |
| <i>Cedrus deodara</i>                      | Deodar Cedar                      | Large planting area required   | Conifer                                   | 40-60' x 20-30'     | L                         | M                                | N               |            |                   |                   |        |        | X                   |             |          | X              |              |
| <i>Celtis laevigata var. reticulata</i>    | Netleaf Hackberry (Western Hackb) | Dry fruit litter   | Decid                                     | 25'-30' x 25'-30'   | L                         | L/M                              | Y               |            |                   |                   |        |        |                     |             |          |                | X            |

## TREE SPECIES PLANT LIST

| Latin Name  | Common Name             | Comments/ Notes   | Decid / Evgrn /<br>Flwr / Confr /<br>Shrub-like | Mature Size<br>H' X W' | WATER<br>USE<br>WUCOL<br>San<br>Jose* | Salt<br>Tolerance<br>for RCW<br>(H,M,L)** | CA<br>Native<br>(Y/N) | TYPOLOGIES | MAJOR<br>STREETSCAPE | MINOR<br>STREETSCAPE | PASEOS | PLAZAS | PASSIVE GREEN SPACE | PARKING LOT | RIPARIAN | SLOPE - BUFFER | BIORETENTION |
|---|-------------------------|---|---|------------------------|---------------------------------------|---|-----------------------|------------|----------------------|----------------------|--------|--------|---------------------|-------------|----------|----------------|--------------|
| <i>Celtis sinensis</i>                                  | Chinese Hackberry       | Dry fruit litter suseptible to Asian woolly aphid                                 | Decid   | 25-35' x 25-30'        | L                                     | L   | V                     |            |                      |                      |        |        |                     |             |          |                | X            |
| <i>Cercis canadensis var. texensis</i>                  | Oklahoma Redbud         | Smaller, Bushier Tree   | Decid / Flwer                                   | 25-35' x 25-35'        | L/M                                   | L   | N                     |            |                      |                      |        |        |                     |             |          | X              |              |
| <i>Cercis occidentalis</i>                              | Western Redbud          | Local native, flowering, needs good drainage                                      | Decid / Flwer                                   | 12-20' x 20-15'        | L                                     | M   | Y                     |            |                      |                      | X      |        | X                   |             | X        | X              |              |
| <i>Chilopsis linearis 'Bubba'</i>                       | Desert Willow           | Small flowering accent tree, native to southern Cali                              | Decid / Flwer                                   | 12-20' x 10-15'        | L                                     | H   | Y                     |            |                      |                      | X      |        | X                   | X           |          | X              |              |
| <i>Chionanthus retusus</i>                              | Chinese Fringetree      | Small flowering accent tree   | Decid / Flwer                                   | 10-20' X 6-12'         | M                                     | M   | N                     |            |                      |                      | X      |        |                     |             |          |                |              |
| <i>Chitalpa tashkentensis 'Pink Dawn'</i>               | Pink Dawn Chitalpa      | Cross between Catalpa nad Chilopsis, Smaller flowering tree                       | Decid / Flwer                                   | 25-35' x 25-35'        | L                                     | M   | N                     |            |                      | X                    | X      | X      |                     | X           |          |                |              |
| <i>Corylus cornuta var. californica</i>                 | Western Hazelnut        | Shade only, protected areas   | Decid / Flwer                                   | 15-18' x 12-18"        | M                                     | M   | Y                     |            |                      |                      | X      |        |                     |             | X        | X              |              |
| <i>Corymbia ficifolia</i>                               | Red Flowering Gum       | Good Wildlife Plant, Salt Tolerant  | Evgrn / Flwer                                   | 18-45' x 15-60'        | L                                     | H   | N                     |            | X                    |                      |        |        |                     |             |          |                |              |
| <i>Fraxinus latifolia</i>                               | Oregon Ash              | Generally not recommended, Weak wooded, Emerald Ash Borer but could               | Decid   | 65-80' x 50'           | M                                     | M   | Y                     |            |                      |                      |        |        |                     | X           |          |                | X            |
| <i>Fraxinus velutina</i>                                | Arizona Ash             | Weak wooded, Emerald Ash Borer, older trees require significant                   | Decid   | 30-50' x 30-40'        | M                                     | M   | Y                     |            |                      |                      |        |        |                     | X           |          |                | X            |
| <i>Geijera parviflora</i>                               | Australian Willow       | More commonly planted in southern CA, select good structure in nursery            | Evergreen                                       | 25-35' x 20'           | L                                     | H   | N                     |            | X                    | X                    |        |        |                     | X           |          |                |              |
| <i>Ginkgo biloba "Autumn Gold"</i>                      | Maidenhair Tree         | Can turn back to female, Use sparingly in narrow conditions for yellow fall color | Decid   | 25-50' x 25-35'        | M                                     | L   | N                     |            |                      | X                    | X      |        |                     |             |          |                |              |
| <i>Gledistia triacanthos var. inermis 'Shademaster'</i> | Thornless Honey Locust  | Fast growing, minimal seed pods, ensure good structure at nursery                 | Decid / Flwer                                   | 45' x 35'              | L                                     | L   | N                     |            |                      | X                    | X      | X      |                     |             |          |                |              |
| <i>Hesperocyparis arizonica</i>                         | Arizona Cyress          | Screen tree, can be used at edges of bioswales                                    | Conifer   | 30-40' x 15-20'        | L                                     | H   | N                     |            |                      |                      |        |        | X                   |             |          | X              |              |
| <i>Hesperocyparis forbesii</i>                          | Tecate Cypress          |   | Conifer   | 10-25' x 20'           | L                                     | H   | Y                     |            |                      |                      |        |        | X                   |             |          | X              | X            |
| <i>Juglans californica</i>                              | California Black Walnut | Drops large fruit, Not over pedestrian areas                                      | Decid   | 15' - 30' x 15' - 30'  | L                                     | L   | Y                     |            |                      |                      |        |        |                     |             | X        | X              | X            |
| <i>Koelreuteria bipinnata</i>                           | Chinese Flame Tree      | Good shade trees  | Decid / Flwer                                   | 20-35' x 25-40'        | M                                     | M   | N                     |            | X                    | X                    |        | X      |                     | X           |          |                |              |
| <i>Lagerstroemia spp. (Not Recommended) ***</i>         | Crepe Myrtle ***        | Only to match existing street trees, over planted in San Jose                     | Decid / Flwer                                   | 25' x 25'              | L                                     | L   | N                     |            |                      |                      |        |        |                     |             |          |                |              |
| <i>Laurus nobilis</i>                                   | Grecian Laurel          | Sensitive to clay soils and poor drainage, plant only in bioswales                | Evgrn   | 15-20' x 20-25'        | L                                     | M   | N                     |            |                      |                      |        |        |                     |             |          |                | X            |
| <i>Lophostemun confertus</i>                            | Brisbane Box            |   | Evgrn / Flwer                                   | 30-50 x 10-30'         | L                                     | M   | N                     |            | X                    | X                    |        |        |                     | X           |          |                |              |
| <i>Lyonothamnus floribundus</i>                         | Catalina Ironwood       | Needs drainage, good in tight groves  | Evgrn / Flwer                                   | 25-50' x 12-24'        | L                                     | M   | Y                     |            |                      |                      | X      |        | X                   |             |          | X              |              |



## TREE SPECIES PLANT LIST

| Latin Name   | Common Name                 | Comments/ Notes  | Decid / Evgrn /<br>Flwr / Confr /<br>Shrub-like | Mature Size<br>H' X W' | WATER<br>USE<br>WUCOL<br>San<br>Jose* | Salt<br>Tolerance<br>for RCW<br>(H,M,L)** | CA<br>Native<br>(Y/N) | TYPOLOGIES | MAJOR<br>STREETSCAPE | MINOR<br>STREETSCAPE | PASEOS | PLAZAS | PASSIVE GREEN SPACE | PARKING LOT | RIPARIAN | SLOPE - BUFFER | BIORETENTION |
|--|-----------------------------|--|---|------------------------|---------------------------------------|---|-----------------------|------------|----------------------|----------------------|--------|--------|---------------------|-------------|----------|----------------|--------------|
| <i>Maleleuca ericifolia</i>                        | Swamp Paperbark             | Salt tolerant  | Evgrn / Flwer                                   | 20-40' X 15-25'        | L                                     | H   | N                     |            |                      |                      |        |        | X                   |             |          |                |              |
| <i>Melaleuca stypheliodes</i>                      | Prickly Paperbark           | Salt tolerant, often multi-trunked   | Evgrn / Flwer                                   | 30-40' x 10-20'        | L                                     | M   | N                     |            |                      |                      | X      |        | X                   | X           |          |                |              |
| <i>Metrosideros excelsa</i>                        | New Zealand Christmas Tree  |  | Evgrn / Flwer                                   | 30-35' x 30-35'        | L                                     | M   | N                     |            |                      | X                    | X      |        |                     | X           |          |                |              |
| <i>Olea europea 'Swan Hill'</i>                    | Fruitless Olives            | also Wilsonii, multitrunk - can be limbed up to height of 8' clear if needed     | Evgrn   | 25-30' x 25-30'        | L                                     | M   | N                     |            |                      |                      | X      | X      | X                   | X           |          |                |              |
| <i>Parkinsonia x 'Desert Museum'</i>               | Palo Verde                  | Native to desert southwest   | Decid / Flwer                                   | 15-25' x 15-20'        | L                                     | H   | Y                     |            |                      |                      | X      | X      | X                   |             |          |                |              |
| <i>Pinus eldarica</i>                              | Mondell Pine                | Tolerates Clay Soi   | Conifer   | 30-80' x 15-25'        | L                                     | M   | N                     |            | X                    |                      |        |        |                     | X           |          | X              |              |
| <i>Pinus torreyana</i>                             | Torrey Pine                 | Very large cones, not over pedestrian/parking areas                              | Conifer   | 40-60' x 20-30'        | L                                     | M   | Y                     |            |                      |                      |        |        |                     |             | X        | X              |              |
| <i>Pistacia chinensis (Not Recommended) ***</i>    | Chinese Pistache ***        | Only to match existing street trees, overplanted in San Jose                     | Decid / Flwer                                   | 25-35' x 25-35'        | L                                     | M   | N                     |            |                      |                      |        |        |                     |             |          |                |              |
| <i>Plantanus racemosa</i>                          | Western Sycamore            | Use in bioswales, Ensure that nursery stock is straight species, not hybridized. | Decid   | 30-80' x 20-50'        | M                                     | M   | Y                     |            |                      |                      |        |        |                     |             |          |                | X            |
| <i>Platanus x acerifolia (Not Recommended) ***</i> | London Plane Tree ***       | Only to match existing street trees, overplanted in San Jose                     | Decid   | 70-85' x 50-70'        | L                                     | M   | N                     |            |                      |                      |        |        |                     |             |          |                |              |
| <i>Populus fremontii</i>                           | Fremont Cottonwood          | gold fall color, surface roots, weak branches                                    | Decid   | 40-80' x 30-50'        | M                                     | M   | Y                     |            |                      |                      |        |        |                     |             | X        |                | X            |
| <i>Propospis glandulosa 'Maverick'</i>             | Thornless Honey Mesquite    | Spreading, need sufficient planter width, Native to desert southwest             | Decid / Flwer                                   | 25-35' x 20-35'        | N/A                                   | H   | Y                     |            |                      |                      |        |        | X                   | X           |          |                |              |
| <i>Prunus ilicifolia ssp. lyonii</i>               | Catalina Cherry             | Wildlife value, fruiting, good screen  | Decid / Flwer                                   | 25-35' x 20-30'        | L                                     | M   | Y                     |            |                      |                      |        |        |                     |             | X        | X              |              |
| <i>Prunus serrulata 'Kwanzan'</i>                  | Japanese Flowering Cherry   | Needs good drainage, no clay soils   | Decid / Flwer                                   | 30' x 20-30'           | M                                     | M   | N                     |            |                      |                      |        | X      |                     |             |          |                |              |
| <i>Pyrus calleryana (Not Recommended) ***</i>      | Callary Pear ***            | Only to match existing street trees, Invasive in waterways                       | Decid / Flwer                                   | 15-30' x 10-25'        | M                                     | M   | N                     |            |                      |                      |        |        |                     |             |          |                |              |
| <i>Quercus agrifolia</i>                           | Coast Live Oak              | Needs large planting area, drops acorns  | Evgrn   | 20-70' x 20-70'        | L                                     | M   | Y                     |            |                      |                      |        |        | X                   | X           | X        | X              |              |
| <i>Quercus douglasii</i>                           | Blue Oak                    | Habitat species, difficult to source/establish                                   | Decid   | 20-70' x 20-70'        | L                                     | L   | Y                     |            |                      |                      |        |        |                     |             |          |                |              |
| <i>Quercus engelmannii</i>                         | Engelmann Oak               | Needs large planting area  | Evgrn   | 50-65' x 80-120'       | L                                     | M   | Y                     |            | X                    |                      |        | X      |                     | X           |          |                |              |
| <i>Quercus frainetto 'Schmidt'</i>                 | Hungarian Oak               | Grafted, good symmetry potential   | Decid   | 100' x 70'             | L                                     | L   | N                     |            |                      |                      |        | X      |                     | X           |          |                |              |
| <i>Quercus fusiformis</i>                          | Escarpment (Texas) Live Oak | Similar to Q. Virginiana, more drought tol.                                      | Semi-Deciduous                                  | 20-40' x 20-40'        | L                                     | M   | N                     |            |                      | X                    |        | X      | X                   | X           |          |                |              |
| <i>Quercus hypoleuroides</i>                       | Silverleaf Oak              | Difficult to source, but great tree  | Evgrn   | 30-60' x 20-30'        | L                                     | M   | Y                     |            |                      |                      | X      |        | X                   |             |          | X              |              |

## TREE SPECIES PLANT LIST

| Latin Name  | Common Name          | Comments/ Notes  | Decid / Evgrn /<br>Flwr / Confr /<br>Shrub-like | Mature Size<br>H' X W' | WATER<br>USE<br>WUCOL<br>San<br>Jose* | Salt<br>Tolerance<br>for RCW<br>(H,M,L)** | CA<br>Native<br>(Y/N) | TYPOLOGIES | MAJOR<br>STREETSCAPE | MINOR<br>STREETSCAPE | PASEOS | PLAZAS | PASSIVE GREEN SPACE | PARKING LOT | RIPARIAN | SLOPE - BUFFER | BIORETENTION |
|---|----------------------|--|---|------------------------|---------------------------------------|---|-----------------------|------------|----------------------|----------------------|--------|--------|---------------------|-------------|----------|----------------|--------------|
| <i>Quercus ilex</i> (Not recommended) ***         | Holly Oak ***        | Only to match existing street trees                            | Evgrn   | 30-60' x 30-60'        | L                                     | M   | N                     |            |                      |                      |        |        |                     |             |          |                |              |
| <i>Quercus kelloggii</i>                          | California Black Oak | Local Native, slow growing, difficult to source                | Decid   | 30-70' x 30-50'        | L                                     | M   | Y                     |            |                      |                      |        |        | X                   |             |          | X              |              |
| <i>Quercus lobata</i>                             | Valley Oak           |  | Decid   | 50-70' x 50'           | L                                     | L/M                                       | Y                     |            | X                    |                      |        | X      |                     | X           | X        |                | X            |
| <i>Quercus rugosa</i>                             | Netleaf Oak          |  | Evgrn   | 30-50' x 20-30'        | L                                     | M   | N                     |            | X                    | X                    |        |        |                     | X           |          | X              |              |
| <i>Quercus suber</i>                              | Cork Oak             | Needs large planting area                                      | Evgrn   | 50'-70' x 50' - 70'    | L                                     | M   | N                     |            | X                    | X                    |        | X      |                     | X           |          |                |              |
| <i>Quercus tomentella</i>                         | Island Oak           |  | Evgrn   | 20-50' x 25-40'        | L                                     | L   | Y                     |            |                      | X                    | X      |        | X                   |             |          | X              |              |
| <i>Quercus virginiana</i>                         | Southern Live Oak    | Needs large planting area                                      | Evgrn   | 40-80' x 60-100'       | M                                     | M   | N                     |            |                      |                      |        | X      | X                   | X           |          |                | X            |
| <i>Quercus wislizenii</i>                         | Interior Live Oak    | Difficult to source  | Evgrn   | 30-70' x 40-80'        | L                                     | L   | Y                     |            |                      |                      |        |        |                     |             |          | X              |              |
| <i>Salix laevigata</i>                            | Red Willow           | Habitat value, riparian, can limit visitbility                 | Evgrn-Shrub-like                                | 25-50' x 15-35'        | M                                     | M   | Y                     |            |                      |                      |        |        |                     |             | X        |                |              |
| <i>Salix lasiolepis</i>                           | Arroyo Willow        | Habitat value, riparian, can limit visitbility                 | Evgrn-Shrub-like                                | 10-35'                 | M                                     | M   | Y                     |            |                      |                      |        |        |                     |             | X        |                |              |
| <i>Sambucus nigra ssp. caerulea</i>               | Blue Elderberry      | Habitat value, riparian, can limit visitbility                 | Decid / Flwr                                    | 20 x 20'               | L                                     | M   | Y                     |            |                      |                      |        |        |                     |             | X        | X              | X            |
| <i>Sequoia Sempervirens</i> (Not recommended) *** | Coastal Redwood ***  | High Water Use, use only to match                              | Conifer   | 70-100' x 15-30        | H                                     | L   | Y                     |            |                      |                      |        |        |                     |             |          |                |              |
| <i>Taxodium distichum</i>                         | Bald Cypress         | Use at bottom of bioswales that allow tree                     | Conifer / Decid                                 | 60-80 x 20-30;         | M                                     | L   | N                     |            |                      |                      |        |        |                     |             |          |                | X            |
| <i>Tilia tomentosa 'Sterling'</i>                 | Sterilng Linden      |  | Decid   | 40-50' x 20-30'        | L                                     | M   | N                     |            | X                    | X                    | X      |        |                     |             |          |                |              |
| <i>Tristaniopsis laurina 'Elegant'</i>            | Elegant Water Gum    |  | Evgrn   | 20-35' x 15-25'        | M                                     | M   | N                     |            | X                    | X                    | X      |        |                     | X           |          |                |              |
| <i>Ulmus parvifolia</i>                           | Chinese Elm          | Emer II', Fronteir, Sepmervirens, good fast growing shade tree | Semi-Deciduous                                  | 35-45' x 35-50'        | M                                     | M   | N                     |            |                      |                      |        |        | X                   |             |          |                |              |

## TREE SPECIES PHOTOS: MAJOR STREETS



**AFRICAN FERN PINE**

*Afrocarpus gracilior*  
Water Usage : Low



**MONDELL PINE**

*Pinus eldarica*  
Water Usage : Low



**RED FLOWERING GUM**

*Corymbia ficifolia*  
Water Usage : Low



**ARIZONA ASH**

*Fraxinus velutina*  
Water Usage : Low



**CHINESE FLAME TREE**

*Koelreuteria bipinnata*  
Water Usage : Medium



**SILVER LINDEN**

*Tilia tomentosa*  
Water Usage : Low



**CORK OAK**

*Quercus suber*  
Water Usage : Low



**ENGELMANN OAK**

*Quercus engelmannii*  
Water Usage : Low



**VALLEY OAK**

*Quercus lobata*  
Water Usage : Low

## TREE SPECIES PHOTOS: MINOR STREETS



**PEPPERMINT TREE**  
*Agonis flexuosa*  
Water Usage : Low



**NETLEAF OAK**  
*Quercus rugosa*  
Water Usage : Low



**ISLAND OAK**  
*Quercus tomentella*  
Water Usage : Low



**PINK DAWN CHITALPA**  
*Chitalpa tashkentensis 'Pink Dawn'*  
Water Usage : Low



**AUSTRALIAN WILLOW**  
*Geifera parviflora*  
Water Usage : Low



**AUTUMN GOLD GINKGO**  
*Ginkgo biloba 'Autumn Gold'*  
Water Usage : Low/Medium



**HONEY LOCUST**  
*Gleditsia*  
Water Usage :



**SILVERLEAF OAK**  
*Quercus hypoleucoides*  
Water Usage : Low



**IRON TREE**  
*Metrosideros excelsa*  
Water Usage : Low

## TREE SPECIES PHOTOS: PASEO



**STRAWBERRY TREE**  
*Arbutus unedo* single stem  
Water Usage : Low



**FASTIGATE BLUE ATLAS CEDAR**  
*Cedrus atlantica galuca fastigata*  
Water Usage : Low

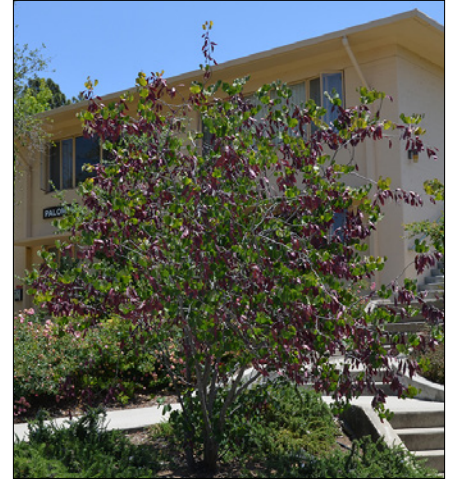

**WESTERN REDBUD**  
*Cercis occidentalis*  
Water Usage : Low



**PALO VERDE**  
*Parkinsonia x 'Desert Museum'*  
Water Usage : Low



**PINK DAWN CHITALPA**  
*Chitalpa tashkentensis 'Pink Dawn'*  
Water Usage : Low



**SWAN HILL OLIVE**  
*Olea europaea 'Swan Hill'*  
Water Usage : Low



**Santa Cruz Island Ironwood**  
*Lyonothamnus floribunda*  
Water Usage : Low



**SILVERLEAF OAK**  
*Quercus hypoleucoides*  
Water Usage : Low

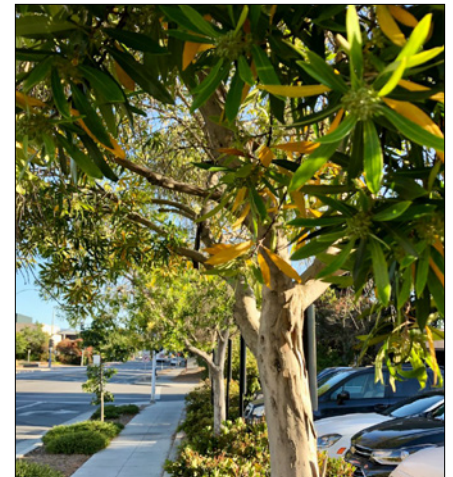

**ELEGANT WATER GUM**  
*Tristaniopsis laurina 'Elegant'*  
Water Usage : Low

## TREE SPECIES PHOTOS: PLAZA



**PALO VERDE**  
*Parkinsonia x 'Desert Museum'*  
Water Usage : Low



**SWAN HILL OLIVE**  
*Olea europea 'Swan Hill'*  
Water Usage : Low



**ENGELMANN OAK**  
*Quercus engelmannii*  
Water Usage : Low



**CORK OAK**  
*Quercus suber*  
Water Usage : Low



**HUNGARIAN OAK**  
*Quercus frainetto 'Schmidt'*  
Water Usage : Low

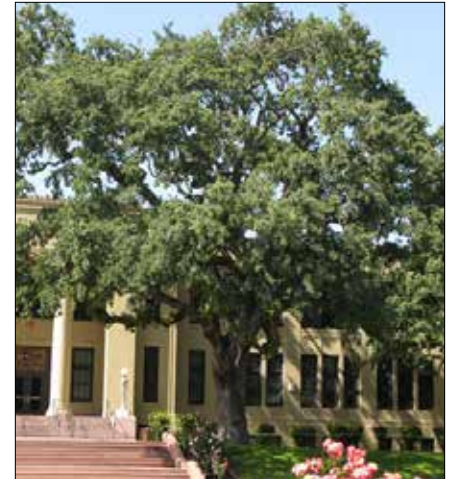

**VALLEY OAK**  
*Quercus lobata*  
Water Usage : Low



**HONEY LOCUST**  
*Gleditsia triacanthos*  
Water Usage : Low



**DRAKE CHINESE ELM**  
*Ulmus parvifolia 'Drake'*  
Water Usage : Medium



**HERITAGE LIVE OAK**  
*Quercus fusiformis*  
Water Usage : Low

# TREE SPECIES PHOTOS: PASSIVE GREEN SPACE



**CALIFORNIA BUCKEYE**

*Aesculus californica*

Water Usage : Low



**MARINA STRAWBERRY TREE**

*Arbutus x 'Marina'*

Water Usage : Low



**DEODAR CEDAR**

*Cedrus deodara*

Water Usage : Low



**PALO VERDE**

*Parkinsonia x 'Desert Museum'*

Water Usage : Low



**ARIZONA CYPRESS**

*Hesperocyparis forbesii*

Water Usage : Low



**HEATH MELALEUCA**

*Melaleuca ericifolia*

Water Usage : Low



**WESTERN REDBUD**

*Cercis occidentalis*

Water Usage : Low



**COAST LIVE OAK**

*Quercus agrifolia*

Water Usage : Low



**CALIFORNIA BLACK OAK**

*Quercus kelloggii*

Water Usage : Low

## TREE SPECIES PHOTOS: PARKING LOTS



**AFRICAN FERN PINE**

*Afrocarpus gracilior*

Water Usage : Low



**PEPPERMINT TREE**

*Agonis flexuosa*

Water Usage : Low



**PINK DAWN CHITALPA**

*Chitalpa tashkentensis 'Pink Dawn'*

Water Usage : Low



**AUSTRALIAN WILLOW**

*Geifera parviflora*

Water Usage : Low



**CHINESE FLAME TREE**

*Koelreuteria bipinnata*

Water Usage : Low



**ARIZONA ASH**

*Fraxinus velutina*

Water Usage : Low



**PALO VERDE**

*Parkinsonia x 'Desert Museum'*

Water Usage : Low



**CORK OAK**

*Quercus suber*

Water Usage : Low



**ENGELMANN OAK**

*Quercus engelmannii*

Water Usage : Low



# TREE SPECIES PHOTOS: BIORETENTION AND BIOSWALES



**BIGLEAF MAPLE**  
*Acer macrophyllum*  
Water Usage : Medium



**WHITE ALDER**  
*Alnus rhombifolia*  
Water Usage : Medium

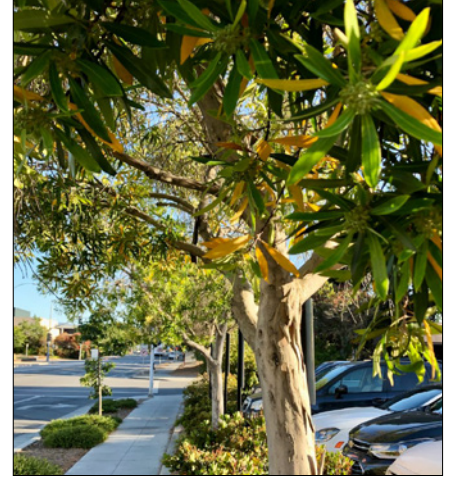

**ELEGANT WATER GUM**  
*Tristaniopsis laurina 'Elegant'*  
Water Usage : Low



**ROBERTS CALIFORNIA SYCAMORE**  
*Plantanus racemosa Roberts*  
Water Usage : Medium



**BAY LAUREL**  
*Laurus nobilis*  
Water Usage : Medium



**VALLEY OAK**  
*Quercus lobata*  
Water Usage : Low



**WESTERN HACKBERRY**  
*Celtis occidentalis*  
Water Usage : Medium



**MARINA STRAWBERRY TREE**  
*Arbutus x Marina*  
Water Usage : Low



**CATALINA CHERRY**  
*Prunus ilicifolia ssp. lyonii*  
Water Usage : Low

## TREE SPECIES PHOTOS: RIPARIAN



**BIGLEAF MAPLE**  
*Acer macrophyllum*  
Water Usage : Medium



**WESTERN REDBUD**  
*Cercis occidentalis*  
Water Usage : Low



**CALIFORNIA BUCKEYE**  
*Aesculus californica*  
Water Usage : Low



**CALIFORNIA SYCAMORE**  
*Plantanus racemosa*  
Water Usage : Medium



**CATALINA CHERRY**  
*Prunus ilicifolia ssp. lyonii*  
Water Usage : Low



**VALLEY OAK**  
*Quercus lobata*  
Water Usage : Low



**BLUE ELDERBERRY**  
*Sambucus nigra ssp. Caerulea*  
Water Usage : Low



**COAST LIVE OAK**  
*Quercus agrifolia*  
Water Usage : Low



**ARROYO WILLOW**  
*Salix lasiolepis*  
Water Usage : Medium/High

# TREE SPECIES PHOTOS: LANDSCAPE BUFFERS / SLOPES



**CALIFORNIA BUCKEYE**  
*Aesculus californica*  
Water Usage : Low



**WESTERN REDBUD**  
*Cercis occidentalis*  
Water Usage : Low



**TECATE CYPRESS**  
*Hesperocyparis forbesii*  
Water Usage : Low



**SANTA CRUZ IRONWOOD**  
*Lyonothamnus floribundus*  
Water Usage : Low



**TORREY PINE**  
*Pinus torreyana*  
Water Usage : Low



**CATALINA CHERRY**  
*Prunus ilicifolia ssp. lyonii*  
Water Usage : Low



**COAST LIVE OAK**  
*Quercus agrifolia*  
Water Usage : Low



**CALIFORNIA BLACK OAK**  
*Quercus kelloggii*  
Water Usage : Low

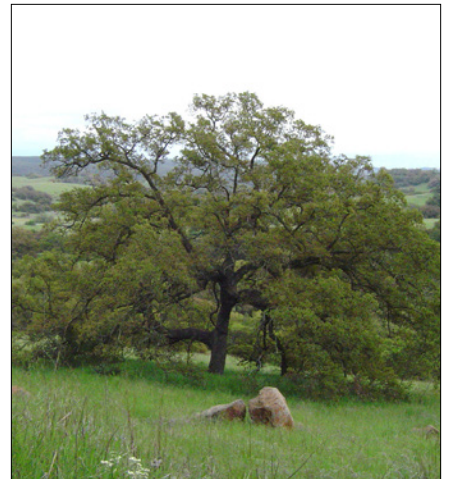

**ENGELMANN OAK**  
*Quercus engelmannii*  
Water Usage : Low

## UNDERSTORY SPECIES PLANT LIST

The following plant list includes understory species recommended for use at TOD projects.

Basic species information is provided. Species have an X in the box for each Landscape Typology for which they are appropriate. California Native Species highlighted in yellow

\* Water Use Information provided by WUCOLS for San Jose, from [https://ucanr.edu/sites/WUCOLS/Plant\\_Search/](https://ucanr.edu/sites/WUCOLS/Plant_Search/)

VL = very low water use L=low water use, M=moderate water use (use sparingly, highlighted in blue), H=high water use (not recommended)

\*\* Salt Tolerance Information as available from varied sources.

H = highly tolerant, M = moderately tolerant, will typically show minimal symptoms, L= not tolerant/ sensitive, will exhibit symptoms

| Latin Name                                   | Common Name              | Plant Type             | Notes  | Mature Size<br>H' X W' | Sun / Shade       | Evrgrn /<br>Decid | WATER<br>USE<br>WUCOLS<br>(San<br>Jose)* | Salt<br>Tolerance<br>for RCW<br>(H,M,L)** | Cali<br>Native<br>(Y/N) | Region of<br>Origin (if not<br>native to<br>Cali) | TYPOLOGIES | MAJOR STREETSCAPE | MINOR STREETSCAPE | PASEOS | PLAZAS | PASSIVE GREEN SPACE | PARKING LOT | RIPARIAN | SLOPE - BUFFER | BIORETENTION |
|--|--------------------------|------------------------|--|------------------------|-------------------|-------------------|--|---|-------------------------|---|------------|-------------------|-------------------|--------|--------|---------------------|-------------|----------|----------------|--------------|
| <i>Abutilon palmeri</i>                      | Indian Mallow            | Perennial Sub-Shrub    | Accent Shrub   | 3'-5' x3'-5'           | Sun               | E                 | L  | M   | Y                       |   |            |                   |                   |        | X      |                     |             |          | X              |              |
| <i>Acacia redolens</i>                       | Prostrate Acacia         | Groundcover - Woody    | Non-Native, but tolerates slopes and no irrigation, Desert Carpet is cultivar                          | 2' x 10-12'            | Sun               | E                 | VL                                       | H   | N                       | Australia   |            |                   |                   |        |        |                     |             |          |                |              |
| <i>Achillea millefolium</i>                  | White Yarrow             | Perennial - herbaceous | Mix with grasses, cultivars Coronation Gold, Paprika, Sonoma Coast, MoonDust,                          | 3' x 3'                | Sun to Part-Shade | D                 | L  | M   | Y                       |   | X          | X                 | X                 |        | X      | X                   | X           |          |                | X            |
| <i>Acmispon glaber</i>                       | Deer Weed                | Perennial Sub-Shrub    | Pioneer species, nitrogen fixer  | 2-3' x 2-3'            | Sun               | E                 | VL                                       | M   | Y                       |   |            |                   |                   |        |        |                     | X           | X        | X              | X            |
| <i>Aeonium spp.</i>                          | Aeonium                  | Succulent              | Specialty Planters   | up to 5' x 5'          |                   | E                 | L  | M   | N                       | South Africa                                      |            |                   |                   | X      | X      |                     |             |          |                |              |
| <i>Agastache rupestris</i>                   | Licorice Mint            | Perennial - herbaceous |  | 3' x 1.5'              | Sun to Part-Shade | D                 | L  | M   | N                       | Southwest US                                      |            |                   |                   |        |        |                     |             |          |                |              |
| <i>Agave attenuata</i>                       | Agave                    | Succulent              |  | 5' x 8'                | Sun               | E                 | L  | M   | N                       | Mexico  |            |                   |                   | X      | X      | X                   |             |          |                |              |
| <i>Agave Blue Glow</i>                       | Blue Glow Century Plant  | Succulent              |  | 2' x 3'                | Sun               | E                 | L  | L   | N                       | Mexico  |            |                   |                   |        | X      | X                   |             |          |                |              |
| <i>Agave spp.</i>                            | Agave                    | Succulent              | Many Agave species and cultivars are listed on SCVWD approved plant list and can be used as            | varies                 | Sun               | E                 | L  | M   | N                       | Mexico  |            |                   |                   |        |        |                     |             |          |                |              |
| <i>Aloe spp.</i>                             | Aloe                     | Succulent              | Many cultivars listed on SCVWD approved plant list and can be used as appropriate i.e. Aloe Vera, Aloe | avg. 3' x 3'           | Sun to Part-Shade | E                 | L  | M   | N                       | South Africa                                      |            |                   | X                 |        | X      |                     |             |          |                |              |
| <i>Anigozanthus spp.</i>                     | Kangaroo Paw             | Perennial              | many cultivars are listed on SCVWD approved plant list Height and color vary.                          | 3' x 4'                | Sun               | E                 | L  | M   | N                       | Australia   |            |                   | X                 | X      | X      | X                   |             |          |                |              |
| <i>Aquilegia formosa</i>                     | Columbine                | Perennial              | Shade only, protected planters   | 3' x 1.5'              | Shade             | D                 | L  | M   | Y                       |   |            |                   | X                 |        | X      |                     |             |          |                |              |
| <i>Arbutus unedo multi-stem</i>              | Strawberry Madrone       | Shrub - tall           | Fruit  | 15' x 15'              | Sun-Part Shade    | E                 | L  | M   | N                       | Mediterranean                                     |            |                   |                   |        |        | X                   |             |          | X              |              |
| <i>Arctostaphylos 'Emerald Carpet'</i>       | Emerald Carpet Manzanita | Groundcover - Woody    | Carmel Sur' or A. uva ursi   | 1.3' x 6'              | Sun to Part-Shade | E                 | L  | M   | Y                       |   | X          |                   |                   |        | X      | X                   |             |          | X              |              |
| <i>Arctostaphylos 'Pacific Mist'</i>         | Pacific Mist Manzanita   | Groundcover - Woody    |  | 2' x 8'                | Sun to Part-Shade | E                 | L  | L   | Y                       |   | X          | X                 |                   |        | X      | X                   |             |          | X              |              |
| <i>Arctostaphylos bakeri 'Louis Edmunds'</i> | Bakers Manzanita         | Shrub - med            |  | 6' x 6'                | Sun               | E                 | L  | L   | Y                       |   |            |                   |                   |        |        |                     |             |          | X              |              |
| <i>Arctostaphylos densiflora</i>             | Vine Hill manzanita      | Shrub - med            | Howard McMinn' or 'Sentinel'   | 3' x 6'                | Sun-Part Shade    | E                 | L  | M   | Y                       |   |            |                   |                   | X      | X      | X                   |             |          | X              |              |
| <i>Arctostaphylos glauca</i>                 | Big Berry Manzanita      | Shrub - tall           |  | 20' x 20'              | Sun               | E                 | L  | M   | Y                       |   |            |                   |                   |        |        |                     |             |          |                |              |

## UNDERSTORY SPECIES PLANT LIST

| Latin Name                               | Common Name            | Plant Type             | Notes   | Mature Size<br>H' X W' | Sun / Shade       | Evrgrn /<br>Decid | WATER<br>USE<br>WUCOLS<br>(San<br>Jose)* | Salt<br>Tolerance<br>for RCW<br>(H,M,L)** | Cali<br>Native<br>(Y/N) | Region of<br>Origin (if not<br>native to<br>Cali) | TYPOLOGIES | MAJOR STREETSCAPE | MINOR STREETSCAPE | PASEOS | PLAZAS | PASSIVE GREEN SPACE | PARKING LOT | RIPARIAN | SLOPE - BUFFER | BIORETENTION |
|--|------------------------|------------------------|---|------------------------|-------------------|-------------------|--|---|-------------------------|---|------------|-------------------|-------------------|--------|--------|---------------------|-------------|----------|----------------|--------------|
| <i>Arctostaphylos hookeri</i>            | Hooker Manzanita       | Shrub - low            |   | 6' x 6'                | Sun to Part-Shade | E                 | L  | M   | Y                       |   |            |                   |                   |        |        |                     |             |          | X              |              |
| <i>Arctostaphylos John Dourley</i>       | John Dourley Manzanita | John Dourley Manzanita | Shrub - Low, spreading, reddish leaves and bark.  | 2' x 6'                | Sun               | E                 | L  | M   | Y                       |   |            |                   |                   |        |        |                     |             |          |                |              |
| <i>Arctostaphylos manzanita</i>          | Manzanita              | Shrub - tall           | Helena' / 'Austin Griffiths' well draining soil   | 20' x 10'              | Sun               | E                 | L  | M   | Y                       |   |            |                   |                   |        |        | X                   |             |          |                |              |
| <i>Arctostaphylos pumila Wavelength'</i> | SandMat Manzanita      | Shrub - med            | Mounding shrub,   | 3' x 15'               | Sun to Part-Shade | E                 | L  | L   | Y                       |   |            |                   |                   |        |        |                     |             |          |                |              |
| <i>Arctostaphylos refugioensis</i>       | Refugio Manzanita      | Shrub - med            |   | 13' x 7'               | Sun               | E                 | L  | M   | Y                       |   |            |                   |                   |        |        |                     |             |          |                |              |
| <i>Arctostaphylos stanfordiana</i>       | Standford Manzanita    | Shrub - med            | Mounding shrub  | 7' x 6'                | Sun               | E                 | L  | M   | Y                       |   |            |                   |                   |        |        |                     |             |          | X              |              |
| <i>Aristida purpurea</i>                 | Purple Three-awn       | Grass                  | Can spread by seed, Warm Season   | 3' x 2'                | Sun               | D                 | L  | M   | Y                       |   |            |                   |                   |        |        |                     |             |          |                |              |
| <i>Aristolochia californica</i>          | Dutchman's Pipe        | Vine                   | Pipevine SwallowTail Host, Excellent climber up Gabions   | 20' x 20'              | Shade             | D                 | N/A                                      | L/M                                       | Y                       |   |            |                   |                   |        |        |                     | X           |          | X              |              |
| <i>Armeria maritima</i>                  | Sea Pink               | Perennial              |   | 1' x 1'                | Part Shade to Sun | E                 | M  | L   | N                       | Mediterranean                                     |            | X                 | X                 | X      |        | X                   |             |          |                |              |
| <i>Artemisia californica</i>             | Sagebrush Prostrate    | Groundcover - Woody    | brown if not irrigated (eg. Berryessa)  | 3-4' x 3-4'            | Sun               | E                 | L  | L   | Y                       |   |            |                   |                   |        | X      |                     |             |          |                | X            |
| <i>Artemisia douglasiana</i>             | Mugwort                | Perennial              | Will take over plantbed   | 3' x 3'                | Sun to Part-Shade | D                 | L  | M   | Y                       |   |            |                   |                   |        |        |                     |             |          |                | X            |
| <i>Asclepias californica</i>             | California Milkweed    | Perennial              | Habitat - Monarch   | 3' x 3'                | Sun               | D                 | L  | H   | Y                       |   |            |                   |                   |        |        |                     |             |          |                | X            |
| <i>Asclepias fascicularis</i>            | Narrow leaf milkweed   | Perennial              | Habitat - Monarch   | 3' x 1'                | Sun               | D                 | L  | M   | Y                       |   |            |                   |                   |        |        |                     |             |          | X              | X            |
| <i>Asclepias speciosa</i>                | Showy Milkweed         | Perennial              | Habitat - Monarch   | 3' x 3'                | Sun               | D                 | L  | M   | Y                       |   |            |                   |                   |        |        |                     |             |          |                | X            |
| <i>Baccharis glutinosa</i>               | Marsh Baccharis        | Perennial              | Salt Marsh Baccharis, only to be planted as part of Bioswale Mix                                    | 6' x 6'                | Sun               | E                 | M  | M   | Y                       |   |            |                   |                   |        |        |                     |             |          |                | X            |
| <i>Baccharis pilularis 'Twin Peaks'</i>  | Dwarf Coyote Bush      | Groundcover - Woody    |   | 3'x12'                 | Sun to Part-Shade | E                 | L  | L   | Y                       |   |            | x                 |                   |        |        |                     | x           |          | x              | x            |
| <i>Baileya multiradiata</i>              | Desert marigold        | Perennial              | Fall blooming yellow flowers  | 1.6' x 1'              | Sun               | D                 | L  | M   | Y                       |   |            |                   |                   |        |        |                     |             |          |                |              |
| <i>Berberis aquifolium var. repens</i>   | Creeping Oregon Grape  | Groundcover -Woody     | Shade   | 2.5' x 5'              | Shade to Part-Sun | D                 | L  | M   | Y                       |   |            |                   |                   | X      |        | X                   |             |          | X              |              |
| <i>Berberis pinnata ssp. Insularis</i>   | California Barberry    | Shrub - med            | Many cultivars have spiny leaves. Blonde Ambition' or straight species. Warm Season, Winter Dormant | 10' x10'               | Shade to Part-Sun | D                 | M  | L   | Y                       |   |            |                   |                   | X      |        | X                   |             |          | X              |              |
| <i>Bouteloua gracilis</i>                | Blue Gramma Grass      | Grass                  | Mix with Native Grasses and In Bioswales  | 1.5' x 2'              | Sun               | D                 | L  | H   | Y                       |   |            | X                 | X                 | X      | X      | X                   | X           |          |                |              |
| <i>Brodiaea californica</i>              | California Brodiaea    | Bulb                   |   | 1.5' - 2' x .5'        | Sun               | D                 | L  | L   | Y                       |   |            |                   |                   |        |        |                     |             |          | X              |              |
| <i>Bromus carinatus</i>                  | California Brome       | Grass                  |   | 1-5' x 1-2'            | S                 | D                 | L  | L   | Y                       |   |            |                   |                   |        |        |                     |             |          |                | X            |
| <i>Bulbine frutescens</i>                | Bulbine                | Succulent              |   | 1.5' x 3'              | Sun to Part-Shade | E                 | L  | M   | N                       | South Africa                                      |            | X                 | X                 |        | X      |                     |             |          |                |              |

## UNDERSTORY SPECIES PLANT LIST

| Latin Name   | Common Name                      | Plant Type         | Notes   | Mature Size<br>H' X W' | Sun / Shade       | Evrgrn /<br>Decid | WATER<br>USE<br>WUCOLS<br>(San<br>Jose)* | Salt<br>Tolerance<br>for RCW<br>(H,M,L)** | Cali<br>Native<br>(Y/N) | Region of<br>Origin (if not<br>native to<br>Cali) | TYPOLOGIES | MAJOR STREETSCAPE | MINOR STREETSCAPE | PASEOS | PLAZAS | PASSIVE GREEN SPACE | PARKING LOT | RIPARIAN | SLOPE - BUFFER | BIORETENTION |
|--|----------------------------------|--------------------|---|------------------------|-------------------|-------------------|--|---|-------------------------|---|------------|-------------------|-------------------|--------|--------|---------------------|-------------|----------|----------------|--------------|
| <i>Calamagrostis nutkaensis</i>                        | Reed Grass                       | Grass              | Larger bunch grass, bottoms of bioswale basins  | 3' x 3'                | Sun to Part-Shade | E                 | M  | M   | Y                       |   |            |                   |                   |        |        |                     | X           |          |                | X            |
| <i>Calochortus luteus</i>                              | Golden Mariposa                  | Bulb               | Specialty Planter under Oaks  | 1' x .5'               | Shade to Part-Sun | D                 | L  | H   | Y                       |   |            |                   |                   |        |        | X                   |             |          | X              |              |
| <i>Calycanthus occidentalis</i>                        | Western Spice Bush               | Shrub - med        | Good for Bioswale Height  | 8' x 20'               | Shade to Part-Sun | D                 | M  | M   | Y                       |   |            |                   |                   | X      |        | X                   |             | X        |                | X            |
| <i>Calylophus drummondiana, berlandieri, Hartwegii</i> | Texas Primrose, Sierra Sundrop   | Perennial          | low groundcover massing   | 2' x 2'                | Sun               | D                 | L  | M   | N                       | Southwest US                                      |            | X                 | X                 | X      | X      | X                   |             |          |                |              |
| <i>Carex barbarae</i>                                  | Santa Barbara Sedge              | Grass              |   | 3' x 3'                | Sun to Part-Shade | E                 | N/A                                      | M   | Y                       |   |            |                   |                   |        |        |                     |             |          |                | X            |
| <i>Carex nudata</i>                                    | Torrent Sedge                    | Grass              |   | 2.5' x 2'              | Sun to Part-Shade | E                 | N/A                                      | H   | Y                       |   |            |                   |                   |        |        |                     |             |          |                | X            |
| <i>Carex pansa</i>                                     | Dune Sedge                       | Grass              |   | 1' x 3'                | Sun to Shade      | E                 | M  | M   | Y                       |   |            | X                 | X                 | X      |        | X                   | X           | X        |                | X            |
| <i>Carex praegracilis</i>                              | Meadow Sedge                     | Grass              |   | 2' x 3'                | Sun to Shade      | E                 | M  | M   | Y                       |   |            | X                 | X                 | X      | X      | X                   | X           |          |                | X            |
| <i>Carex spissa</i>                                    | San Diego Sedge                  | Grass              | Can get very large  | 4' x 4'                | Sun to Part-Shade | E                 | M  | M   | Y                       |   |            |                   |                   |        |        |                     |             |          |                |              |
| <i>Carex tumulicola (C. divulsa)</i>                   | Dwarf Sedge                      | Grass              | Clumping sedge, workes well for bioswale slopes<br>Best in part shade. will have some yellow leaves year-round, but still healthy | 1' x 1-2'              | Shade to Part-Sun | E                 | L  | M   | Y                       |   |            |                   |                   | X      |        | X                   | X           | X        |                | X            |
| <i>Carpenteria californica</i>                         | Bush Anemone                     | Shrub - tall       |   | 8' x 5'                | Shade to Part-Sun | E                 | M  | M   | Y                       |   |            |                   |                   | X      |        | X                   |             |          |                |              |
| <i>Ceanothus 'Ray Hartman'</i>                         | Ray Harmtan California Lilac     | Shrub - tall       |   | 30' x 10'              | Sun               | E                 | L  |   | Y                       |   |            |                   |                   |        |        | X                   |             |          | X              |              |
| <i>Ceanothus maritimus 'Valley Violet'</i>             | Valley Violet Maritime Ceanothus | Shrub - low        |   | 3' x 5'                | Sun to Part-Shade | E                 | L  | M   | Y                       |   |            | X                 | X                 |        | X      | X                   | X           |          | X              |              |
| <i>Ceanothus thyrsiflorus var. griseus</i>             | Carmel Ceanothus                 | Shrub - med        | mounding shrub  | 15' x 15'              | Sun               | E                 | L  | M   | Y                       |   |            |                   |                   |        |        |                     | X           |          | X              |              |
| <i>Ceanothus thysiflorus 'Variety TBD'</i>             | California Lilac                 | Shrub - tall       | Oregon Mist, Concha or other variety  | 15' x 15'              | Sun               | E                 | L  | M   | Y                       |   |            |                   |                   |        |        | X                   |             |          | X              |              |
| <i>Cercocarpus betuloides</i>                          | Mountain Mahogany                | Shrub - tall       | Needs well draining soil  | 20' x 12'              | Sun               | E                 | VL                                       | M   | Y                       |   |            |                   |                   |        |        | X                   |             |          | X              |              |
| <i>Chaenomeles speciosa</i>                            | Flowering Quince                 | Shrub -tall        | Fruiting, Orange flowers in Jan/Feb   | 10' x 12'              |                   | D                 | L  | L   | N                       | Mediterranean                                     |            |                   |                   |        |        | X                   | X           |          | X              |              |
| <i>Chondropetalum elephantium</i>                      | Large Cape Rush                  | Grass              |   | 5' x 10'               | Sun               | E                 | L  | L   | N                       | South Africa                                      |            |                   |                   | X      |        | X                   | X           |          |                |              |
| <i>Chondropetalum tectorum</i>                         | Small Cape Rush                  | Grass              |   | 3' x 3'                | Sun               | E                 | L  | M   | N                       | South Africa                                      |            |                   |                   | X      |        | X                   | X           |          |                |              |
| <i>Cistus ladanifer</i>                                | Rockrose                         | Shrub - med - tall |   | 6' x 5'                | Sun               | E                 | L  | M   | N                       | Mediterranean                                     |            |                   |                   | X      |        | X                   |             |          |                |              |
| <i>Cistus salvifolius prostratus</i>                   | Sageleaf Rockrose                | Groundcover        |   | 2' x 6'                | Sun to Part-Shade | E                 | L  | M   | N                       | Mediterranean                                     |            | X                 | X                 |        | X      | X                   |             |          |                |              |
| <i>Clarkia unguiculata</i>                             | Elegant Clarkia                  | Wildflower         | Annual, C. rubicunda also appropriate   | 3' x 3'                | Sun               | D                 | N/A                                      | M   | Y                       |   |            |                   |                   |        |        |                     |             |          | X              |              |
| <i>Clematis ligustifolia</i>                           | Clematis                         | Vine               | Also C. armandii,   | up to 30' x 6'         | Sun to Part Shade | D                 | M  | L   | Y                       |   |            |                   |                   |        |        |                     |             |          | X              |              |

## UNDERSTORY SPECIES PLANT LIST

| Latin Name                               | Common Name               | Plant Type             | Notes  | Mature Size<br>H' X W' | Sun / Shade       | Evrgrn /<br>Decid | WATER<br>USE<br>WUCOLS<br>(San<br>Jose)* | Salt<br>Tolerance<br>for RCW<br>(H,M,L)** | Cali<br>Native<br>(Y/N) | Region of<br>Origin (if not<br>native to<br>Cali) | TYPLOGIES | MAJOR STREETSCAPE | MINOR STREETSCAPE | PASEOS | PLAZAS | PASSIVE GREEN SPACE | PARKING LOT | RIPARIAN | SLOPE - BUFFER | BIORETENTION |
|--|---------------------------|------------------------|--|------------------------|-------------------|-------------------|--|---|-------------------------|---|-----------|-------------------|-------------------|--------|--------|---------------------|-------------|----------|----------------|--------------|
| <i>Collinsia heterophylla</i>            | Chinese Houses            | Wildflower             | Annual   | 1.6' x 4'              | Shade             | D                 | N/A                                      | M   | Y                       |   |           |                   |                   |        |        |                     |             |          | X              |              |
| <i>Coreopsis grandiflora</i>             | Coreopsis                 | Perennial              |  | 2' x 2'                | Sun               | D                 | M  | L   | Y                       |   |           |                   |                   |        |        | X                   |             |          |                |              |
| <i>Corylus cornuta ssp. Californica</i>  | Hazelnut                  | Shrub -tall            | Small Tree   | 7'-7'                  | Shade             | D                 | M  | M   | Y                       |   |           |                   | X                 | X      |        | X                   |             | X        |                |              |
| <i>Daphne x transatlantica</i>           | Dapne                     | Shrub - med            | Evergreen shrub with white flowers,<br>droupt tolerant | 3' x 3'                | Sun to Part-Shade | E                 | L  | M   | N                       | Asia  |           |                   |                   |        |        |                     |             |          |                |              |
| <i>Dasyliiron wheeleri</i>               | Desert spook              | Succulent              |  | 5' x 5'                | Sun               | E                 | L  | M   | N                       | Soutwest US                                       |           |                   |                   |        | X      | X                   |             |          |                |              |
| <i>Dendromecon hardfordii</i>            | Bush Poppy                | Shrub - med            |  | 15' x 15'              | Sun to Part-Shade | E                 | L  | L   | Y                       |   |           |                   |                   |        |        | X                   |             | X        | X              |              |
| <i>Deschampsia cespitosa</i>             | Tufted Hair Grass         | Grass                  |  | 3' x 3'                | Sun               | D                 | L  | L   | Y                       |   |           |                   |                   |        |        |                     | X           | X        |                | X            |
| <i>Dichelostemma capitatum</i>           | Bluedicks                 | Bulb                   | Mix with Native Grasses and In<br>Bioswales            | 1.5' - 2' x .5'        | Sun               | D                 | VL                                       | M   | Y                       |   |           |                   |                   |        |        |                     |             |          |                | X            |
| <i>Dietes iridoides</i>                  | Fortnight Lily            | Perennial              |  | 2' x 3'                | Sun to Part-Shade | E                 | L  | M   | N                       | South Africa                                      |           | X                 | X                 | X      |        |                     | X           |          |                |              |
| <i>Diplacus aurantiacus</i>              | Bush Monkey Flower        | Perennial Sub-Shrub    |  | 4' x 3'                | Sun to Part-Shade | E                 | L  | M   | Y                       |   |           |                   |                   |        |        |                     |             |          | X              |              |
| <i>Dryopteris arguta</i>                 | Coastal Woodfern          | Fern                   | Under Oaks   | 2' x 2'                | Partial           | E                 | M  | L   | Y                       |   |           |                   |                   |        |        |                     |             |          |                |              |
| <i>Echeveria spp.</i>                    | Hens and Chicks           | Succulent              | Specialty Planters                                     | 0.7' x 0.7'            | Sun               | E                 | L  | M   | N                       | South Africa                                      |           |                   |                   | X      | X      |                     |             |          |                |              |
| <i>Elymus glaucus</i>                    | Blue Wildrye              | Grass                  |  | 5' x 1'                | Sun to Part-Shade | D                 | N/A                                      | M /H                                      | Y                       |   |           |                   |                   |        |        |                     |             |          | X              |              |
| <i>Elymus triticoides</i>                | Creeping Wildrye          | Grass                  | shorter leaves and typically does<br>not flower.       | 4' x 1'                | Sun               | D                 | L  | M /H                                      | Y                       |   |           |                   |                   |        |        |                     | X           |          | X              | X            |
| <i>Encelia Californica</i>               | California Bush Sunflower | Perennial Sub-Shrub    |  | 4x 5'                  | Sun to Part-Shade | D                 | L  | M   | Y                       |   |           |                   |                   |        |        | X                   |             | X        |                |              |
| <i>Epilobium canum</i>                   | California Fuchsia        | Perennial              | Also Epilobium californica                             | 3' x 3'                | Sun to Part-Shade | D                 | L  | M   | Y                       |   |           |                   |                   |        | X      | X                   |             |          | X              |              |
| <i>Ericameria ericoides</i>              |                           | Perennial Sub-Shrub    |  | 3' x 4'                | Sun               | D                 | L  | M /H                                      | Y                       |   |           |                   |                   |        |        |                     |             |          | X              |              |
| <i>Erigeron glaucus 'Wayne Roderick'</i> | Wayne Roderick Daisy      | Perennial - herbaceous |  | 0.5' x 0.7'            | Sun to Part-Shade | E                 | L  | M   | Y                       |   |           |                   |                   |        |        |                     |             |          |                | X            |
| <i>Erigeron karvinskianus</i>            | Santa Barbara Daisy       | Perennial - herbaceous |  | 1-2' x 3-5'            | Shade to Part-Sun | E                 | L  | M   | Y                       |   | X         | X                 | X                 |        | X      | X                   |             |          |                | X            |
| <i>Eriogonum fasciculatum</i>            | California Buckwheat      | Perennial Sub-Shrub    |  | 6' x 3'                | Mon               | E                 | VL                                       | M   | Y                       |   |           |                   |                   |        |        |                     |             |          | X              |              |
| <i>Eriogonum giganteum</i>               | Saint Catherine's Lace    | Perennial Sub-Shrub    |  | 5' x 10'               | Tue               | E                 | L  | M   | Y                       |   |           |                   |                   |        |        |                     |             |          | X              |              |
| <i>Eriogonum grande var. rubescens</i>   | Red-Flowered Buckwheat    | Perennial Sub-Shrub    |  | 1.5' x 3'              | Wed               | E                 | L  | M   | Y                       |   | X         |                   |                   |        |        |                     |             |          |                |              |
| <i>Eriogonum latifolium</i>              | Coast Buckwheat           | Perennial Sub-Shrub    |  | 3' x 3'                | Thu               | E                 | L  | M   | Y                       |   |           |                   |                   |        |        |                     |             |          | X              |              |
| <i>Eriogonum nudum</i>                   | Naked Buckwheat           | Perennial Sub-Shrub    |  | 1' x 0.6'              | Fri               | E                 | L  | M   | Y                       |   | X         |                   |                   |        | X      | X                   | X           |          |                |              |

## UNDERSTORY SPECIES PLANT LIST

| Latin Name   | Common Name           | Plant Type                  | Notes   | Mature Size<br>H' X W' | Sun / Shade       | Evrgrn /<br>Decid | WATER<br>USE<br>WUCOLS<br>(San<br>Jose)* | Salt<br>Tolerance<br>for RCW<br>(H,M,L)** | Cali<br>Native<br>(Y/N) | Region of<br>Origin (if not<br>native to<br>Cali) | TYPLOGIES | MAJOR STREETSCAPE | MINOR STREETSCAPE | PASEOS | PLAZAS | PASSIVE GREEN SPACE | PARKING LOT | RIPARIAN | SLOPE - BUFFER | BIORETENTION |
|--|-----------------------|-----------------------------|---|------------------------|-------------------|-------------------|--|---|-------------------------|---|-----------|-------------------|-------------------|--------|--------|---------------------|-------------|----------|----------------|--------------|
| <i>Eriogonum umbellatum</i>                              | Sulfur Buckwheat      | Perennial Sub-Shrub         |   | 2' x 1'                | Sat               | E                 | L  | M   | Y                       |   |           | X                 |                   |        |        | X                   | X           | X        | X              |              |
| <i>Escholzia californica</i>                             | California Poppy      | Wildflower                  | Annual  | 1' x 1'                | Sun               | D                 | VL                                       | M   | Y                       |   |           |                   |                   |        |        |                     | X           |          | X              | X            |
| <i>Euthamia occidentalis</i>                             | Western Goldentop     | Perennial - herbaceous      | Salt tolerant   | 2-5' x 2-6'            | Sun               | D                 | N/A                                      | H   | Y                       |   |           |                   |                   |        |        |                     |             | X        | X              | X            |
| <i>Fallugia paradoxa</i>                                 | Apache Plume          | Perennial Sub-Shrub         |   | 4' x 4'                | Sun               | D                 | L  | H   | Y                       |   |           |                   |                   |        |        | X                   |             |          | X              |              |
| <i>Feijoa sellowiana</i>                                 | Pinapple Guava        | Shrub - tall                |   | 15' x 15'              | Sun               | E                 | N/A                                      | M   | N                       | Mediterranean                                     |           |                   |                   |        | X      | X                   |             |          |                |              |
| <i>Festuca californica</i>                               | California Fescue     | Grass                       | Salt tolerant   | 3' x 2'                | Sun to Shade      | D                 | L  | M   | Y                       |   |           |                   |                   |        |        |                     |             |          | X              |              |
| <i>Festuca idahoensis</i> 'Tomales Bay'<br>(Elijah Blue) | Fescue Bunchgrass     | Grass                       |   | 1.5' x 1.5'            | Part Shade to Sun | D                 | VL                                       | M   | Y                       |   | X         | X                 | X                 | X      | X      |                     |             |          |                |              |
| <i>Festuca rubra</i>                                     | Red Fescue            | Grass                       |   | 0.5' x 2'              | Part Shade to Sun | D                 | L  | L   | Y                       |   |           |                   |                   |        |        |                     |             |          | X              | X            |
| <i>Ficus pumila</i>                                      | Creeping Fig          | Vine                        | sparingly as screen plant where<br>needed.            | 15' x 6'               | Sun               | E                 | M  | M   | N                       | Asia  |           |                   |                   |        |        |                     |             |          |                |              |
| <i>Fragaria chiloensis</i>                               | Beach Strawberry      | Groundcover -<br>Herbaceous |   | 1' x 3'                | Sun to Shade      | E                 | M  | M   | Y                       |   |           |                   |                   |        |        |                     |             |          | X              |              |
| <i>Fragaria vesca</i>                                    | Mountain Strawberry   | Groundcover -<br>Herbaceous |   | 0.8' x 1.5'            | Shade to Part-Sun | E                 | M  | M   | Y                       |   |           |                   |                   |        |        |                     |             |          | X              |              |
| <i>Fremontodendron californica</i>                       | Flannel Bush          | Shrub - tall                |   | 20' x 20'              | Sun               | D                 | VL                                       | M/H                                       | Y                       |   |           |                   |                   |        |        | X                   |             | X        | X              |              |
| <i>Gaillardia grandiflora</i>                            | Blanket Flower        | Perennial - herbaceous      |   | 2' x 1.2'              | Sun               | E                 | L  | M/H                                       | N                       | Texas   | X         |                   |                   |        |        |                     |             |          |                |              |
| <i>Garrya elliptica</i>                                  | Evie Silk Tassel Bush | Shrub - tall                | 'Evie', Garrya fremontii is another<br>native species | 10' x 10'              | Sun               | E                 | L  | M   | Y                       |   |           |                   |                   |        |        |                     |             |          | X              |              |
| <i>Gaura lindheimeri</i>                                 | Gaura                 | Perennial - herbaceous      |   | 2' x 2'                | Sun               | D                 | M  | M   | N                       | Mediterranean                                     |           | X                 |                   |        | X      | X                   |             |          |                |              |
| <i>Geranium sanguineum</i>                               | Cranesbill            | Groundcover                 |   | 1' x 2'                | Shade             | D                 | M  | L   | N                       | Mediterranean                                     |           |                   | X                 |        | X      |                     |             |          |                |              |
| <i>Gilia capita</i>                                      | Gumplant              | Wildflower                  | Annual  | 2' x 2'                | Sun               | D                 | L  | M   | Y                       |   |           |                   |                   |        |        |                     |             |          | X              |              |
| <i>Grevelia 'Moonlight' or other<br/>variety</i>         |                       | Shrub - med                 |   | 12' x 8'               | Sun to Part-Shade | E                 | L  | M/H                                       | N                       | Australia   |           | X                 |                   |        | X      | X                   |             |          |                |              |
| <i>Grindelia stricta platyphylla</i>                     | Coastal Gum Plant     | Perennial - herbaceous      | Salt tolerant   | 2' x 4'                | Sun               | D                 | L  | H   | Y                       |   |           |                   |                   |        |        |                     |             |          | X              | X            |
| <i>Helianthemum nummularium</i><br>'Henfield Brilliant'  | Sunrose               | Grouncover                  |   | 0.7' x 2'              | Part Shade to Sun | E                 | L  | H   | N                       | Mediterranean                                     |           | X                 | X                 |        |        |                     |             |          |                |              |
| <i>Helianthus californicus</i>                           | California Sunflower  | Wildflower                  | Salt tolerant   | 5' x 10'               | Sun               | D                 | L  | M   | Y                       |   |           |                   |                   |        | X      |                     |             |          | X              |              |
| <i>Helictotrichon sempervirens</i>                       | Blue Oat Grass        | Grass                       |   | 2' x 3'                | Sun               | D                 | L  | M   | Y                       |   |           |                   |                   |        |        |                     |             |          | X              | X            |
| <i>Hesperaloe pavifolia</i>                              | Red Yucca             | grass                       |   | 4' x 6'                | Sun               | E                 | L  | M/H                                       | Y                       |   |           |                   |                   |        | X      | X                   | X           |          |                |              |
| <i>Hesperoyucca whipplei</i>                             | Chaparral Yucca       | Succulent                   |   | 9' x 9'                | Sun               | E                 | L  | M/H                                       | N                       | South Africa                                      |           |                   |                   |        | X      | X                   |             |          | X              |              |



## UNDERSTORY SPECIES PLANT LIST

| Latin Name                                 | Common Name              | Plant Type             | Notes  | Mature Size<br>H' X W' | Sun / Shade       | Evrgrn /<br>Decid | WATER<br>USE<br>WUCOLS<br>(San<br>Jose)* | Salt<br>Tolerance<br>for RCW<br>(H,M,L)** | Cali<br>Native<br>(Y/N) | Region of<br>Origin (if not<br>native to<br>Cali) | TYPOLOGIES | MAJOR STREETSCAPE | MINOR STREETSCAPE | PASEOS | PLAZAS | PASSIVE GREEN SPACE | PARKING LOT | RIPARIAN | SLOPE - BUFFER | BIORETENTION |
|--|--------------------------|------------------------|--|------------------------|-------------------|-------------------|--|---|-------------------------|---|------------|-------------------|-------------------|--------|--------|---------------------|-------------|----------|----------------|--------------|
| <i>Heteromeles arbutifolia</i>             | Toyon                    | Shrub - tall           |  | 10' x 8'               | Sun to Part-Shade | E                 | L  | M   | Y                       |   |            |                   |                   |        |        | X                   |             | X        | X              |              |
| <i>Heuchera maxima</i>                     | Island Alumroot          | Perennial              |  | 3' x 2'                | Shade to Part-Sun | E                 | M  | L   | Y                       |   |            |                   | X                 | X      | X      |                     |             |          | X              |              |
| <i>Heuchera micrantha</i>                  | Crevice Alumroot         | Perennial - herbaceous |  | 1-3' x 1'              | Shade             | E                 | M  | L   | Y                       |   |            |                   |                   |        |        |                     |             |          |                |              |
| <i>Holodiscus discolor</i>                 | Creambush                | Shrub - med            |  | 9' x 6'                | Shade             | E                 | L  | M   | Y                       |   |            |                   |                   |        |        | X                   |             |          | X              |              |
| <i>Hordeum brachyantherum</i>              | Meadow Barley            | Grass                  |  | 2' x 1'                | Sun to Part-Shade | D                 | N/A                                      | M   | Y                       |   |            |                   |                   |        |        |                     |             |          |                | X            |
| <i>Iris 'Canyon Snow'</i>                  | Canyon Snow Pacific Iris | Perennial              |  | 1.5' x 3'              | Shade to Part-Sun | E                 | L  | L   | Y                       |   | X          | X                 | X                 |        |        | X                   |             |          |                |              |
| <i>Iris douglasiana</i>                    | Douglas Iris             | Perennial              |  | 2' x 4'                | Shade to Part-Sun | E                 | L  | L   | Y                       |   |            |                   |                   |        |        |                     |             |          |                | X            |
| <i>Ixia spp.</i>                           | African Corn Lily        | Bulb                   |  | 1' x 1'                | Sun to Part Shade | D                 | N/A                                      | M   | N                       | South Africa                                      | X          | X                 | X                 | X      |        |                     |             |          |                |              |
| <i>Jasmine nudiflorum</i>                  | Winter Jasmine           | Vine                   |  | 12' x 4'               | Sun to Part Shade | D                 | L  | L   | N                       | Asia  |            |                   | X                 | X      | X      |                     |             |          |                |              |
| <i>Jasmine officiale f. grandiflorum</i>   | Common Jasmine           | Vine                   |  | 4' x 7'                | Sun to Part Shade | D                 | L  | L   | N                       | Asia  |            |                   | X                 |        | X      |                     |             |          |                |              |
| <i>Juncus effusus</i>                      | Green Rush               | Grass                  |  | 4' x 1.5'              | Sun               | E                 | M  | M   | Y                       |   |            |                   |                   |        |        |                     |             |          |                | X            |
| <i>Juncus patens</i>                       | Common Rush              | Grass                  |  | 3' x 2'                | Sun               | E                 | L  | M   | Y                       |   |            |                   |                   |        |        |                     |             |          |                | X            |
| <i>Keckiella cordifolia</i>                | Red Hot Pokers           | Shrub - low            | Under Oaks                                   | 6' x 6'                | Shade             | D                 | L  | M   | Y                       |   |            |                   |                   |        |        | X                   |             |          | X              |              |
| <i>Kniphofia uvaria hybrids</i>            | Red Hot Poker            | Succulent              | Prefers some fog                             | 3' x 3'                | Sun to Part Shade | E                 | L  | M/H                                       | N                       | South Africa                                      |            |                   | X                 | X      | X      |                     |             |          |                |              |
| <i>Lavandula spp. 'Goodwin Creek Grey'</i> | Lavender                 | Perennial Sub-Shrub    |  | 3' x 4'                | Sun to Part-Shade | E                 | L  | M   | N                       | Mediterranean                                     |            | X                 |                   | X      | X      |                     |             |          |                |              |
| <i>Lavandula stoechas 'Otto Quast'</i>     | Spanish Lavender         | Perennial Sub-Shrub    |  | 3' x 3'                | Sun to Part-Shade | E                 | L  | M   | N                       | Mediterranean                                     |            | X                 |                   | X      | X      |                     |             |          |                |              |
| <i>Lavatera maritima</i>                   | Bush Mallow              | Perennial Sub-Shrub    |  | 8' x 12'               | Sun to Part-Shade | D                 | L  | M/H                                       | Y                       |   |            |                   |                   |        |        |                     |             |          |                | X            |
| <i>Lepechinia calycina</i>                 | Pitcher Sage             | Perennial Sub-Shrub    |  | 8' x 6'                | Shade             | D                 | L  | L   | Y                       |   |            |                   | X                 | X      | X      |                     |             |          |                |              |
| <i>Lessingia felaginifolia</i>             | California Dune Aster    | Groundcover/Annual     |  | 0.3' x 8'              | Sun to Part-Shade | E                 | L  | M   | Y                       |   |            |                   |                   |        | X      |                     |             |          | X              |              |
| <i>Leucojum aestivum</i>                   | Summer Snowflake         | Bulb                   | Can add to streetscapes to enhance diversity | 1.5' - 2' x .5'        | Sun               | D                 | M  | L   | N                       | Mediterranean                                     |            | X                 | X                 |        | X      |                     |             |          |                |              |
| <i>Leymus condensatus 'Canyon Prince'</i>  | Canyon Prince Wild Rye   | Groundcover            |  | 4' x 4'                | Sun to Part-Shade | E                 | L  | M/H                                       | Y                       |   |            |                   |                   |        |        |                     | X           |          | X              | X            |
| <i>Limonium perezii</i>                    | Statice                  | Perennial              |  | 3' x 3'                | Sun to Part-Shade | E                 | L  | M/H                                       | N                       | Mediterranean                                     | X          | X                 | X                 |        |        |                     |             |          |                |              |
| <i>Lonicera hispidula</i>                  | California Honeysuckle   | Vine                   |  | 18' x 10'              | Sun to Part Shade | D                 | L  | M   | Y                       |   |            |                   | X                 |        | X      |                     |             | X        | X              |              |
| <i>Lupinus albifrons</i>                   | Silver Bush Lupine       | Perennial Sub-Shrub    |  | 2' x 5'                | Sun               | D                 | VL                                       | M   | Y                       |   |            |                   |                   |        | X      |                     |             |          | X              |              |

## UNDERSTORY SPECIES PLANT LIST

| Latin Name                                    | Common Name             | Plant Type               | Notes  | Mature Size<br>H' X W' | Sun / Shade       | Evrgrn /<br>Decid | WATER<br>USE<br>WUCOLS<br>(San<br>Jose)* | Salt<br>Tolerance<br>for RCW<br>(H,M,L)** | Cali<br>Native<br>(Y/N) | Region of<br>Origin (if not<br>native to<br>Cali) | TYPOLOGIES | MAJOR STREETSCAPE | MINOR STREETSCAPE | PASEOS | PLAZAS | PASSIVE GREEN SPACE | PARKING LOT | RIPARIAN | SLOPE - BUFFER | BIORETENTION |
|---|-------------------------|--------------------------|--|------------------------|-------------------|-------------------|--|---|-------------------------|---|------------|-------------------|-------------------|--------|--------|---------------------|-------------|----------|----------------|--------------|
| <i>Malacothamnus fasciculatus</i>             | Bush Mallow             | Perennial Sub-Shrub      |  | 15' x 10'              | Sun               | E                 | VL                                       | M   | Y                       |   |            |                   |                   |        | X      | X                   |             |          | X              |              |
| <i>Melaleuca armillaris</i>                   | Bracelet Honey-Myrtle   | Shrub - tall             |  | 15-30' x 15-30'        | Sun               | E                 | VL                                       | M/H                                       | N                       | Australia   |            |                   |                   |        |        | X                   |             |          |                |              |
| <i>Melaleuca decussata</i>                    | Totem Poles             | Shrub - tall             |  | 8-2'- x 8-20'          | Sun               | E                 | VL                                       | M/H                                       | N                       | Australia   |            |                   |                   |        |        | X                   |             |          |                |              |
| <i>Melica imperfecta</i>                      | Coast Range Onion Grass | Grass                    |  | 1-3' x 2-3'            | Sun               | D                 | VL                                       | M   | Y                       |   |            |                   |                   |        |        |                     |             | X        | X              | X            |
| <i>Monardella villosa</i>                     | Coyote Mint             | Perennial                |  | 1.5' x 3'              | Sun to Shade      | D                 | VL                                       | M   | Y                       |   |            |                   |                   |        |        |                     |             | X        |                |              |
| <i>Muhlenbergia capillaris</i>                | Pink Muhly Grass        | Grass                    |  | 4' x 3'                | Sun               | E                 | L  | M   | N                       | Eastern US  |            |                   |                   |        |        |                     |             |          |                | X            |
| <i>Muhlenbergia dubia</i>                     | Pine Muhly Grass        | Grass                    |  | 3' x 4'                | Sun               | E                 | L  | M   | N                       | Southwest US                                      |            | X                 | X                 |        |        | X                   | X           |          | X              | X            |
| <i>Muhlenbergia rigens</i>                    | Deergrass               | Grass                    |  | 4-5' x 4-6'            | Sun               | E                 | L  | M   | Y                       |   |            |                   |                   |        | X      | X                   | X           |          |                | X            |
| <i>Myoporum parvifolium</i>                   | Myoporum                | Groundcover/Shurb        |  | 1' x 10'               | Sun               | E                 | L  | M   | N                       | Australia   |            |                   |                   |        |        |                     |             |          |                |              |
| <i>Myrtus communis compacta</i>               | Dwarf Myrtle            | Shrub - med              | hedge  | 2-4' x 2-4'            | Sun               | E                 | L  | M   | N                       | Australia   |            |                   |                   | X      | X      |                     | X           |          |                |              |
| <i>Nolina microcarpa</i>                      | Bear Grass              | Grass                    | Also N. nelsonii                             | 5' x 7'                | Sun               | E                 | VL                                       | M/H                                       | Y                       |   |            |                   |                   |        |        |                     |             |          |                |              |
| <i>Olea europea 'Little Ollie'</i>            | Dwarf Olive             | Shrub - Med              |  | 6' x 6'                | Sun to Part-Shade | E                 | VL                                       | M   | N                       | Mediterranean                                     |            |                   |                   | X      | X      | X                   | X           |          |                |              |
| <i>Origanum dictamnus and other species</i>   | Oreganos                | Perennial/Annual         |  | 1' x 3'                | Part Shade to Sun | E                 | M  | L   | N                       | Mediterranean                                     |            |                   | X                 |        |        |                     |             |          |                |              |
| <i>Oxalis oregana</i>                         | Redwood Sorrel          | Groundcover              |  | 1.3' x 6'              | Shade             | D                 | M  | L   | Y                       |   |            |                   |                   |        |        | X                   |             |          |                |              |
| <i>Parthenocissus tricuspidata</i>            | Virginia Creeper        | Vine                     | Can use P. vitaveae or P. henryaba as well   | up to 50' x 10'        | Sun to Part Shade | D                 | L  | M   | N                       | North America                                     |            |                   |                   | X      |        |                     |             |          |                |              |
| <i>Penstemon centranthifolius</i>             | Scarlet Bugler          | Perennial                |  | 3' x 2'                | Sun               | D                 | N/A                                      | M   | Y                       |   |            |                   |                   |        |        |                     |             |          |                | X            |
| <i>Penstemon heterophyllus 'Blue Springs'</i> | Foothill Penstemon      | Perennial                |  | 2' x 1.5'              | Sun               | D                 | N/A                                      | M   | Y                       |   |            |                   | X                 |        | X      | X                   | X           |          | X              |              |
| <i>Phacelia californica</i>                   | Scorpion Flower         | Wildflower               | Slopes and Under Oaks, Good Habitat          | 1' x 1.5'              | Sun to Part Shade | D                 | L  | M   | Y                       |   |            |                   |                   |        |        |                     |             |          | X              |              |
| <i>Phlomis lanata</i>                         | Jerusalem Sage          | Perennial Sub-Shrub      |  | 2' x 6'                | Sun               | E                 | L  | M   | N                       | Mediterranean                                     |            |                   | X                 | X      | X      | X                   |             |          |                |              |
| <i>Phormium tenax</i>                         | New Zealand Flax        | Perennial                | ?  | 2' x 3'                | Sun               | E                 | L  | M/H                                       | N                       | New Zealand                                       |            |                   |                   | X      |        | X                   | X           |          |                |              |
| <i>Phylla nodiflora</i>                       | Lippia                  | Groundcover - herbaceous |  | 0.4' x 2'              | Sun to Part-Shade | E                 | N/A                                      | M   | N                       | Mediterranean                                     |            |                   |                   |        |        |                     | X           |          |                |              |
| <i>Physocarpus capitatus</i>                  | Ninebark                | Shrub - tall             |  | 13' x 7'               | Shade to Part-Sun | D                 | L  | L   | Y                       |   |            |                   |                   |        |        |                     |             |          | X              |              |
| <i>Podocarpus henkelii</i>                    | Long Leafed Yellowwood  | Shrub - tall             |  | 30' x 25'              | Sun to Part-Shade | E                 | M  | L   | N                       | Asia  |            |                   |                   | X      | X      | X                   |             |          |                |              |
| <i>Polypodium californicum</i>                | Polypody Fern           | Fern                     | Under Oaks, P. scouleri is also good species | 1' x 1'                | Shade to Part-Sun | E                 | VL                                       | L   | Y                       |   |            |                   |                   | X      |        |                     |             |          | X              |              |

## UNDERSTORY SPECIES PLANT LIST

| Latin Name   | Common Name            | Plant Type                           | Notes   | Mature Size<br>H' X W' | Sun / Shade       | Evrgrn /<br>Decid | WATER<br>USE<br>WUCOLS<br>(San<br>Jose)* | Salt<br>Tolerance<br>for RCW<br>(H,M,L)** | Cali<br>Native<br>(Y/N) | Region of<br>Origin (if not<br>native to<br>Cali) | TYPOLOGIES | MAJOR STREETSCAPE | MINOR STREETSCAPE | PASEOS | PLAZAS | PASSIVE GREEN SPACE | PARKING LOT | RIPARIAN | SLOPE - BUFFER | BIORETENTION |
|--|------------------------|--------------------------------------|---|------------------------|-------------------|-------------------|--|---|-------------------------|---|------------|-------------------|-------------------|--------|--------|---------------------|-------------|----------|----------------|--------------|
| <i>Polystichum munitum</i>                               | Western Sword Fern     | Fern                                 | Under Oaks  | 2' x 2'                | Shade             | E                 | M  | L   | Y                       |   |            |                   |                   | X      | X      | X                   |             |          |                |              |
| <i>Prunus ilicifolia</i>                                 | Holly Leaf Cherry      | Shrub-tall                           |   | 30' x 25'              | Sun to Part-Shade | E                 | L  | L   | Y                       |   |            |                   |                   |        |        |                     |             |          |                |              |
| <i>Quercus berberidifolia</i>                            | Scrub Oak              | Shrub - tall                         | Available at native plant nurseries,<br>plant small | 15' x 12'              | Sun to Part-Shade | E                 | VL                                       | M   | Y                       |   |            |                   |                   |        |        |                     |             | X        | X              |              |
| <i>Quercus durata</i>                                    | Leather Oak            | Shrub - tall                         | Available at native plant nurseries,<br>plant small | 9' x 6'                | Sun to Part-Shade | E                 | VL                                       | M   | Y                       |   |            |                   |                   |        |        |                     |             | X        | X              |              |
| <i>Ranunculus californicus</i>                           | California Buttercup   | Herbaceous                           | Small, Can be added to Carex's in<br>Bioswales      | 3' x 3'                | Sun to Part-Shade | D                 | VL                                       | M   | Y                       |   |            |                   |                   |        |        |                     |             |          |                | X            |
| <i>Rhamnus californica</i>                               | Coffeeberry            | Shrub - med - tall                   | Eve Case', Mound San Bruno,<br>Leather leaf,        | 3-6' x 3-65'           | Sun to Part-Shade | E                 | L  | M   | Y                       |   |            |                   |                   | X      |        | X                   | X           | X        | X              |              |
| <i>Rhus integrifolia (ovata)</i>                         | Lemonadeberry          | Shrub - tall                         |   | 25' x 25'              | Sun               | E                 | L  | M   | Y                       |   |            |                   |                   |        |        |                     | X           |          | X              |              |
| <i>Ribes aureum</i>                                      | Golden Currant         | Shrub - tall                         |   | 3.5' x 3.5'            | Shade             | D                 | N/A                                      | L   | Y                       |   |            |                   |                   |        |        | X                   |             | X        | X              |              |
| <i>Ribes malvaceum</i>                                   | Chaparral Currant      | Shrub - tall                         |   | 6' x 6'                | Shade             | D                 | VL                                       | L   | Y                       |   |            |                   |                   |        |        | X                   |             | X        | X              |              |
| <i>Ribes sanguineum glutinosum</i>                       | Pink -Flowered Currant | Shrub - tall upright                 | moderate maintenance                                | 12' x 12'              | Sun to Part-Shade | D                 | L  | L   | Y                       |   |            |                   |                   | X      |        | X                   |             | X        | X              |              |
| <i>Ribes viburnifolium</i>                               | Evergreen Currant      | Shrub - low                          |   | 4' x 6'                | Shade to Part-Sun | E                 | L  | M   | Y                       |   |            |                   | X                 | X      |        | X                   |             |          |                | X            |
| <i>Rosa californica</i>                                  | California Wild Rose   | Shrub                                | Spreads !   | 3' x 9'                | Sun to Part-Shade | E                 | L  | M   | Y                       |   |            |                   |                   |        |        |                     |             | X        | X              |              |
| <i>Rosemarinus officinalis<br/>'Huntington's Carpet'</i> | Creeping Rosemary      | Groundcover - Woody                  | Mediterranean, Drought Tolerant,<br>Low Maintenance | 1.5' x 1.5'            | Sun to Part-Shade | E                 | L  | M   | N                       | Mediterranean                                     |            | X                 | X                 |        |        | X                   | X           |          | X              |              |
| <i>Rosmarinus officinalis 'Tuscan<br/>Blue'</i>          | Rosemary               | Shrub - med                          | Count   | 4' x 2'                | Sun to Part-Shade | E                 | L  | M   | N                       | Mediterranean                                     |            |                   | X                 |        |        | X                   | X           |          | X              |              |
| <i>Rubus parviflorus</i>                                 | Thimbleberry           | Vine - Shrub                         | Can be invasive                                     | 8' x 6'                | Sun to Part Shade | D                 | L  | M   | Y                       |   |            |                   |                   |        |        |                     |             |          |                | X            |
| <i>Salvia apiana</i>                                     | White Sage             | Perennial Sub-Shrub                  |   | 4.5' x 4.5'            | Sun               | D                 | VL                                       | M   | Y                       |   |            |                   |                   |        |        | X                   |             |          |                | X            |
| <i>Salvia clevelandii</i>                                | Cleveland Sage         | Perennial Sub-Shrub                  |   | 4.5' x 4.5'            | Sun to Part-Shade | E                 | L  | M   | Y                       |   |            |                   |                   |        |        | X                   | X           |          |                |              |
| <i>Salvia greggii</i>                                    | Autumn Sage            | Perennial Sub-Shrub                  |   | 3' x 3'                | Sun to Part-Shade | E                 | L  | M/H                                       | N                       | Mexico  |            |                   | X                 | X      | X      |                     |             |          |                |              |
| <i>Salvia leucophylla 'Bee's Bliss'</i>                  | Bee's Bliss Sage       | Groundcover Shrub                    |   | 2' x 8'                | Sun               | E                 | L  | M   | Y                       |   |            | X                 |                   |        |        |                     | X           |          | X              |              |
| <i>Salvia spathacea</i>                                  | Hummingbird Sage       | Groundcover Perennial                |   | 2' x 5'                | Shade to Part-Sun | E                 | L  | M   | Y                       |   |            |                   | X                 | X      |        | X                   |             |          |                | X            |
| <i>Santolina chamaecyparissus</i>                        | Dwarf Lavender Cotton  | Perennial - herbaceous               |   | 2' x 4'                | Sun               | E                 | L  | H   | N                       | Mediterranean                                     |            | X                 |                   |        |        |                     |             |          |                |              |
| <i>Satureja douglasii</i>                                | Yerba Buena            | Perennial                            |   | 0.5' x 0.5'            | Shade to Part-Sun | E                 | L  | M   | Y                       |   |            |                   |                   |        |        |                     |             |          |                | X            |
| <i>Scrophularia californica</i>                          | Bee Plant              | Perennial Sub-Shrub                  |   | 4' x 12'               | Partial           | D                 | L  | L   | Y                       |   |            |                   |                   |        |        |                     |             |          |                | X            |
| <i>Sedum spp.</i>  | Stonecrop              | Groundcover Succulent -<br>spreading |   | up to 3' x 3'          | Sun to Part-Shade | E                 | L  | M   | N                       | Mediterranean                                     |            |                   |                   |        |        |                     |             |          |                |              |

# UNDERSTORY SPECIES PHOTOS: MAJOR STREETS

## SHRUBS



VALLEY VIOLET MARITIME  
CEANOTHUS  
*Ceanothus maritimus* 'Valley Violet'



EMERALD CARPET  
MANZANITA  
*Arctostaphylos*  
'Emerald Carpet'



PACIFIC MIST MANZANITA  
*Arctostaphylos*  
'Pacific Mist'



DWARF COYOTE BUSH  
*Baccharis pilularis*  
'Twin Peaks'



SAGELEAF ROCKROSE  
*Cistus salvifolius prostratus*

## GRASSES



MOOR GRASS  
*Sesleria autumnalis*



DUNE SEDGE  
*Carex pansa*



MEADOW SEDGE  
*Carex praegracilis*



PINE MUHLY GRASS  
*Muhlenbergia dubia*



Elijah Blue Fescue  
*Festuca glauca* 'Elijah Blue'

## FLOWERING PERENNIALS



WHITE YARROW  
*Achillea millefolium*



FORTNIGHT LILY  
*Dietes iridoides*



NAKED BUCKWHEAT  
*Eriogonum nudum*

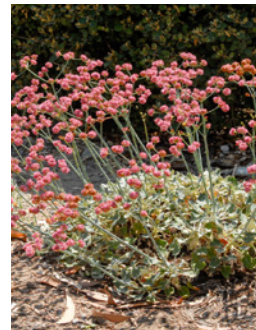

RED-FLOWERED  
BUCKWHEAT  
*Eriogonum grande*  
var. *rubescens*

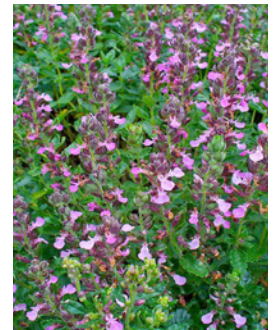

Wall Germander  
*Teucrium chamaedrys*

## FLOWERING PERENNIALS



BLANKET FLOWER  
*Gaillardia grandiflora*

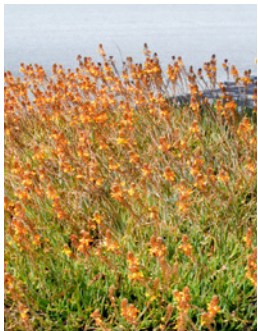

STALKED BULBINE  
*Bulbine frutescens*



DWARF LAVENDER COTTON  
*Santolina chamaecyparissus*

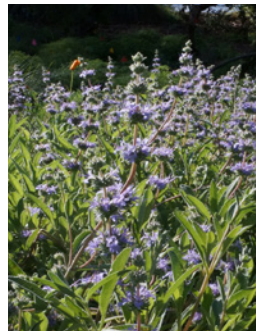

CREEPING SAGE  
*Salvia leucophylla*  
'Bee's Bliss'



BLUE-EYED GRASS  
*Syrinchium bellum*

# UNDERSTORY SPECIES PHOTOS: MINOR STREETS

## LOW SHRUBS/GROUNDCOVERS



EVERGREEN CURRANT  
*Ribes Viburnifolium*



PACIFIC MIST MANZANITA  
*Arctostaphylos*  
'Pacific Mist'



VALLEY VIOLET MARITIME  
CEANOTHUS  
*Ceanothus maritimus* 'Valley  
Violet'



TRAILING ROSEMARY  
*Rosmarinus officinalis*



COYOTE BUSH  
*Baccharis pilularis* 'Pigeon  
Point'

## GRASSES



MOOR GRASS  
*Sesleria autumnalis*



DUNE SEDGE  
*Carex pansa*



MEADOW SEDGE  
*Carex praegracilis*



PINE MUHLY GRASS  
*Muhlenbergia dubia*



Elijah Blue Fescue  
*Festuca glauca* 'Elijah Blue'

## FLOWERING PERENNIALS



WHITE YARROW  
*Achillea millefolium*



FOOTHILL PENSTEMON  
*Penstemon heterophyllus*  
'Blue Springs'



SANTA BARBARA DAISY  
*Erigeron karvinskianus*



SEA PINK  
*Armeria maritima*



HUMMINGBIRD SAGE  
*Salvia spathacea*

## HERBACEOUS GROUNDCOVERS



BUGLEHERB  
*Ajuga reptans*

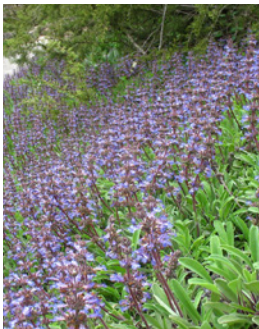

CREeping SAGE  
*Salvia sonomensis*



WILD STRAWBERRY  
*Fragaria vesca*

# UNDERSTORY SPECIES PHOTOS: PASEO

## SHRUBS



**PINK -FLOWERED CURRANT**  
*Ribes sanguineum glutinosum*



**EVERGREEN CURRANT**  
*Ribes Viburnifolium*



**DWARF OLIVE**  
*Olea europea 'Little Ollie'*



**LONG LEAFED YELLOWWOOD**  
*Podocarpus henkelii*



**BUSH ANEMONE**  
*Carpenteria californica*

## GRASSES, FERNS & VINES



**MEADOW SEDGE**  
*Carex praegracilis*



**DWARF SEDGE**  
*Carex tumulicola (C. divulsa)*



**WHITE YARROW**  
*Achillea millefolium*



**POLYPODY FERN**  
*Polypodium californicum*



**JASMINE**  
*Jasmine officiale f. grandiflorum*

## FLOWERING PERENNIALS



**Hummingbird Sage**  
*Salvia spathacea*



**CREeping OREGON GRAPE**  
*Berberis aquifolium var. repens*



**JAPANESE ANEMONE**  
*Anemone japonica*



**Canyon Snow Pacific Iris**  
*Iris douglasiana x 'Canyon Snow'*



**ROCKROSE**  
*Cistus ladanifer*

## FLOWERING PERENNIALS

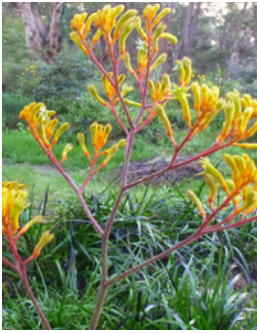

**ISLAND ALUMROOT**  
*Heuchera maxima*

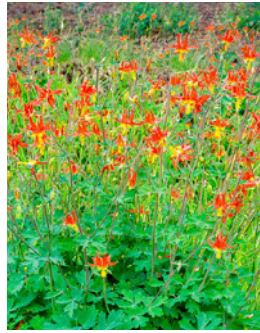

**COLUMBINE**  
*Aquilegia formosa*



**SEA PINK**  
*Armeria maritima*



**ROCK PURSLANE**  
*Calandrinia Spp.*



**CRANESBILL**  
*Geranium sanguineum*

# UNDERSTORY SPECIES PHOTOS: PLAZA

## SHRUBS



VALLEY VIOLET  
MARITIME CEANOTHUS  
*Ceanothus maritimus*  
'Valley Violet'



DWARF OLIVE  
*Olea europea* 'Little  
Ollie'



LONG LEAFED YELLOWWOOD  
*Podocarpus*  
*henkelii*

## GRASSES



MEADOW SEDGE  
*Carex praegracilis*



MOOR GRASS  
*Sesleria autumnalis*



AEONIUM  
*Aeonium* spp.



HENS AND CHICKS  
*Echeveria* spp.

## FLOWERING PERENNIALS



ALBUCA HUMILIS  
*Albuca humilis*

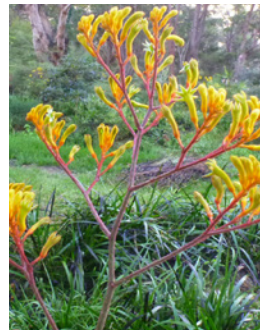

KANGAROO PAW  
*Anigozanthus* spp.

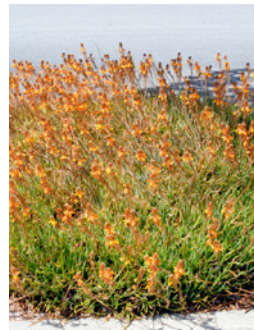

BULBINE  
*Bulbine frutescens*

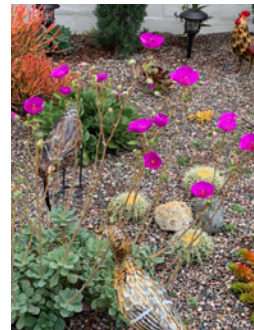

ROCK PURSLANE  
*Calandrinia* Spp.

## FLOWERING PERENNIALS



FOOTHILL PENSTEMON  
*Penstemon hetero-*  
*phyllus* 'Blue Springs'



COAST ROSEMARY  
*Westringia fruticosa*



WOOLLY BLUE CURLS  
*Trichostema lanatum*



DE LA MINA LILAC  
*Verbena lilacina* 'De La Mina'

# UNDERSTORY SPECIES PHOTOS: PASSIVE GREEN SPACE

## SHRUBS



RAY HARTMAN CALIFORNIA LILAC  
*Ceanothus 'Ray Hartman'*



CALIFORNIA LILAC  
*Ceanothus thrysiflorus*



TOYON  
*Heteromeles arbutifolia*



WESTERN SPICE BUSH  
*Calycanthus occidentalis*

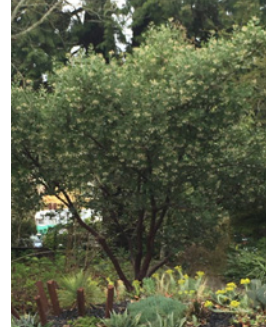

ST HELENA MANZANITA  
*Arctostaphylos manzanita 'St Helena'*

## GRASSES



DWARF SEDGE  
*Carex tumulicola (C. divulsa)*



DUNE SEDGE  
*Carex pansa*



FEATHER REED GRASS  
*Calamagrostis x acutifolia 'Karl Foerster'*



PINE MUHLY GRASS  
*Muhlenbergia dubia*



DEERGRASS  
*Muhlenbergia rigens*

## FLOWERING PERENNIALS



CREeping OREGON GRAPE  
*Berberis aquifolium var. repens*



CALIFORNIA BARBERRY  
*Berberis pinnata ssp. Insularis*



FINGE CUPS  
*Tellima grandiflora*

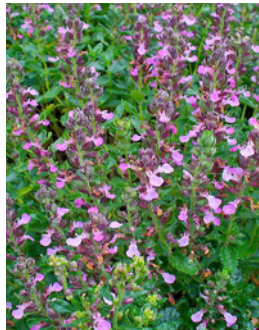

WALL GERMANDER  
*Tiarella cordifolia*

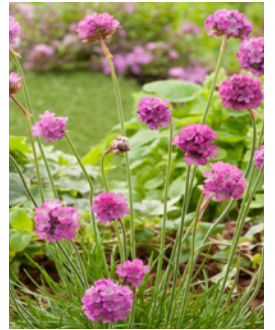

SEA PINK  
*Armeria maritima*

## FLOWERING PERENNIALS



COREOPSIS  
*Coreopsis grandiflora*



CALIFORNIA BUSH SUNFLOWER  
*Encelia Californica*



APACHE PLUME  
*Fallugia paradoxa*

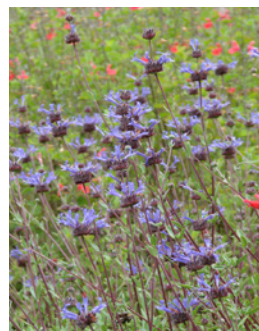

WINNIFRED GILMAN CLEVELAND SAGE  
*Salvia clevelandii 'Winnifred Gilman'*



HUMMINGBIRD SAGE  
*Salvia spathacea*



# UNDERSTORY SPECIES PHOTOS: PARKING LOTS

## TALL SHRUBS



VALLEY VIOLET MARITIME  
CEANOTHUS  
*Ceanothus maritimus*  
'Valley Violet'



EVE CASE COFFEEBERRY  
*Rhamnus californica*  
'Eve Case'



DWARF OLIVE  
*Olea europea* 'Little  
Ollie'



VINE HILL MANZANITA  
*Arctostaphylos*  
*densiflora* 'Howard  
McMinn'

## GROUNDCOVER SHRUBS



EMERALD CARPET  
MANZANITA  
*Arctostaphylos*  
'Emerald Carpet'



PACIFIC MIST MANZANITA  
*Arctostaphylos* 'Pacific Mist'



WARRIOR LYTLE  
CALIFORNIA BACKWHEAT  
*Eriogonum fasciculatum*  
'Warriner Lytle'



POINT REYES CEANOTHUS  
*Ceanothus gloriosus*

## GRASSES



PINE MUHLY  
*Muhlenbergia dubia*



DEERGRASS  
*Muhlenbergia rigens*



MOOR GRASS  
*Sesleria autumnalis*



TUFTED HAIR GRASS  
*Deschampsia cespitosa*



DUNE SEDGE  
*Carex pansa*

## FLOWERING PERENNIALS

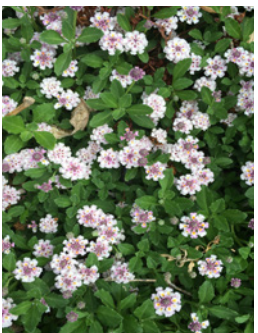

LIPPIA  
*Phylla nodiflora*



SANTA BARBARA DAISY  
*Erigeron karvinski-*  
*anus*

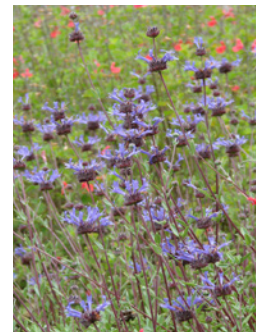

WINNIFRED GILMAN  
CLEVELAND SAGE  
*Salvia clevelandii*  
'Winnifred Gilman'



WOOLLY BLUE CURLS  
*Trichostema lanatum*

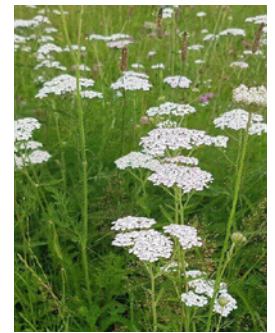

WHITE YARROW  
*Achillea millefolium*

# UNDERSTORY SPECIES PHOTOS: BIORETENTION AND BIOSWALES

## SHRUBS



DWARF COYOTE BUSH  
*Baccharis pilularis*  
'Twin Peaks'



WESTERN SPICE BUSH  
*Calycanthus occidentalis*

## GRASSES



BERKELEY SEDGE  
*Carex tumulicola*



DEER GRASS  
*Muhlenbergia rigens*



REED GRASS  
*Calamagrostis nutkaensis*



DUNE SEDGE  
*Carex pansa*



GREEN RUSH  
*Juncus effusus*

## FLOWERING PERENNIALS



WESTERN GOLDENTOP  
*Euthamia occidentalis*



WHITE YARROW  
*Achillea millefolium*



GUM WEED  
*Grindelia camporum*



CALIFORNIA MILKWEED  
*Calochortus luteus*

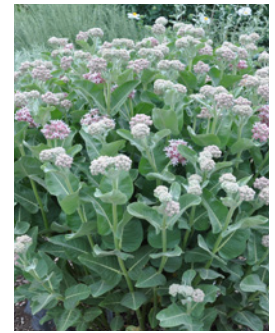

SHOWY MILKWEED  
*Asclepias speciosa*

## FLOWERING PERENNIALS



TALL FLATSEDGE  
*Cyperus ergagrostis*



DOUGLAS IRIS  
*Iris douglasiana*

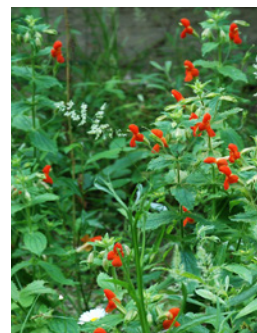

SCARLET MONKEYFLOWER  
*Mimulus cardinalis*



BLUEDICKS  
*Dichelostemma capi-  
tatum*



WAYNE RODERICK DAISY  
*Erigeron glaucus* 'Wayne  
Roderick'

# UNDERSTORY SPECIES PHOTOS: RIPARIAN

## SHRUBS



TOYON  
*Heteromeles arbutifolia*



CALIFORNIA WILD ROSE  
*Rosa californica*



CALIFORNIA COFFEEBERRY  
*Rhamnus californica*

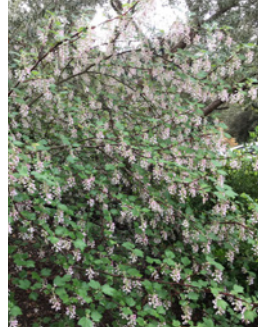

PINK-FLOWERED CURRANT  
*Ribes sanguineum glutinosum*

## GRASSES



TUFTED HAIR GRASS  
*Deschampsia cespitosa*



DUNE SEDGE  
*Carex pansa*



DWARF SEDGE  
*Carex tumulicola (C. divulsa)*



DEERGRASS  
*Muhlenbergia rigens*

## FLOWERING PERENNIALS



COYOTE MINT  
*Monardella villosa*



WHITE YARROW  
*Achillea millefolium*



DEER WEED  
*Acmispon glaber*



CALIFORNIA GOLDENROD  
*Solidago californica*

## FLOWERING PERENNIALS



CALIFORNIA BUSH  
SUNFLOWER  
*Encelia Californica*



NAKED BUCKWHEAT  
*Eriogonum nudum*



SULFUR BUCKWHEAT  
*Eriogonum umbellatum*



WESTERN GOLDENTOP  
*Euthamia occidentalis*

# UNDERSTORY SPECIES PHOTOS: LANDSCAPE BUFFER / SLOPES

## SHRUBS



**HOOKER MANZANITA**  
*Arctostaphylos hookeri*

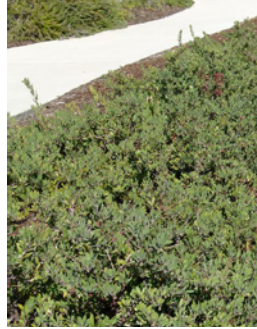

**PACIFIC MIST MANZANITA**  
*Arctostaphylos 'Pacific Mist'*



**BAKERS MANZANITA**  
*Arctostaphylos bakeri 'Louis Edmunds'*



**RAY HARTMAN CALIFORNIA LILAC**  
*Ceanothus 'Ray Hartman'*



**CALIFORNIA LILAC**  
*Ceanothus thyrsiflorus*

## GRASSES



**PURPLE NEEDLE GRASS**  
*Stipa pulchra*



**ALKALI SACATON**  
*Sporobolus airoides*



**CANYON PRINCE WILDRYE**  
*Leymus condensatus 'Canyon Prince'*



**PINE MUHLY GRASS**  
*Muhlenbergia dubia*



**CREEPING WILDRYE**  
*Elymus triticoides*

## FLOWERING PERENNIALS



**CALIFORNIA BARBERRY**  
*Berberis pinnata ssp. Insularis*



**WESTERN GOLDENTOP**  
*Euthamia occidentalis*



**CREEPING OREGON GRAPE**  
*Mahonia repens*



**STICKY MONKEY FLOWER**  
*Mimulus auranticus*



**INDIAN MALLOW**  
*Abutilon palmeri*

## FLOWERING PERENNIALS



**TRAILING ROSEMARY**  
*Rosmarinus officinalis*



**FOOTHILL PENSTEMON**  
*Penstemon heterophyllus 'Blue Springs'*



**CREEPING SAGE**  
*Salvia leucophylla 'Bee's Bliss'*



**HUMMINGBIRD SAGE**  
*Salvia spathacea*



**Valley Violet** *Ceanothus Ceanothus maritimus 'Valley Violet'*



## REFERENCES

- Canopy. (2020) Canopy Tree library. <https://canopy.org/tree-info/canopy-tree-library/>
- CASQA. Planting Inundation Zones. (July 31, 2017).
- City of San Jose. (2020). San Jose Community Forest Management Plan. <https://sanjosecfmp.com/Designs>, Susan Brown. Salinity Management, [www.salinitymanagement.org/](http://www.salinitymanagement.org/).
- WateReuse Foundation. (October 1, 2007). Salinity Management Guide. <http://salinitymanagement.com/Salinity%20Management%20Guide/index.html>
- Hagerty, S.; Spotswood, E.; McKnight, K.; Grossinger, R. M. (2019). Urban Ecological Planning Guide for Santa Clara Valley. SFEI Contribution No. 941. San Francisco Estuary Institute: Richmond, CA.
- H. T. Harvey & Associates. (February, 2018). Integrating Nature into the Urban Landscape A Design Guide. <https://www.harveyecology.com/sites/default/files/UrbanDesignGuide.pdf>
- H. T. Harvey & Associates (24 July 2015) Plant Palette Recommendations for the North Bayshore Precise Plan Project # 3640-01. Prepared for: The City of Mountain View.
- Our City Forest. (2020) Our City Forest Planting the Future. [www.ourcityforest.org/](http://www.ourcityforest.org/).
- Santa Clara Valley Transportation Authority, Sustainable Landscape Policy. Document Number 340.003, Version 2, Date 09/26/2018
- Santa Clara Valley Transportation Authority, Green Building Policy. Document Number 400.004, Version 1, Date 08/07/2018
- Santa Clara Valley Water District. (2020). Landscape Rebate Program Qualifying Plant List. [https://scvwd.dropletportal.com/public/pdf/plant\\_list/full/](https://scvwd.dropletportal.com/public/pdf/plant_list/full/).
- Santa Clara Valley Urban Run-off Pollution Prevention Program (2016) Stormwater Design Criteria Manual 016\_Appendix\_D - Plant List and Recommendations for Stormwater Management Areas.
- San Francisco Estuary Institute-Aquatic Science Center, 2017. Re-Oaking Silicon Valley: Building Vibrant Cities with Nature. Publication # 825, San Francisco Estuary Institute, Richmond, CA. Version 1.1, August 2017. Report is available at <http://resilientsv.sfei.org/>
- Trees of Stanford and Environs Ronald N. Bracewell ; with a foreword by Donald Kennedy. Imprint Stanford, Calif. : Stanford Historical Society, c2005. <http://trees.stanford.edu/>
- University of California, Division of Agriculture and Natural Resources. "UC Master Gardeners of Santa Clara County, CA." UC Master Gardeners of Santa Clara County, [mgsantaclara.ucanr.edu/](http://mgsantaclara.ucanr.edu/).
- Urban Forest Ecosystems Institute: Cal Poly San Luis Obispo "A Tree Selection Guide." [SelectTree, selectree.calpoly.edu/](http://selectree.calpoly.edu/).
- Wu, Lin, and Linda Dodge. "Landscape Plant Salt Tolerance Selection Guide for Recycled Water Irrigation." A Special Report for the Elvenia J. Slosson Endowment Fund, 2005.



**ATTACHMENT B:**

B2: COMPARISON OF VTA TREE  
PLANTING GUIDELINES TO SCVURPPP  
TREE GUIDELINES



| TREES: Comparison of RELM Guidelines and SCVURPPP Bioretention Trees              |                                       |   |   |                     |                           |                                  |                 |            |                   |                   |        |        |                     |             |          |                |              |
|---|---------------------------------------|---|---|---------------------|---------------------------|----------------------------------|-----------------|------------|-------------------|-------------------|--------|--------|---------------------|-------------|----------|----------------|--------------|
| LEGEND:   |                                       |   |   |                     |                           |                                  |                 |            |                   |                   |        |        |                     |             |          |                |              |
| Orange = Trees in both SCVURPPP & VTA bioretention lists                          |                                       |   |   |                     |                           |                                  |                 |            |                   |                   |        |        |                     |             |          |                |              |
| Blue = Trees in both lists, SCVURPPP as bioretention, VTA <b>not</b> bioretention |                                       |   |   |                     |                           |                                  |                 |            |                   |                   |        |        |                     |             |          |                |              |
| Not highlighted = Trees not in SCVURPPP bioretention list                         |                                       |   |   |                     |                           |                                  |                 |            |                   |                   |        |        |                     |             |          |                |              |
| Latin Name  | Common Name                           | Comments/ Notes   | Decid / Evgrn / Flwr / Confr / Shrub-like | Mature Size H' X W' | WATER USE WUCOL San Jose* | Salt Tolerance for RCW (H,M,L)** | CA Native (Y/N) | TYPOLOGIES | MAJOR STREETSCAPE | MINOR STREETSCAPE | PASEOS | PLAZAS | PASSIVE GREEN SPACE | PARKING LOT | RIPARIAN | SLOPE - BUFFER | BIORETENTION |
| <i>Acer macrophyllum</i>  | Big Leaf Maple                        | Shade, consistent moisture, protected   | Decid                                     | 30-75' x 30-50'     | M                         | M                                | Y               |            |                   |                   |        |        | X                   |             | X        |                | X            |
| <i>Celtis laevigata var. reticulata</i>   | Netleaf Hackberry (Western Hackberry) | Dry fruit litter  | Decid                                     | 25'-30' x 25'-30'   | L                         | L/M                              | Y               |            |                   |                   |        |        |                     |             |          |                | X            |
| <i>Laurus nobilis</i>   | Grecian Laurel                        | Sensitive to clay soils and poor drainage, plant only in bioswales                | Evgrn                                     | 15-20' x 20-25'     | L                         | M                                | N               |            |                   |                   |        |        |                     |             |          |                | X            |
| <i>Arbutus x 'Marina'</i>   | Marnia Madrone                        | Standard for Streets/Pkg Lots, Mutli for Planting                                 | Evgrn / Flwer                             | 40-50' x 25-40'     | L                         | M                                | N               |            |                   |                   | X      |        | X                   |             |          |                |              |
| <i>Carpinus betulus</i>   | Fastigate European Hornbeam           | Hedge, Perimeter  | Decid / Flwer                             | 35-40' x 20-30'     | M                         | M                                | N               |            |                   |                   |        |        |                     |             |          |                | X            |
| <i>Cercis canadensis var. texensis</i>  | Oklahoma Redbud                       | Smaller, Bushier Tree   | Decid / Flwer                             | 25-35' x 25-35'     | L/M                       | L                                | N               |            |                   |                   |        |        |                     |             |          |                | X            |
| <i>Cercis occidentalis</i>  | Western Redbud                        | Local native, flowering, needs good drainage                                      | Decid / Flwer                             | 12-20' x 20-15'     | L                         | M                                | Y               |            |                   |                   | X      |        | X                   |             | X        | X              |              |
| <i>Geijera parviflora</i>   | Australian Willow                     | More commonly planted in southern CA, select good structure in nursery            | Evergreen                                 | 25-35' x 20'        | L                         | H                                | N               |            | X                 | X                 |        |        |                     | X           |          |                |              |
| <i>Ginkgo biloba "Autumn Gold"</i>  | Maidenhair Tree                       | Can turn back to female, Use sparingly in narrow conditions for yellow fall color | Decid                                     | 25-50' x 25-35'     | M                         | L                                | N               |            |                   | X                 | X      |        |                     |             |          |                |              |
| <i>Koelreuteria bipinnata</i>   | Chinese Flame Tree                    | Good shade trees  | Decid / Flwer                             | 20-35' x 25-40'     | M                         | M                                | N               |            | X                 | X                 |        | X      |                     | X           |          |                |              |
| <i>Lagerstroemia spp. (Not Recommended) ***</i>                                   | Crepe Myrtle ***                      | Only to match existing street trees, over planted in San Jose                     | Decid / Flwer                             | 25' x 25'           | L                         | L                                | N               |            |                   |                   |        |        |                     |             |          |                |              |
| <i>Platanus x acerifolia (Not Recommended) ***</i>                                | London Plane Tree ***                 | Only to match existing street trees, overplanted in San Jose                      | Decid                                     | 70-85' x 50-70'     | L                         | M                                | N               |            |                   |                   |        |        |                     |             |          |                |              |
| <i>Prunus ilicifolia ssp. lyonii</i>  | Catalina Cherry                       | Wildlife value, fruiting, good screen   | Decid / Flwer                             | 25-35' x 20-30'     | L                         | M                                | Y               |            |                   |                   |        |        |                     |             | X        | X              |              |
| <i>Quercus agrifolia</i>  | Coast Live Oak                        | Needs large planting area, drops acorns   | Evgrn                                     | 20-70' x 20-70'     | L                         | M                                | Y               |            |                   |                   |        |        | X                   | X           | X        | X              |              |
| <i>Quercus ilex (Not recommended) ***</i>   | Holly Oak ***                         | Only to match existing street trees   | Evgrn                                     | 30-60' x 30-60'     | L                         | M                                | N               |            |                   |                   |        |        |                     |             |          |                |              |
| <i>Quercus suber</i>  | Cork Oak                              | Needs large planting area   | Evgrn                                     | 50'-70' x 50' - 70' | L                         | M                                | N               |            | X                 | X                 |        | X      |                     | X           |          |                |              |
| <i>Quercus wislizenii</i>   | Interior Live Oak                     | Difficult to source   | Evgrn                                     | 30-70' x 40-80'     | L                         | L                                | Y               |            |                   |                   |        |        |                     |             |          | X              |              |
| <i>Acer buergerianum</i>  | Trident Maple                         | Non, native but may be better at handling summer drought of bioswales             | Decid                                     | 25'-30' x 25'-30'   | M                         | M                                | N               |            |                   | X                 | X      |        |                     |             |          |                | X            |
| <i>Acer negundo californicum</i>  | California Box Elder                  | Fall color, may be slightly more drought tolerant than Acre macrophyllum          | Decid                                     | 20'-30' x 20'-30'   | M                         | L                                | Y               |            |                   |                   |        |        |                     |             | X        |                | X            |
| <i>Alnus rhombifolia</i>  | White Alder                           | Water - But Riparian, Bioswale  | Decid / Flwer                             | 50-90' x 40-70'     | M                         | M                                | Y               |            |                   |                   |        |        |                     |             |          |                | X            |
| <i>Celtis sinensis</i>  | Chinese Hackberry                     | Dry fruit litter suseptible to Asian woolly aphid                                 | Decid                                     | 25-35' x 25-30'     | L                         | L                                | V               |            |                   |                   |        |        |                     |             |          |                | X            |
| <i>Fraxinus latifolia</i>   | Oregon Ash                            | wooded, Emerald Ash Borer but could be applicable in select parking lot bioswales | Decid                                     | 65-80' x 50'        | M                         | M                                | Y               |            |                   |                   |        |        |                     | X           |          |                | X            |
| <i>Fraxinus velutina</i>  | Arizona Ash                           | Weak wooded, Emerald Ash Borer, older trees require significant maintenance       | Decid                                     | 30-50' x 30-40'     | M                         | M                                | Y               |            |                   |                   |        |        |                     | X           |          |                | X            |
| <i>Hesperocyparis forbesii</i>  | Tecate Cypress                        |   | Conifer                                   | 10-25' x 20'        | L                         | H                                | Y               |            |                   |                   |        |        | X                   |             |          | X              | X            |

| Latin Name  | Common Name                | Comments/ Notes  | Decid / Evgrn / Flwr / Confr / Shrub-like | Mature Size H' X W'   | WATER USE WUCOL San Jose* | Salt Tolerance for RCW (H,M,L)** | CA Native (Y/N) | TYPOLOGIES | MAJOR STREETSCAPE | MINOR STREETSCAPE | PASEOS | PLAZAS | PASSIVE GREEN SPACE | PARKING LOT | RIPARIAN | SLOPE - BUFFER | BIORETENTION |
|---|----------------------------|--|---|-----------------------|---------------------------|----------------------------------|-----------------|------------|-------------------|-------------------|--------|--------|---------------------|-------------|----------|----------------|--------------|
| <i>Juglans californica</i>                              | California Black Walnut    | Drops large fruit, Not over pedestrian areas                                     | Decid                                     | 15' - 30' x 15' - 30' | L                         | L                                | Y               |            |                   |                   |        |        |                     |             | X        | X              | X            |
| <i>Plantanus racemosa</i>                               | Western Sycamore           | Use in bioswales, Ensure that nursery stock is straight species, not hybridized. | Decid                                     | 30-80' x 20-50'       | M                         | M                                | Y               |            |                   |                   |        |        |                     |             |          |                | X            |
| <i>Populus fremontii</i>                                | Fremont Cottonwood         | gold fall color, surface roots, weak branches                                    | Decid                                     | 40-80' x 30-50'       | M                         | M                                | Y               |            |                   |                   |        |        |                     |             | X        |                | X            |
| <i>Quercus lobata</i>                                   | Valley Oak                 |  | Decid                                     | 50-70' x 50'          | L                         | L/M                              | Y               |            | X                 |                   |        | X      |                     | X           | X        |                | X            |
| <i>Quercus virginiana</i>                               | Southern Live Oak          | Needs large planting area  | Evgrn                                     | 40-80' x 60-100'      | M                         | M                                | N               |            |                   |                   |        | X      | X                   | X           |          |                | X            |
| <i>Sambucus nigra ssp. caerulea</i>                     | Blue Elderberry            | Habitat value, riparian, can limit visibility                                    | Decid / Flwer                             | 20 x 20'              | L                         | M                                | Y               |            |                   |                   |        |        |                     |             | X        | X              | X            |
| <i>Taxodium distichum</i>                               | Bald Cypress               | Use at bottom of bioswales that allow tree                                       | Conifer / Decid                           | 60-80 x 20-30;        | M                         | L                                | N               |            |                   |                   |        |        |                     |             |          |                | X            |
| <i>Aesculus californica</i>                             | California Buckeye         | Wildlife value, Summer Deciduous   | Decid / Flwer                             | 20-30' x 15-30'       | L                         | L /M                             | Y               |            |                   |                   |        |        | X                   |             | X        | X              |              |
| <i>Afrocarpus gracilior</i>                             | African Fern Pine          | Find Good Proven Example   | Evgrn / Conifer                           | 50-65' x 20-30'       | L                         | M                                | N               |            | X                 |                   |        |        |                     | X           |          |                |              |
| <i>Agonis flexuosa</i>                                  | Peppermint Tree            |  | Evgrn                                     | 25-35' x 15'-30'      | M                         | M                                | N               |            |                   | X                 |        |        |                     | X           |          | X              |              |
| <i>Arbutus unedo</i>                                    | Strawberry Madrone         | Single Stem, Fruiting, Not over Pvmt   | Evgrn / Flwer                             | 20-30' x 15-40'       | L                         | M                                | N               |            |                   |                   |        |        |                     |             |          | X              |              |
| <i>Brachychiton populneus</i>                           | Kurrajong                  | Pale Cream Flowers   | Decid / Flwer                             | 50-60' x 30-40'       | L                         | M                                | N               |            |                   |                   |        |        | X                   |             |          |                |              |
| <i>Calocedrus decurrens</i>                             | Incense Cedar              | Large planting area required   | Conifer                                   | 50'-80" x 30-40'      | L                         | L                                | Y               |            |                   |                   |        |        | X                   |             |          | X              |              |
| <i>Cedrus atlantica glauca 'fastigata'</i>              | Columnar Blue Atlas Cedar  | Good Narrow Tree - Screen, Hedge   | Conifer                                   | 40-60' x 25-40'       | L                         | M                                | N               |            |                   |                   | X      |        |                     |             |          | X              |              |
| <i>Cedrus deodara</i>                                   | Deodar Cedar               | Large planting area required   | Conifer                                   | 40-60' x 20-30'       | L                         | M                                | N               |            |                   |                   |        |        | X                   |             |          | X              |              |
| <i>Chilopsis linearis 'Bubba'</i>                       | Desert Willow              | Small flowering accent tree, native to southern Cali                             | Decid / Flwer                             | 12-20' x 10-15'       | L                         | H                                | Y               |            |                   |                   | X      |        | X                   | X           |          | X              |              |
| <i>Chionanthus retusus</i>                              | Chinese Fringetree         | Small flowering accent tree  | Decid / Flwer                             | 10-20' X 6-12'        | M                         | M                                | N               |            |                   |                   | X      |        |                     |             |          |                |              |
| <i>Chitalpa tashkentensis 'Pink Dawn'</i>               | Pink Dawn Chitalpa         | Cross between Catalpa nad Chilopsis, Smaller flowering tree                      | Decid / Flwer                             | 25-35' x 25-35'       | L                         | M                                | N               |            |                   | X                 | X      | X      |                     | X           |          |                |              |
| <i>Corylus cornuta var. californica</i>                 | Western Hazelnut           | Shade only, protected areas  | Decid / Flwer                             | 15-18' x 12-18"       | M                         | M                                | Y               |            |                   |                   | X      |        |                     |             | X        | X              |              |
| <i>Corymbia ficifolia</i>                               | Red Flowering Gum          | Good Wildlife Plant, Salt Tolerant   | Evgrn / Flwer                             | 18-45' x 15-60'       | L                         | H                                | N               |            | X                 |                   |        |        |                     |             |          |                |              |
| <i>Gledistia triacanthos var. inermis 'Shademaster'</i> | Thornless Honey Locust     | Fast growing, minimal seed pods, ensure good structure at nursery                | Decid / Flwer                             | 45' x 35'             | L                         | L                                | N               |            |                   | X                 | X      | X      |                     |             |          |                |              |
| <i>Hesperocyparis arizonica</i>                         | Arizona Cyress             | Screen tree, can be used at edges of bioswales                                   | Conifer                                   | 30-40' x 15-20'       | L                         | H                                | N               |            |                   |                   |        |        | X                   |             |          | X              |              |
| <i>Lophostemum confertus</i>                            | Brisbane Box               |  | Evgrn / Flwer                             | 30-50 x 10-30'        | L                         | M                                | N               |            | X                 | X                 |        |        |                     | X           |          |                |              |
| <i>Lyonothamnus floribundus</i>                         | Catalina Ironwood          | Needs drainage, good in tight groves   | Evgrn / Flwer                             | 25-50' x 12-24'       | L                         | M                                | Y               |            |                   |                   | X      |        | X                   |             |          | X              |              |
| <i>Maleleuca ericifolia</i>                             | Swamp Paperbark            | Salt tolerant  | Evgrn / Flwer                             | 20-40' X 15-25'       | L                         | H                                | N               |            |                   |                   |        |        | X                   |             |          |                |              |
| <i>Melaleuca stypheliodes</i>                           | Prickly Paperbark          | Salt tolerant, often multi-trunked   | Evgrn / Flwer                             | 30-40' x 10-20'       | L                         | M                                | N               |            |                   |                   | X      |        | X                   | X           |          |                |              |
| <i>Metrosideros excelsa</i>                             | New Zealand Christmas Tree |  | Evgrn / Flwer                             | 30-35' x 30-35'       | L                         | M                                | N               |            |                   | X                 | X      |        |                     | X           |          |                |              |





| Latin Name  | Common Name                 | Comments/ Notes  | Decid / Evgrn /<br>Flwr / Confr /<br>Shrub-like | Mature Size<br>H' X W' | WATER<br>USE<br>WUCOL<br>San<br>Jose* | Salt<br>Tolerance<br>for RCW<br>(H,M,L)** | CA<br>Native<br>(Y/N) | TYPLOGIES | MAJOR<br>STREETSCAPE | MINOR<br>STREETSCAPE | PASEOS | PLAZAS | PASSIVE<br>GREEN SPACE | PARKING<br>LOT | RIPARIAN | SLOPE -<br>BUFFER | BIORETENTION |
|---|-----------------------------|--|---|------------------------|---------------------------------------|---|-----------------------|-----------|----------------------|----------------------|--------|--------|------------------------|----------------|----------|-------------------|--------------|
| <i>Olea europea</i> 'Swan Hill'                   | Fruitless Olives            | also Wilsonii, multitrunk - can be limbed up to height of 8' clear if needed | Evgrn   | 25-30' x 25-30'        | L                                     | M   | N                     |           |                      |                      | X      | X      | X                      | X              |          |                   |              |
| <i>Parkinsonia x</i> 'Desert Museum'              | Palo Verde                  | Native to desert southwest   | Decid / Flwr                                    | 15-25' x 15-20'        | L                                     | H   | Y                     |           |                      |                      | X      | X      | X                      |                |          |                   |              |
| <i>Pinus eldarica</i>                             | Mondell Pine                | Tolerates Clay Soi   | Conifer   | 30-80' x 15-25'        | L                                     | M   | N                     |           | X                    |                      |        |        |                        | X              |          | X                 |              |
| <i>Pinus torreyana</i>                            | Torrey Pine                 | Very large cones, not over pedestrian/parking areas                          | Conifer   | 40-60' x 20-30'        | L                                     | M   | Y                     |           |                      |                      |        |        |                        |                | X        | X                 |              |
| <i>Pistacia chinensis</i> (Not Recommended) ***   | Chinese Pistache ***        | Only to match existing street trees, overplanted in San Jose                 | Decid / Flwr                                    | 25-35' x 25-35'        | L                                     | M   | N                     |           |                      |                      |        |        |                        |                |          |                   |              |
| <i>Propospis glandulosa</i> 'Maverick'            | Thornless Honey Mesquite    | Spreading, need sufficient planter width, Native to desert southwest         | Decid / Flwr                                    | 25-35' x 20-35'        | N/A                                   | H   | Y                     |           |                      |                      |        |        | X                      | X              |          |                   |              |
| <i>Prunus serrulata</i> 'Kwanzan'                 | Japanese Flowering Cherry   | Needs good drainage, no clay soils   | Decid / Flwr                                    | 30' x 20-30'           | M                                     | M   | N                     |           |                      |                      |        | X      |                        |                |          |                   |              |
| <i>Pyrus calleryana</i> (Not Recommended) ***     | Callary Pear ***            | Only to match existing street trees, Invasive in waterways                   | Decid / Flwr                                    | 15-30' x 10-25'        | M                                     | M   | N                     |           |                      |                      |        |        |                        |                |          |                   |              |
| <i>Quercus douglasii</i>                          | Blue Oak                    | Habitat species, difficult to source/establish                               | Decid   | 20-70' x 20-70'        | L                                     | L   | Y                     |           |                      |                      |        |        |                        |                |          |                   |              |
| <i>Quercus engelmannii</i>                        | Engelmann Oak               | Needs large planting area  | Evgrn   | 50-65' x 80-120'       | L                                     | M   | Y                     |           | X                    |                      |        | X      |                        | X              |          |                   |              |
| <i>Quercus frainetto</i> 'Schmidt'                | Hungarian Oak               | Grafted, good symmetry potential   | Decid   | 100' x 70'             | L                                     | L   | N                     |           |                      |                      |        | X      |                        | X              |          |                   |              |
| <i>Quercus fusiformis</i>                         | Escarpment (Texas) Live Oak | Similar to Q. Virginiana, more drought tol.                                  | Semi-Deciduous                                  | 20-40' x 20-40'        | L                                     | M   | N                     |           |                      | X                    |        | X      | X                      | X              |          |                   |              |
| <i>Quercus hypoleucoides</i>                      | Silverleaf Oak              | Difficult to source, but great tree  | Evgrn   | 30-60' x 20-30'        | L                                     | M   | Y                     |           |                      |                      | X      |        | X                      |                |          | X                 |              |
| <i>Quercus kelloggii</i>                          | California Black Oak        | Local Native, slow growing, difficult to source                              | Decid   | 30-70' x 30-50'        | L                                     | M   | Y                     |           |                      |                      |        |        | X                      |                |          | X                 |              |
| <i>Quercus rugosa</i>                             | Netleaf Oak                 |  | Evgrn   | 30-50' x 20-30'        | L                                     | M   | N                     |           | X                    | X                    |        |        |                        | X              |          | X                 |              |
| <i>Quercus tomentella</i>                         | Island Oak                  |  | Evgrn   | 20-50' x 25-40'        | L                                     | L   | Y                     |           |                      | X                    | X      |        | X                      |                |          | X                 |              |
| <i>Salix laevigata</i>                            | Red Willow                  | Habitat value, riparian, can limit visibility                                | Evgrn-Shrub-like                                | 25-50' x 15-35'        | M                                     | M   | Y                     |           |                      |                      |        |        |                        |                | X        |                   |              |
| <i>Salix lasiolepis</i>                           | Arroyo Willow               | Habitat value, riparian, can limit visibility                                | Evgrn-Shrub-like                                | 10-35'                 | M                                     | M   | Y                     |           |                      |                      |        |        |                        |                | X        |                   |              |
| <i>Sequoia Sempervirens</i> (Not recommended) *** | Coastal Redwood ***         | High Water Use, use only to match  | Conifer   | 70-100' x 15-30        | H                                     | L   | Y                     |           |                      |                      |        |        |                        |                |          |                   |              |
| <i>Tilia tomentosa</i> 'Sterling'                 | Sterling Linden             |  | Decid   | 40-50' x 20-30'        | L                                     | M   | N                     |           | X                    | X                    | X      |        |                        |                |          |                   |              |
| <i>Tristaniopsis laurina</i> 'Elegant'            | Elegant Water Gum           |  | Evgrn   | 20-35' x 15-25'        | M                                     | M   | N                     |           | X                    | X                    | X      |        |                        | X              |          |                   |              |
| <i>Ulmus parvifolia</i>                           | Chinese Elm                 | Emer II', Fronteir, Spermvirens, good fast growing shade tree                | Semi-Deciduous                                  | 35-45' x 35-50'        | M                                     | M   | N                     |           |                      |                      |        |        | X                      |                |          |                   |              |



**ATTACHMENT B:**

**B3: COMPARISON OF VTA UNDERSTORY  
PLANTING GUIDELINES TO SCVURPPP  
UNDERSTORY GUIDELINES**



| UNDERSTORY: Comparison of RELM Guidelines and SCVURPPP Bioretention Understory  |                      |                        |   |                        |                   |                  |  |   |                         |  |           |                      |                      |        |        |                        |                |          |                   |              |
|---|----------------------|------------------------|---|------------------------|-------------------|------------------|--|---|-------------------------|--|-----------|----------------------|----------------------|--------|--------|------------------------|----------------|----------|-------------------|--------------|
| <b>LEGEND:</b><br>Orange = Understory in both SCVURPPP & VTA bioretention lists<br>Blue = Understory in both lists, SCVURPPP as bioretention, VTA <b>not</b> bioretention<br>Not highlighted = Understory not in SCVURPPP bioretention list |                      |                        |   |                        |                   |                  |  |   |                         |  |           |                      |                      |        |        |                        |                |          |                   |              |
| Latin Name  | Common Name          | Plant Type             | Notes   | Mature Size<br>H' X W' | Sun / Shade       | Evrgm /<br>Decid | WATER<br>USE<br>WUCOLS<br>(San<br>Jose)* | Salt<br>Tolerance for<br>RCW<br>(H,M,L)** | Cali<br>Native<br>(Y/N) | Region of<br>Origin (if not<br>native to Cali) | TYPLOGIES | MAJOR<br>STREETSCAPE | MINOR<br>STREETSCAPE | PASEOS | PLAZAS | PASSIVE<br>GREEN SPACE | PARKING<br>LOT | RIPARIAN | SLOPE -<br>BUFFER | BIORETENTION |
| <i>Achillea millefolium</i>   | White Yarrow         | Perennial - herbaceous | Mix with grasses, cultivars Coronation Gold, Paprika, Sonoma Coast, MoonDust, | 3' x 3'                | Sun to Part-Shade | D                | L  | M   | Y                       |  |           | X                    | X                    | X      | X      | X                      | X              |          |                   | X            |
| <i>Baccharis pilularis</i> 'Twin Peaks'   | Dwarf Coyote Bush    | Groundcover - Woody    |   | 3'x12'                 | Sun to Part-Shade | E                | L  | L   | Y                       |  |           | x                    |                      |        |        | x                      |                | x        | x                 |              |
| <i>Carex barbarae</i>   | Santa Barbara Sedge  | Grass                  |   | 3' x 3'                | Sun to Part-Shade | E                | N/A                                      | M   | Y                       |  |           |                      |                      |        |        |                        |                |          |                   | X            |
| <i>Carex pansa</i>  | Dune Sedge           | Grass                  |   | 1' x 3'                | Sun to Shade      | E                | M  | M   | Y                       |  |           | X                    | X                    | X      | X      | X                      | X              |          |                   | X            |
| <i>Carex tumulicola</i> (C. divulsa)  | Dwarf Sedge          | Grass                  | Clumping sedge, workes well for bioswale slopes                               | 1' x 1-2'              | Shade to Part-Sun | E                | L  | M   | Y                       |  |           |                      |                      | X      | X      | X                      | X              |          |                   | X            |
| <i>Deschampsia cespitosa</i>  | Tufted Hair Grass    | Grass                  |   | 3' x 3'                | Sun               | D                | L  | L   | Y                       |  |           |                      |                      |        |        | X                      | X              |          |                   | X            |
| <i>Erigeron glaucus</i> 'Wayne Roderick'  | Wayne Roderick Daisy | Perennial - herbaceous |   | 0.5' x 0.7'            | Sun to Part-Shade | E                | L  | M   | Y                       |  |           |                      |                      |        |        |                        |                |          |                   | X            |
| <i>Erigeron karvinskianus</i>   | Santa Barbara Daisy  | Perennial - herbaceous |   | 1-2' x 3-5'            | Shade to Part-Sun | E                | L  | M   | Y                       |  |           | X                    | X                    | X      | X      | X                      |                |          |                   | X            |
| <i>Escholzia californica</i>  | California Poppy     | Wildflower             | Annual  | 1' x 1'                | Sun               | D                | VL                                       | M   | Y                       |  |           |                      |                      |        |        | X                      |                |          | X                 | X            |
| <i>Festuca rubra</i>  | Red Fescue           | Grass                  |   | 0.5' x 2'              | Part Shade to Sun | D                | L  | L   | Y                       |  |           |                      |                      |        |        |                        |                |          |                   | X            |
| <i>Grindelia stricta platyphylla</i>  | Coastal Gum Plant    | Perennial - herbaceous | Salt tolerant   | 2' x 4'                | Sun               | D                | L  | H   | Y                       |  |           |                      |                      |        |        |                        |                |          |                   | X            |
| <i>Helictotrichon sempervirens</i>  | Blue Oat Grass       | Grass                  |   | 2' x 3'                | Sun               | D                | L  | M   | Y                       |  |           |                      |                      |        |        |                        |                |          |                   | X            |
| <i>Iris douglasiana</i>   | Douglas Iris         | Perennial              |   | 2' x 4'                | Shade to Part-Sun | E                | L  | L   | Y                       |  |           |                      |                      |        |        |                        |                |          |                   | X            |
| <i>Juncus patens</i>  | Common Rush          | Grass                  |   | 3' x 2'                | Sun               | E                | L  | M   | Y                       |  |           |                      |                      |        |        |                        |                |          |                   | X            |
| <i>Muhlenbergia capillaris</i>  | Pink Muhly Grass     | Grass                  |   | 4' x 3'                | Sun               | E                | L  | M   | N                       | Eastern US                                     |           |                      |                      |        |        |                        |                |          |                   | X            |
| <i>Muhlenbergia rigens</i>  | Deergrass            | Grass                  |   | 4-5' x 4-6'            | Sun               | E                | L  | M   | Y                       |  |           |                      |                      |        | X      | X                      | X              |          |                   | X            |
| <i>Ranunculus californicus</i>  | California Buttercup | Herbaceous             | Small, Can be added to Carex's in Bioswales                                   | 3' x 3'                | Sun to Part-Shade | D                | VL                                       | M   | Y                       |  |           |                      |                      |        |        |                        |                |          |                   | X            |
| <i>Stipa pulchra</i>  | Purple Needle Grass  | Grass                  | Also Stipa lepida, Stipa cernua   | 2-3' x 1-2'            | Sun               | D                | VL                                       | M   | Y                       |  |           |                      |                      |        |        |                        |                |          | X                 | X            |



| UNDERSTORY: Comparison of RELM Guidelines and SCVURPPP Bioretention Understory         |                          |                     |   |                        |                   |                  |  |   |                         |  |           |                      |                      |        |        |                     |             |          |                |              |
|--|--------------------------|---------------------|---|------------------------|-------------------|------------------|--|---|-------------------------|--|-----------|----------------------|----------------------|--------|--------|---------------------|-------------|----------|----------------|--------------|
| LEGEND:  |                          |                     |   |                        |                   |                  |  |   |                         |  |           |                      |                      |        |        |                     |             |          |                |              |
| Orange = Understory in both SCVURPPP & VTA bioretention lists                          |                          |                     |   |                        |                   |                  |  |   |                         |  |           |                      |                      |        |        |                     |             |          |                |              |
| Blue = Understory in both lists, SCVURPPP as bioretention, VTA <b>not</b> bioretention |                          |                     |   |                        |                   |                  |  |   |                         |  |           |                      |                      |        |        |                     |             |          |                |              |
| Not highlighted = Understory not in SCVURPPP bioretention list                         |                          |                     |   |                        |                   |                  |  |   |                         |  |           |                      |                      |        |        |                     |             |          |                |              |
| Latin Name   | Common Name              | Plant Type          | Notes   | Mature Size<br>H' X W' | Sun / Shade       | Evrgm /<br>Decid | WATER<br>USE<br>WUCOLS<br>(San<br>Jose)* | Salt<br>Tolerance for<br>RCW<br>(H,M,L)** | Cali<br>Native<br>(Y/N) | Region of<br>Origin (if not<br>native to Cali) | TPOLOGIES | MAJOR<br>STREETSCAPE | MINOR<br>STREETSCAPE | PASEOS | PLAZAS | PASSIVE GREEN SPACE | PARKING LOT | RIPARIAN | SLOPE - BUFFER | BIORETENTION |
| <i>Syrinchium bellum</i>   | Blue-eyed Grass          | Perennial           | Mix with Grasses, Also <i>S. angustifolium</i> . <i>S. californicum</i> has yellow flwrs, M irrig needs | 1-1.5' x 0.5-2'        | Sun to Part-Shade | D                | L  | M   | Y                       |  |           | X                    | X                    | X      | X      |                     |             |          |                | X            |
| <i>Anigozanthus spp.</i>   | Kangaroo Paw             | Perennial           | Many cultivars are listed on SCVWD approved plant list Height and color vary.                           | 3' x 4'                | Sun               | E                | L  | M   | N                       | Australia                                      |           |                      | X                    | X      | X      | X                   |             |          |                |              |
| <i>Arctostaphylos 'Emerald Carpet'</i>   | Emerald Carpet Manzanita | Groundcover - Woody | Carmel Sur' or <i>A. uva ursi</i>   | 1.3' x 6'              | Sun to Part-Shade | E                | L  | M   | Y                       |  | X         |                      |                      |        | X      | X                   |             |          | X              |              |
| <i>Arctostaphylos densiflora</i>   | Vine Hill manzanita      | Shrub - med         | Howard McMinn' or 'Sentinel'  | 3' x 6'                | Sun-Part Shade    | E                | L  | M   | Y                       |  |           |                      |                      | X      | X      | X                   |             |          | X              |              |
| <i>Arctostaphylos hookeri</i>  | Hooker Manzanita         | Shrub - low         |   | 6' x 6'                | Sun to Part-Shade | E                | L  | M   | Y                       |  |           |                      |                      |        |        |                     |             |          | X              |              |
| <i>Aristida purpurea</i>   | Purple Three-awn         | Grass               | Can spread by seed, Warm Season   | 3' x 2'                | Sun               | D                | L  | M   | Y                       |  |           |                      |                      |        |        |                     |             |          |                |              |
| <i>Armeria maritima</i>  | Sea Pink                 | Perennial           |   | 1' x 1'                | Part Shade to Sun | E                | M  | L   | N                       | Mediterranean                                  | X         | X                    | X                    |        | X      |                     |             |          |                |              |
| <i>Bouteloua gracilis</i>  | Blue Gramma Grass        | Grass               | Blonde Ambition' or straight species. Warm Season, Winter Dormant                                       | 1.5' x 2'              | Sun               | D                | L  | H   | Y                       |  | X         | X                    | X                    | X      | X      | X                   |             |          |                |              |
| <i>Chondropetalum elephantium</i>  | Large Cape Rush          | Grass               |   | 5' x 10'               | Sun               | E                | L  | L   | N                       | South Africa                                   |           |                      | X                    |        | X      | X                   |             |          |                |              |
| <i>Chondropetalum tectorum</i>   | Small Cape Rush          | Grass               |   | 3' x 3'                | Sun               | E                | L  | M   | N                       | South Africa                                   |           |                      | X                    |        | X      | X                   |             |          |                |              |
| <i>Cistus ladanifer</i>  | Rockrose                 | Shrub - med - tall  |   | 6' x 5'                | Sun               | E                | L  | M   | N                       | Mediterranean                                  |           |                      | X                    |        | X      |                     |             |          |                |              |
| <i>Coreopsis grandiflora</i>   | Coreopsis                | Perennial           |   | 2' x 2'                | Sun               | D                | M  | L   | Y                       |  |           |                      |                      |        | X      |                     |             |          |                |              |
| <i>Dietes iridoides</i>  | Fortnight Lily           | Perennial           |   | 2' x 3'                | Sun to Part-Shade | E                | L  | M   | N                       | South Africa                                   | X         | X                    | X                    |        |        | X                   |             |          |                |              |
| <i>Echeveria spp.</i>  | Hens and Chicks          | Succulent           | Specialty Planters  | 0.7' x 0.7'            | Sun               | E                | L  | M   | N                       | South Africa                                   |           |                      | X                    | X      |        |                     |             |          |                |              |
| <i>Epilobium canum</i>   | California Fuchsia       | Perennial           | Also <i>Epilobium californica</i>   | 3' x 3'                | Sun to Part-Shade | D                | L  | M   | Y                       |  |           |                      |                      | X      | X      |                     |             |          | X              |              |
| <i>Eriogonum grande var. rubescens</i>   | Red-Flowered Buckwheat   | Perennial Sub-Shrub |   | 1.5' x 3'              | Wed               | E                | L  | M   | Y                       |  | X         |                      |                      |        |        |                     |             |          |                |              |
| <i>Eriogonum latifolium</i>  | Coast Buckwheat          | Perennial Sub-Shrub |   | 3' x 3'                | Thu               | E                | L  | M   | Y                       |  |           |                      |                      |        |        |                     |             |          | X              |              |



| UNDERSTORY: Comparison of RELM Guidelines and SCVURPPP Bioretention Understory         |                        |                                      |  |                        |                   |                   |  |   |                         |  |           |                   |                   |        |        |                     |             |          |                |              |
|--|------------------------|--------------------------------------|--|------------------------|-------------------|-------------------|--|---|-------------------------|--|-----------|-------------------|-------------------|--------|--------|---------------------|-------------|----------|----------------|--------------|
| LEGEND:  |                        |                                      |  |                        |                   |                   |  |   |                         |  |           |                   |                   |        |        |                     |             |          |                |              |
| Orange = Understory in both SCVURPPP & VTA bioretention lists                          |                        |                                      |  |                        |                   |                   |  |   |                         |  |           |                   |                   |        |        |                     |             |          |                |              |
| Blue = Understory in both lists, SCVURPPP as bioretention, VTA <b>not</b> bioretention |                        |                                      |  |                        |                   |                   |  |   |                         |  |           |                   |                   |        |        |                     |             |          |                |              |
| Not highlighted = Understory not in SCVURPPP bioretention list                         |                        |                                      |  |                        |                   |                   |  |   |                         |  |           |                   |                   |        |        |                     |             |          |                |              |
| Latin Name   | Common Name            | Plant Type                           | Notes  | Mature Size<br>H' X W' | Sun / Shade       | Evrgrn /<br>Decid | WATER<br>USE<br>WUCOLS<br>(San<br>Jose)* | Salt<br>Tolerance for<br>RCW<br>(H,M,L)** | Cali<br>Native<br>(Y/N) | Region of<br>Origin (if not<br>native to Cali) | TYPLOGIES | MAJOR STREETSCAPE | MINOR STREETSCAPE | PASEOS | PLAZAS | PASSIVE GREEN SPACE | PARKING LOT | RIPARIAN | SLOPE - BUFFER | BIORETENTION |
| <i>Festuca californica</i>   | California Fescue      | Grass                                | Salt tolerant  | 3' x 2'                | Sun to Shade      | D                 | L  | M   | Y                       |  |           |                   |                   |        |        |                     |             |          | X              |              |
| <i>Festuca idahoensis</i> 'Tomaes Bay'<br>(Elijah Blue)                                | Fescue Bunchgrass      | Grass                                |  | 1.5' x 1.5'            | Part Shade to Sun | D                 | VL                                       | M   | Y                       |  | X         | X                 | X                 | X      | X      |                     |             |          |                |              |
| <i>Fragaria chiloensis</i>   | Beach Strawberry       | Groundcover -<br>Herbaceous          |  | 1' x 3'                | Sun to Shade      | E                 | M  | M   | Y                       |  |           |                   |                   |        |        |                     |             |          | X              |              |
| <i>Fragaria vesca</i>  | Mountain Strawberry    | Groundcover -<br>Herbaceous          |  | 0.8' x 1.5'            | Shade to Part-Sun | E                 | M  | M   | Y                       |  |           |                   |                   |        |        |                     |             |          | X              |              |
| <i>Gaillardia grandiflora</i>  | Blanket Flower         | Perennial - herbaceous               |  | 2' x 1.2'              | Sun               | E                 | L  | M/H                                       | N                       | Texas  | X         |                   |                   |        |        |                     |             |          |                |              |
| <i>Garrya elliptica</i>  | Evie Silk Tassel Bush  | Shrub - tall                         | 'Evie', Garrya fremontii is another native species                           | 10' x 10'              | Sun               | E                 | L  | M   | Y                       |  |           |                   |                   |        |        |                     |             |          | X              |              |
| <i>Gaura lindheimeri</i>   | Gaura                  | Perennial - herbaceous               |  | 2' x 2'                | Sun               | D                 | M  | M   | N                       | Mediterranean                                  |           | X                 |                   | X      | X      |                     |             |          |                |              |
| <i>Grevelia</i> 'Moonlight' or other variety   |                        | Shrub - med                          |  | 12' x 8'               | Sun to Part-Shade | E                 | L  | M/H                                       | N                       | Australia                                      |           | X                 |                   | X      | X      |                     |             |          |                |              |
| <i>Heteromeles arbutifolia</i>   | Toyon                  | Shrub - tall                         |  | 10' x 8'               | Sun to Part-Shade | E                 | L  | M   | Y                       |  |           |                   |                   |        | X      |                     | X           | X        |                |              |
| <i>Heuchera maxima</i>   | Island Alumroot        | Perennial                            |  | 3' x 2'                | Shade to Part-Sun | E                 | M  | L   | Y                       |  |           |                   | X                 | X      | X      |                     |             |          | X              |              |
| <i>Monardella villosa</i>  | Coyote Mint            | Perennial                            |  | 1.5' x 3'              | Sun to Shade      | D                 | VL                                       | M   | Y                       |  |           |                   |                   |        |        |                     |             | X        |                |              |
| <i>Penstemon heterophyllus</i> 'Blue Springs'  | Foothill Penstemon     | Perennial                            |  | 2' x 1.5'              | Sun               | D                 | N/A                                      | M   | Y                       |  |           | X                 |                   | X      | X      | X                   |             |          | X              |              |
| <i>Phylla nodiflora</i>  | Lippia                 | Groundcover -<br>herbaceous          |  | 0.4' x 2'              | Sun to Part-Shade | E                 | N/A                                      | M   | N                       | Mediterranean                                  |           |                   |                   |        |        |                     | X           |          |                |              |
| <i>Ribes sanguineum glutinosum</i>   | Pink -Flowered Currant | Shrub - tall upright                 | moderate maintenance   | 12' x 12'              | Sun to Part-Shade | D                 | L  | L   | Y                       |  |           |                   | X                 |        | X      |                     |             | X        | X              |              |
| <i>Sedum spp.</i>  | Stonecrop              | Groundcover Succulent -<br>spreading |  | up to 3' x 3'          | Sun to Part-Shade | E                 | L  | M   | N                       | Mediterranean                                  |           |                   |                   |        |        |                     |             |          |                |              |
| <i>Symphoricarpos albus</i>  | Snowberry              | Shrub -low                           |  | 6' x 6'                | Shade to Part-Sun | E                 | L  | L   | Y                       |  |           |                   |                   |        |        |                     |             |          |                |              |
| <i>Verbena lilacina</i> 'De La Mina'   | De la Mina Lilac       | Perennial - mounding                 | low maintenance  | 2' x 3'                | Sun to Part-Shade | E                 | L  | M   | Y                       |  |           | X                 |                   | X      | X      | X                   |             |          |                |              |
| <i>Acmispon glaber</i>   | Deer Weed              | Perennial Sub-Shrub                  | Pioneer species, nitrogen fixer  | 2-3' x 2-3'            | Sun               | E                 | VL                                       | M   | Y                       |  |           |                   |                   |        |        |                     | X           | X        | X              | X            |
| <i>Artemisia californica</i>   | Sagebrush Prostrate    | Groundcover - Woody                  | 'Montara' / 'Canyon Grey' - will turn brown if not irrigated (eg. Berryessa) | 3-4' x 3-4'            | Sun               | E                 | L  | L   | Y                       |  |           |                   |                   | X      |        |                     |             |          |                | X            |
| <i>Artemisia douglasiana</i>   | Mugwort                | Perennial                            | Will take over plantbed  | 3' x 3'                | Sun to Part-Shade | D                 | L  | M   | Y                       |  |           |                   |                   |        |        |                     |             |          |                | X            |
| <i>Asclepias californica</i>   | California Milkweed    | Perennial                            | Habitat - Monarch  | 3' x 3'                | Sun               | D                 | L  | H   | Y                       |  |           |                   |                   |        |        |                     |             |          |                | X            |



| UNDERSTORY: Comparison of RELM Guidelines and SCVURPPP Bioretention Understory         |                         |                        |   |                        |                   |                  |  |   |                         |  |            |                      |                      |        |        |                     |             |          |                |              |  |  |  |  |  |  |  |  |  |  |  |  |  |  |
|--|-------------------------|------------------------|---|------------------------|-------------------|------------------|--|---|-------------------------|--|------------|----------------------|----------------------|--------|--------|---------------------|-------------|----------|----------------|--------------|--|--|--|--|--|--|--|--|--|--|--|--|--|--|
| LEGEND:  |                         |                        |   |                        |                   |                  |  |   |                         |  |            |                      |                      |        |        |                     |             |          |                |              |  |  |  |  |  |  |  |  |  |  |  |  |  |  |
| Orange = Understory in both SCVURPPP & VTA bioretention lists                          |                         |                        |   |                        |                   |                  |  |   |                         |  |            |                      |                      |        |        |                     |             |          |                |              |  |  |  |  |  |  |  |  |  |  |  |  |  |  |
| Blue = Understory in both lists, SCVURPPP as bioretention, VTA <b>not</b> bioretention |                         |                        |   |                        |                   |                  |  |   |                         |  |            |                      |                      |        |        |                     |             |          |                |              |  |  |  |  |  |  |  |  |  |  |  |  |  |  |
| Not highlighted = Understory not in SCVURPPP bioretention list                         |                         |                        |   |                        |                   |                  |  |   |                         |  |            |                      |                      |        |        |                     |             |          |                |              |  |  |  |  |  |  |  |  |  |  |  |  |  |  |
| Latin Name   | Common Name             | Plant Type             | Notes   | Mature Size<br>H' X W' | Sun / Shade       | Evrgm /<br>Decid | WATER<br>USE<br>WUCOLS<br>(San<br>Jose)* | Salt<br>Tolerance for<br>RCW<br>(H,M,L)** | Cali<br>Native<br>(Y/N) | Region of<br>Origin (if not<br>native to Cali) | TYPOLOGIES | MAJOR<br>STREETSCAPE | MINOR<br>STREETSCAPE | PASEOS | PLAZAS | PASSIVE GREEN SPACE | PARKING LOT | RIPARIAN | SLOPE - BUFFER | BIORETENTION |  |  |  |  |  |  |  |  |  |  |  |  |  |  |
| <i>Asclepias fascicularis</i>  | Narrow leaf milkweed    | Perennial              | Habitat - Monarch   | 3' x 1'                | Sun               | D                | L  | M   | Y                       |  |            |                      |                      |        |        |                     |             |          | X              | X            |  |  |  |  |  |  |  |  |  |  |  |  |  |  |
| <i>Asclepias speciosa</i>  | Showy Milkweed          | Perennial              | Habitat - Monarch   | 3' x 3'                | Sun               | D                | L  | M   | Y                       |  |            |                      |                      |        |        |                     |             |          |                | X            |  |  |  |  |  |  |  |  |  |  |  |  |  |  |
| <i>Baccharis glutinosa</i>   | Marsh Baccharis         | Perennial              | Salt Marsh Baccharis, only to be planted as part of Bioswale Mix              | 6' x 6'                | Sun               | E                | M  | M   | Y                       |  |            |                      |                      |        |        |                     |             |          |                | X            |  |  |  |  |  |  |  |  |  |  |  |  |  |  |
| <i>Bromus carinatus</i>  | California Brome        | Grass                  |   | 1-5' x 1-2'            | S                 | D                | L  | L   | Y                       |  |            |                      |                      |        |        |                     |             |          |                | X            |  |  |  |  |  |  |  |  |  |  |  |  |  |  |
| <i>Calamagrostis nutkaensis</i>  | Reed Grass              | Grass                  | Larger bunch grass, bottoms of bioswale basins                                | 3' x 3'                | Sun to Part-Shade | E                | M  | M   | Y                       |  |            |                      |                      |        |        | X                   |             |          |                | X            |  |  |  |  |  |  |  |  |  |  |  |  |  |  |
| <i>Calycanthus occidentalis</i>  | Western Spice Bush      | Shrub - med            | Good for Bioswale Height  | 8' x 20'               | Shade to Part-Sun | D                | M  | M   | Y                       |  |            |                      | X                    |        | X      |                     | X           |          |                | X            |  |  |  |  |  |  |  |  |  |  |  |  |  |  |
| <i>Carex nudata</i>  | Torrent Sedge           | Grass                  |   | 2.5' x 2'              | Sun to Part-Shade | E                | N/A                                      | H   | Y                       |  |            |                      |                      |        |        |                     |             |          |                | X            |  |  |  |  |  |  |  |  |  |  |  |  |  |  |
| <i>Carex praegracilis</i>  | Meadow Sedge            | Grass                  |   | 2' x 3'                | Sun to Shade      | E                | M  | M   | Y                       |  | X          | X                    | X                    | X      | X      | X                   |             |          |                | X            |  |  |  |  |  |  |  |  |  |  |  |  |  |  |
| <i>Dichelostemma capitatum</i>   | Bluedicks               | Bulb                   | Mix with Native Grasses and In Bioswales                                      | 1.5' - 2' x .5'        | Sun               | D                | VL                                       | M   | Y                       |  |            |                      |                      |        |        |                     |             |          |                | X            |  |  |  |  |  |  |  |  |  |  |  |  |  |  |
| <i>Elymus triticoides</i>  | Creeping Wildrye        | Grass                  | Lagunita' is a variety that has shorter leaves and typically does not flower. | 4' x 1'                | Sun               | D                | L  | M/H                                       | Y                       |  |            |                      |                      |        |        | X                   |             | X        | X              |              |  |  |  |  |  |  |  |  |  |  |  |  |  |  |
| <i>Euthamia occidentalis</i>   | Western Goldentop       | Perennial - herbaceous | Salt tolerant   | 2-5' x 2-6'            | Sun               | D                | N/A                                      | H   | Y                       |  |            |                      |                      |        |        |                     | X           | X        | X              |              |  |  |  |  |  |  |  |  |  |  |  |  |  |  |
| <i>Hordeum brachyantherum</i>  | Meadow Barley           | Grass                  |   | 2' x 1'                | Sun to Part-Shade | D                | N/A                                      | M   | Y                       |  |            |                      |                      |        |        |                     |             |          |                | X            |  |  |  |  |  |  |  |  |  |  |  |  |  |  |
| <i>Juncus effusus</i>  | Green Rush              | Grass                  |   | 4' x 1.5'              | Sun               | E                | M  | M   | Y                       |  |            |                      |                      |        |        |                     |             |          |                | X            |  |  |  |  |  |  |  |  |  |  |  |  |  |  |
| <i>Leymus condensatus 'Canyon Prince'</i>  | Canyon Prince Wild Rye  | Groundcover            |   | 4' x 4'                | Sun to Part-Shade | E                | L  | M/H                                       | Y                       |  |            |                      |                      |        |        | X                   |             | X        | X              |              |  |  |  |  |  |  |  |  |  |  |  |  |  |  |
| <i>Melica imperfecta</i>   | Coast Range Onion Grass | Grass                  |   | 1-3' x 2-3'            | Sun               | D                | VL                                       | M   | Y                       |  |            |                      |                      |        |        |                     | X           | X        | X              |              |  |  |  |  |  |  |  |  |  |  |  |  |  |  |
| <i>Muhlenbergia dubia</i>  | Pine Muhly Grass        | Grass                  |   | 3' x 4'                | Sun               | E                | L  | M   | N                       | Southwest US                                   | X          | X                    |                      |        | X      | X                   |             | X        | X              |              |  |  |  |  |  |  |  |  |  |  |  |  |  |  |
| <i>Penstemon centranthifolius</i>  | Scarlet Bugler          | Perennial              |   | 3' x 2'                | Sun               | D                | N/A                                      | M   | Y                       |  |            |                      |                      |        |        |                     |             |          |                | X            |  |  |  |  |  |  |  |  |  |  |  |  |  |  |
| <i>Sidalcea malviflora</i>   | Checkerbloom            | Perennial - herbaceous |   | 1' x 1'                | Part Shade to Sun | D                | M  | L   | Y                       |  |            |                      |                      |        |        |                     |             |          | X              | X            |  |  |  |  |  |  |  |  |  |  |  |  |  |  |
| <i>Solidago californica</i>  | California Goldenrod    | Perennial - herbaceous |   | 3' x 3'                | Sun               | D                | M  | M   | Y                       |  |            |                      |                      |        |        | X                   | X           |          |                | X            |  |  |  |  |  |  |  |  |  |  |  |  |  |  |
| <i>Sporobolus airoides</i>   | Alkali sacaton          | Grass                  | Tolerates Clay Soil, Tolerant of Salt Spray                                   | 4' x 3'                | Sun               | E                | L  | M/H                                       | Y                       |  |            |                      |                      |        |        |                     |             |          | X              | X            |  |  |  |  |  |  |  |  |  |  |  |  |  |  |



| UNDERSTORY: Comparison of RELM Guidelines and SCVURPPP Bioretention Understory         |                         |                        |   |                        |                   |                   |  |   |                         |  |            |                   |                   |        |        |                     |             |          |                |              |  |  |  |  |  |  |  |  |  |  |  |  |  |
|--|-------------------------|------------------------|---|------------------------|-------------------|-------------------|--|---|-------------------------|--|------------|-------------------|-------------------|--------|--------|---------------------|-------------|----------|----------------|--------------|--|--|--|--|--|--|--|--|--|--|--|--|--|
| LEGEND:  |                         |                        |   |                        |                   |                   |  |   |                         |  |            |                   |                   |        |        |                     |             |          |                |              |  |  |  |  |  |  |  |  |  |  |  |  |  |
| Orange = Understory in both SCVURPPP & VTA bioretention lists                          |                         |                        |   |                        |                   |                   |  |   |                         |  |            |                   |                   |        |        |                     |             |          |                |              |  |  |  |  |  |  |  |  |  |  |  |  |  |
| Blue = Understory in both lists, SCVURPPP as bioretention, VTA <b>not</b> bioretention |                         |                        |   |                        |                   |                   |  |   |                         |  |            |                   |                   |        |        |                     |             |          |                |              |  |  |  |  |  |  |  |  |  |  |  |  |  |
| Not highlighted = Understory not in SCVURPPP bioretention list                         |                         |                        |   |                        |                   |                   |  |   |                         |  |            |                   |                   |        |        |                     |             |          |                |              |  |  |  |  |  |  |  |  |  |  |  |  |  |
| Latin Name   | Common Name             | Plant Type             | Notes   | Mature Size<br>H' X W' | Sun / Shade       | Evrgrn /<br>Decid | WATER<br>USE<br>WUCOLS<br>(San<br>Jose)* | Salt<br>Tolerance for<br>RCW<br>(H,M,L)** | Cali<br>Native<br>(Y/N) | Region of<br>Origin (if not<br>native to Cali) | TYPOLOGIES | MAJOR STREETSCAPE | MINOR STREETSCAPE | PASEOS | PLAZAS | PASSIVE GREEN SPACE | PARKING LOT | RIPARIAN | SLOPE - BUFFER | BIORETENTION |  |  |  |  |  |  |  |  |  |  |  |  |  |
| <i>Abutilon palmeri</i>  | Indian Mallow           | Perennial Sub-Shrub    | Accent Shrub  | 3'-5' x3'-5'           | Sun               | E                 | L  | M   | Y                       |  |            |                   |                   |        | X      |                     |             |          | X              |              |  |  |  |  |  |  |  |  |  |  |  |  |  |
| <i>Acacia redolens</i>   | Prostrate Acacia        | Groundcover - Woody    | Non-Native, but tolerates slopes and no irrigation, Desert Carpet is cultivar   | 2' x 10-12'            | Sun               | E                 | VL                                       | H   | N                       | Australia                                      |            |                   |                   |        |        |                     |             |          |                |              |  |  |  |  |  |  |  |  |  |  |  |  |  |
| <i>Aeonium spp.</i>  | Aeonium                 | Succulent              | Specialty Planters  | up to 5' x 5'          |                   | E                 | L  | M   | N                       | South Africa                                   |            |                   | X                 | X      |        |                     |             |          |                |              |  |  |  |  |  |  |  |  |  |  |  |  |  |
| <i>Agastache rupestris</i>   | Licorice Mint           | Perennial - herbaceous |   | 3' x 1.5'              | Sun to Part-Shade | D                 | L  | M   | N                       | Southwest US                                   |            |                   |                   |        |        |                     |             |          |                |              |  |  |  |  |  |  |  |  |  |  |  |  |  |
| <i>Agave attenuata</i>   | Agave                   | Succulent              |   | 5' x 8'                | Sun               | E                 | L  | M   | N                       | Mexico   |            |                   | X                 | X      | X      |                     |             |          |                |              |  |  |  |  |  |  |  |  |  |  |  |  |  |
| <i>Agave Blue Glow</i>   | Blue Glow Century Plant | Succulent              |   | 2' x 3'                | Sun               | E                 | L  | L   | N                       | Mexico   |            |                   |                   | X      | X      |                     |             |          |                |              |  |  |  |  |  |  |  |  |  |  |  |  |  |
| <i>Agave spp.</i>  | Agave                   | Succulent              | many Agave species and cultivars are noted on SCVWD approved plant list and can be used as appropriate.                     | varies                 | Sun               | E                 | L  | M   | N                       | Mexico   |            |                   |                   |        |        |                     |             |          |                |              |  |  |  |  |  |  |  |  |  |  |  |  |  |
| <i>Aloe spp.</i>   | Aloe                    | Succulent              | many cultivars noted on SCVWD approved plant list and can be used as appropriate i.e. Aloe Vera, Aloe striata, Aloe nobilis | avg. 3' x 3'           | Sun to Part-Shade | E                 | L  | M   | N                       | South Africa                                   |            | X                 | X                 |        |        |                     |             |          |                |              |  |  |  |  |  |  |  |  |  |  |  |  |  |
| <i>Aquilegia formosa</i>   | Columbine               | Perennial              | Shade only, protected planters  | 3' x 1.5'              | Shade             | D                 | L  | M   | Y                       |  |            |                   | X                 | X      |        |                     |             |          |                |              |  |  |  |  |  |  |  |  |  |  |  |  |  |
| <i>Arbutus unedo multi-stem</i>  | Strawberry Madrone      | Shrub - tall           | Fruit   | 15' x 15'              | Sun-Part Shade    | E                 | L  | M   | N                       | Mediterranean                                  |            |                   |                   |        | X      |                     |             | X        |                |              |  |  |  |  |  |  |  |  |  |  |  |  |  |
| <i>Arctostaphylos 'Pacific Mist'</i>   | Pacific Mist Manzanita  | Groundcover - Woody    |   | 2' x 8'                | Sun to Part-Shade | E                 | L  | L   | Y                       |  | X          | X                 |                   |        | X      | X                   |             | X        |                |              |  |  |  |  |  |  |  |  |  |  |  |  |  |
| <i>Arctostaphylos bakeri 'Louis Edmunds'</i>   | Bakers Manzanita        | Shrub - med            |   | 6' x 6'                | Sun               | E                 | L  | L   | Y                       |  |            |                   |                   |        |        |                     |             | X        |                |              |  |  |  |  |  |  |  |  |  |  |  |  |  |
| <i>Arctostaphylos glauca</i>   | Big Berry Manzanita     | Shrub - tall           |   | 20' x 20'              | Sun               | E                 | L  | M   | Y                       |  |            |                   |                   |        |        |                     |             |          |                |              |  |  |  |  |  |  |  |  |  |  |  |  |  |
| <i>Arctostaphylos John Dourley</i>   | John Dourley Manzanita  | John Dourley Manzanita | Shrub - Low, spreading, reddish leaves and bark.  | 2' x 6'                | Sun               | E                 | L  | M   | Y                       |  |            |                   |                   |        |        |                     |             |          |                |              |  |  |  |  |  |  |  |  |  |  |  |  |  |
| <i>Arctostaphylos manzanita</i>  | Manzanita               | Shrub - tall           | Specimen shrub, Dr Hurd' / 'St Helena' / 'Austin Griffiths' well draining soil  | 20' x 10'              | Sun               | E                 | L  | M   | Y                       |  |            |                   |                   |        | X      |                     |             |          |                |              |  |  |  |  |  |  |  |  |  |  |  |  |  |
| <i>Arctostaphylos pumila 'Wavelength'</i>  | SandMat Manzanita       | Shrub - med            | Mounding shrub,   | 3' x 15'               | Sun to Part-Shade | E                 | L  | L   | Y                       |  |            |                   |                   |        |        |                     |             |          |                |              |  |  |  |  |  |  |  |  |  |  |  |  |  |
| <i>Arctostaphylos refugioensis</i>   | Refugio Manzanita       | Shrub - med            |   | 13' x 7'               | Sun               | E                 | L  | M   | Y                       |  |            |                   |                   |        |        |                     |             |          |                |              |  |  |  |  |  |  |  |  |  |  |  |  |  |
| <i>Arctostaphylos stanfordiana</i>   | Stanford Manzanita      | Shrub - med            | Mounding shrub  | 7' x 6'                | Sun               | E                 | L  | M   | Y                       |  |            |                   |                   |        |        |                     |             |          | X              |              |  |  |  |  |  |  |  |  |  |  |  |  |  |
| <i>Aristolochia californica</i>  | Dutchman's Pipe         | Vine                   | Pipevine SwallowTail Host, Excellent climber up Gabions   | 20' x 20'              | Shade             | D                 | N/A                                      | L/M                                       | Y                       |  |            |                   |                   |        |        | X                   |             | X        |                |              |  |  |  |  |  |  |  |  |  |  |  |  |  |
| <i>Baileya multiradiata</i>  | Desert marigold         | Perennial              | Fall blooming yellow flowers  | 1.6' x 1'              | Sun               | D                 | L  | M   | Y                       |  |            |                   |                   |        |        |                     |             |          |                |              |  |  |  |  |  |  |  |  |  |  |  |  |  |



| UNDERSTORY: Comparison of RELM Guidelines and SCVURPPP Bioretention Understory         |                                  |                    |  |                        |                   |                  |  |   |                         |  |           |                      |                      |        |        |                     |             |          |                |              |
|--|----------------------------------|--------------------|--|------------------------|-------------------|------------------|--|---|-------------------------|--|-----------|----------------------|----------------------|--------|--------|---------------------|-------------|----------|----------------|--------------|
| LEGEND:  |                                  |                    |  |                        |                   |                  |  |   |                         |  |           |                      |                      |        |        |                     |             |          |                |              |
| Orange = Understory in both SCVURPPP & VTA bioretention lists                          |                                  |                    |  |                        |                   |                  |  |   |                         |  |           |                      |                      |        |        |                     |             |          |                |              |
| Blue = Understory in both lists, SCVURPPP as bioretention, VTA <b>not</b> bioretention |                                  |                    |  |                        |                   |                  |  |   |                         |  |           |                      |                      |        |        |                     |             |          |                |              |
| Not highlighted = Understory not in SCVURPPP bioretention list                         |                                  |                    |  |                        |                   |                  |  |   |                         |  |           |                      |                      |        |        |                     |             |          |                |              |
| Latin Name   | Common Name                      | Plant Type         | Notes  | Mature Size<br>H' X W' | Sun / Shade       | Evrgm /<br>Decid | WATER<br>USE<br>WUCOLS<br>(San<br>Jose)* | Salt<br>Tolerance for<br>RCW<br>(H,M,L)** | Cali<br>Native<br>(Y/N) | Region of<br>Origin (if not<br>native to Cali) | TYPLOGIES | MAJOR<br>STREETSCAPE | MINOR<br>STREETSCAPE | PASEOS | PLAZAS | PASSIVE GREEN SPACE | PARKING LOT | RIPARIAN | SLOPE - BUFFER | BIORETENTION |
| <i>Berberis aquifolium var. repens</i>   | Creeping Oregon Grape            | Groundcover -Woody | Shade  | 2.5' x 5'              | Shade to Part-Sun | D                | L  | M   | Y                       |  |           |                      | X                    |        | X      |                     |             | X        |                |              |
| <i>Berberis pinnata ssp. Insularis</i>   | California Barberry              | Shrub - med        | Many cultivars have spiny leaves.  | 10' x10'               | Shade to Part-Sun | D                | M  | L   | Y                       |  |           |                      | X                    |        | X      |                     |             | X        |                |              |
| <i>Brodiaea californica</i>  | California Brodiaea              | Bulb               | Mix with Native Grasses and In Bioswales                                       | 1.5' - 2' x .5'        | Sun               | D                | L  | L   | Y                       |  |           |                      |                      |        |        |                     |             |          | X              |              |
| <i>Bulbine frutescens</i>  | Bulbine                          | Succulent          |  | 1.5' x 3'              | Sun to Part-Shade | E                | L  | M   | N                       | South Africa                                   |           | X                    | X                    |        | X      |                     |             |          |                |              |
| <i>Calochortus luteus</i>  | Golden Mariposa                  | Bulb               | Specialty Planter under Oaks   | 1' x .5'               | Shade to Part-Sun | D                | L  | H   | Y                       |  |           |                      |                      |        | X      |                     |             |          | X              |              |
| <i>Calylophus drummondiana, berlandieri, Hartwegii</i>                                 | Texas Primrose, Sierra Sundrop   | Perennial          | low groundcover massing  | 2' x 2'                | Sun               | D                | L  | M   | N                       | Southwest US                                   |           | X                    | X                    | X      | X      | X                   |             |          |                |              |
| <i>Carex spissa</i>  | San Diego Sedge                  | Grass              | Can get very large   | 4' x 4'                | Sun to Part-Shade | E                | M  | M   | Y                       |  |           |                      |                      |        |        |                     |             |          |                |              |
| <i>Carpenteria californica</i>   | Bush Anemone                     | Shrub - tall       | Best in part shade. Will have some yellow leaves year-round, but still healthy | 8' x 5'                | Shade to Part-Sun | E                | M  | M   | Y                       |  |           |                      | X                    |        | X      |                     |             |          |                |              |
| <i>Ceanothus 'Ray Hartman'</i>   | Ray Hartman California Lilac     | Shrub - tall       |  | 30' x 10'              | Sun               | E                | L  |   | Y                       |  |           |                      |                      |        | X      |                     |             |          | X              |              |
| <i>Ceanothus maritimus 'Valley Violet'</i>   | Valley Violet Maritime Ceanothus | Shrub - low        |  | 3' x 5'                | Sun to Part-Shade | E                | L  | M   | Y                       |  | X         | X                    |                      | X      | X      | X                   |             |          | X              |              |
| <i>Ceanothus thyrsiflorus var. griseus</i>   | Carmel Ceanothus                 | Shrub - med        | mounding shrub   | 15' x 15'              | Sun               | E                | L  | M   | Y                       |  |           |                      |                      |        |        | X                   |             |          | X              |              |
| <i>Ceanothus thysiflorus 'Variety TBD'</i>   | California Lilac                 | Shrub - tall       | Oregon Mist, Concha or other variety   | 15' x 15'              | Sun               | E                | L  | M   | Y                       |  |           |                      |                      |        | X      |                     |             |          | X              |              |
| <i>Cercocarpus betuloides</i>  | Mountain Mahogany                | Shrub - tall       | Needs well draining soil   | 20' x 12'              | Sun               | E                | VL                                       | M   | Y                       |  |           |                      |                      |        | X      |                     |             |          | X              |              |
| <i>Chaenomeles speciosa</i>  | Flowering Quince                 | Shrub -tall        | Fruiting, Orange flowers in Jan/Feb  | 10' x 12'              |                   | D                | L  | L   | N                       | Mediterranean                                  |           |                      |                      |        | X      | X                   |             |          | X              |              |
| <i>Cistus salvifolius prostratus</i>   | Sageleaf Rockrose                | Groundcover        |  | 2' x 6'                | Sun to Part-Shade | E                | L  | M   | N                       | Mediterranean                                  |           | X                    | X                    |        | X      | X                   |             |          |                |              |
| <i>Clarkia unguiculata</i>   | Elegant Clarkia                  | Wildflower         | Annual, C. rubicunda also appropriate  | 3' x 3'                | Sun               | D                | N/A                                      | M   | Y                       |  |           |                      |                      |        |        |                     |             |          | X              |              |
| <i>Clematis ligustifolia</i>   | Clematis                         | Vine               | Also C. armandii,  | up to 30' x 6'         | Sun to Part Shade | D                | M  | L   | Y                       |  |           |                      |                      |        |        |                     |             |          | X              |              |
| <i>Collinsia heterophylla</i>  | Chinese Houses                   | Wildflower         | Annual   | 1.6' x 4'              | Shade             | D                | N/A                                      | M   | Y                       |  |           |                      |                      |        |        |                     |             |          | X              |              |
| <i>Corylus cornuta ssp. Californica</i>  | Hazelnut                         | Shrub -tall        | Small Tree   | 7'-7'                  | Shade             | D                | M  | M   | Y                       |  |           | X                    | X                    |        | X      |                     | X           |          |                |              |
| <i>Daphne x transatlantica</i>   | Dapne                            | Shrub - med        | Evergreen shrub with white flowers, drought tolerant                           | 3' x 3'                | Sun to Part-Shade | E                | L  | M   | N                       | Asia   |           |                      |                      |        |        |                     |             |          |                |              |



| UNDERSTORY: Comparison of RELM Guidelines and SCVURPPP Bioretention Understory  |                           |                     |   |                        |                   |                   |  |   |                         |  | TYPES | MAJOR STREETS | MINOR STREETS | PASEOS | PLAZAS | PASSIVE GREEN SPACE | PARKING LOT | RIPARIAN | SLOPE - BUFFER | BIORETENTION |  |
|---|---------------------------|---------------------|---|------------------------|-------------------|-------------------|--|---|-------------------------|--|-------|---------------|---------------|--------|--------|---------------------|-------------|----------|----------------|--------------|--|
| Latin Name  | Common Name               | Plant Type          | Notes   | Mature Size<br>H' X W' | Sun / Shade       | Evrgrn /<br>Decid | WATER<br>USE<br>WUCOLS<br>(San<br>Jose)* | Salt<br>Tolerance for<br>RCW<br>(H,M,L)** | Cali<br>Native<br>(Y/N) | Region of<br>Origin (if not<br>native to Cali) |       |               |               |        |        |                     |             |          |                |              |  |
| LEGEND:   |                           |                     |   |                        |                   |                   |  |   |                         |  |       |               |               |        |        |                     |             |          |                |              |  |
| Orange = Understory in both SCVURPPP & VTA bioretention lists                   |                           |                     |   |                        |                   |                   |  |   |                         |  |       |               |               |        |        |                     |             |          |                |              |  |
| Blue = Understory in both lists, SCVURPPP as bioretention, VTA not bioretention |                           |                     |   |                        |                   |                   |  |   |                         |  |       |               |               |        |        |                     |             |          |                |              |  |
| Not highlighted = Understory not in SCVURPPP bioretention list                  |                           |                     |   |                        |                   |                   |  |   |                         |  |       |               |               |        |        |                     |             |          |                |              |  |
| <i>Dasyliirion wheeleri</i>   | Desert spook              | Succulent           |   | 5' x 5'                | Sun               | E                 | L  | M   | N                       | Southwest US                                   |       |               |               |        | X      | X                   |             |          |                |              |  |
| <i>Dendromecon hardfordii</i>   | Bush Poppy                | Shrub - med         |   | 15' x 15'              | Sun to Part-Shade | E                 | L  | L   | Y                       |  |       |               |               |        | X      |                     | X           | X        |                |              |  |
| <i>Diplacus aurantiacus</i>   | Bush Monkey Flower        | Perennial Sub-Shrub |   | 4' x 3'                | Sun to Part-Shade | E                 | L  | M   | Y                       |  |       |               |               |        |        |                     |             |          | X              |              |  |
| <i>Dryopteris arguta</i>  | Coastal Woodfern          | Fern                | Under Oaks  | 2' x 2'                | Partial           | E                 | M  | L   | Y                       |  |       |               |               |        |        |                     |             |          |                |              |  |
| <i>Elymus glaucus</i>   | Blue Wildrye              | Grass               |   | 5' x 1'                | Sun to Part-Shade | D                 | N/A                                      | M/H                                       | Y                       |  |       |               |               |        |        |                     |             |          |                | X            |  |
| <i>Encelia Californica</i>  | California Bush Sunflower | Perennial Sub-Shrub |   | 4' x 5'                | Sun to Part-Shade | D                 | L  | M   | Y                       |  |       |               |               |        | X      |                     |             | X        |                |              |  |
| <i>Ericameria ericoides</i>   |                           | Perennial Sub-Shrub |   | 3' x 4'                | Sun               | D                 | L  | M/H                                       | Y                       |  |       |               |               |        |        |                     |             |          |                | X            |  |
| <i>Eriogonum fasciculatum</i>   | California Buckwheat      | Perennial Sub-Shrub |   | 6' x 3'                | Mon               | E                 | VL                                       | M   | Y                       |  |       |               |               |        |        |                     |             |          |                | X            |  |
| <i>Eriogonum giganteum</i>  | Saint Catherine's Lace    | Perennial Sub-Shrub |   | 5' x 10'               | Tue               | E                 | L  | M   | Y                       |  |       |               |               |        |        |                     |             |          |                | X            |  |
| <i>Eriogonum nudum</i>  | Naked Buckwheat           | Perennial Sub-Shrub |   | 1' x 0.6'              | Fri               | E                 | L  | M   | Y                       |  |       | X             |               |        | X      | X                   | X           |          |                |              |  |
| <i>Eriogonum umbellatum</i>   | Sulfur Buckwheat          | Perennial Sub-Shrub |   | 2' x 1'                | Sat               | E                 | L  | M   | Y                       |  |       | X             |               |        | X      | X                   | X           | X        |                |              |  |
| <i>Fallugia paradoxa</i>  | Apache Plume              | Perennial Sub-Shrub |   | 4' x 4'                | Sun               | D                 | L  | H   | Y                       |  |       |               |               |        | X      |                     |             |          | X              |              |  |
| <i>Feijoa sellowiana</i>  | Pinapple Guava            | Shrub - tall        |   | 15' x 15'              | Sun               | E                 | N/A                                      | M   | N                       | Mediterranean                                  |       |               |               | X      | X      |                     |             |          |                |              |  |
| <i>Ficus pumila</i>   | Creeping Fig              | Vine                | Evergreen, clinging vine. Use sparingly as screen plant where needed. | 15' x 6'               | Sun               | E                 | M  | M   | N                       | Asia   |       |               |               |        |        |                     |             |          |                |              |  |
| <i>Fremontodendron californica</i>  | Flannel Bush              | Shrub - tall        |   | 20' x 20'              | Sun               | D                 | VL                                       | M/H                                       | Y                       |  |       |               |               |        | X      |                     | X           | X        |                |              |  |
| <i>Geranium sanguineum</i>  | Cranesbill                | Groundcover         |   | 1' x 2'                | Shade             | D                 | M  | L   | N                       | Mediterranean                                  |       |               |               | X      | X      |                     |             |          |                |              |  |
| <i>Gilia capita</i>   | Gumplant                  | Wildflower          | Annual  | 2' x 2'                | Sun               | D                 | L  | M   | Y                       |  |       |               |               |        |        |                     |             |          |                | X            |  |
| <i>Helianthemum nummularium</i><br><i>'Henfield Brilliant'</i>                  | Sunrose                   | Grouncover          |   | 0.7' x 2'              | Part Shade to Sun | E                 | L  | H   | N                       | Mediterranean                                  |       |               | X             | X      |        |                     |             |          |                | X            |  |
| <i>Helianthus californicus</i>  | California Sunflower      | Wildflower          | Salt tolerant   | 5' x 10'               | Sun               | D                 | L  | M   | Y                       |  |       |               |               |        | X      |                     |             |          | X              |              |  |
| <i>Hesperaloe pavifolia</i>   | Red Yucca                 | grass               |   | 4' x 6'                | Sun               | E                 | L  | M/H                                       | Y                       |  |       |               |               | X      | X      | X                   |             |          |                |              |  |



| UNDERSTORY: Comparison of RELM Guidelines and SCVURPPP Bioretention Understory         |                          |                        |  |                        |                   |                   |  |   |                         |  |           |                      |                      |        |        |                     |             |          |                |              |  |  |  |  |  |  |  |  |  |  |  |  |  |
|--|--------------------------|------------------------|--|------------------------|-------------------|-------------------|--|---|-------------------------|--|-----------|----------------------|----------------------|--------|--------|---------------------|-------------|----------|----------------|--------------|--|--|--|--|--|--|--|--|--|--|--|--|--|
| LEGEND:  |                          |                        |  |                        |                   |                   |  |   |                         |  |           |                      |                      |        |        |                     |             |          |                |              |  |  |  |  |  |  |  |  |  |  |  |  |  |
| Orange = Understory in both SCVURPPP & VTA bioretention lists                          |                          |                        |  |                        |                   |                   |  |   |                         |  |           |                      |                      |        |        |                     |             |          |                |              |  |  |  |  |  |  |  |  |  |  |  |  |  |
| Blue = Understory in both lists, SCVURPPP as bioretention, VTA <b>not</b> bioretention |                          |                        |  |                        |                   |                   |  |   |                         |  |           |                      |                      |        |        |                     |             |          |                |              |  |  |  |  |  |  |  |  |  |  |  |  |  |
| Not highlighted = Understory not in SCVURPPP bioretention list                         |                          |                        |  |                        |                   |                   |  |   |                         |  |           |                      |                      |        |        |                     |             |          |                |              |  |  |  |  |  |  |  |  |  |  |  |  |  |
| Latin Name   | Common Name              | Plant Type             | Notes  | Mature Size<br>H' X W' | Sun / Shade       | Evrgrn /<br>Decid | WATER<br>USE<br>WUCOLS<br>(San<br>Jose)* | Salt<br>Tolerance for<br>RCW<br>(H,M,L)** | Cali<br>Native<br>(Y/N) | Region of<br>Origin (if not<br>native to Cali) | TPOLOGIES | MAJOR<br>STREETSCAPE | MINOR<br>STREETSCAPE | PASEOS | PLAZAS | PASSIVE GREEN SPACE | PARKING LOT | RIPARIAN | SLOPE - BUFFER | BIORETENTION |  |  |  |  |  |  |  |  |  |  |  |  |  |
| <i>Hesperoyucca whipplei</i>   | Chaparral Yucca          | Succulent              |  | 9' x 9'                | Sun               | E                 | L  | M/H                                       | N                       | South Africa                                   |           |                      |                      |        | X      | X                   |             |          |                | X            |  |  |  |  |  |  |  |  |  |  |  |  |  |
| <i>Heuchera micrantha</i>  | Crevice Alumroot         | Perennial - herbaceous |  | 1-3' x 1'              | Shade             | E                 | M  | L   | Y                       |  |           |                      |                      |        |        |                     |             |          |                |              |  |  |  |  |  |  |  |  |  |  |  |  |  |
| <i>Holodiscus discolor</i>   | Creambush                | Shrub - med            |  | 9' x 6'                | Shade             | E                 | L  | M   | Y                       |  |           |                      |                      |        | X      |                     |             |          |                | X            |  |  |  |  |  |  |  |  |  |  |  |  |  |
| <i>Iris 'Canyon Snow'</i>  | Canyon Snow Pacific Iris | Perennial              |  | 1.5' x 3'              | Shade to Part-Sun | E                 | L  | L   | Y                       |  | X         | X                    | X                    |        | X      |                     |             |          |                |              |  |  |  |  |  |  |  |  |  |  |  |  |  |
| <i>Ixia spp.</i>   | African Corn Lily        | Bulb                   |  | 1' x 1'                | Sun to Part Shade | D                 | N/A                                      | M   | N                       | South Africa                                   | X         | X                    | X                    | X      |        |                     |             |          |                |              |  |  |  |  |  |  |  |  |  |  |  |  |  |
| <i>Jasmine nudiflorum</i>  | Winter Jasmine           | Vine                   |  | 12' x 4'               | Sun to Part Shade | D                 | L  | L   | N                       | Asia   |           |                      | X                    | X      | X      |                     |             |          |                |              |  |  |  |  |  |  |  |  |  |  |  |  |  |
| <i>Jasmine officiale f. grandiflorum</i>   | Common Jasmine           | Vine                   |  | 4' x 7'                | Sun to Part Shade | D                 | L  | L   | N                       | Asia   |           |                      | X                    |        | X      |                     |             |          |                |              |  |  |  |  |  |  |  |  |  |  |  |  |  |
| <i>Keckiella cordifolia</i>  | Red Hot Pokers           | Shrub - low            | Under Oaks                                   | 6' x 6'                | Shade             | D                 | L  | M   | Y                       |  |           |                      |                      |        | X      |                     |             |          |                | X            |  |  |  |  |  |  |  |  |  |  |  |  |  |
| <i>Kniphofia uvaria hybrids</i>  | Red Hot Poker            | Succulent              | Prefers some fog                             | 3' x 3'                | Sun to Part Shade | E                 | L  | M/H                                       | N                       | South Africa                                   |           |                      | X                    | X      | X      |                     |             |          |                |              |  |  |  |  |  |  |  |  |  |  |  |  |  |
| <i>Lavandula spp. 'Goodwin Creek Grey'</i>   | Lavender                 | Perennial Sub-Shrub    |  | 3' x 4'                | Sun to Part-Shade | E                 | L  | M   | N                       | Mediterranean                                  |           | X                    |                      | X      | X      |                     |             |          |                |              |  |  |  |  |  |  |  |  |  |  |  |  |  |
| <i>Lavandula stoechas 'Otto Quast'</i>   | Spanish Lavender         | Perennial Sub-Shrub    |  | 3' x 3'                | Sun to Part-Shade | E                 | L  | M   | N                       | Mediterranean                                  |           | X                    |                      | X      | X      |                     |             |          |                |              |  |  |  |  |  |  |  |  |  |  |  |  |  |
| <i>Lavatera maritima</i>   | Bush Mallow              | Perennial Sub-Shrub    |  | 8' x 12'               | Sun to Part-Shade | D                 | L  | M/H                                       | Y                       |  |           |                      |                      |        |        |                     |             |          |                | X            |  |  |  |  |  |  |  |  |  |  |  |  |  |
| <i>Lepechinia calycina</i>   | Pitcher Sage             | Perennial Sub-Shrub    |  | 8' x 6'                | Shade             | D                 | L  | L   | Y                       |  |           |                      | X                    | X      | X      |                     |             |          |                |              |  |  |  |  |  |  |  |  |  |  |  |  |  |
| <i>Lessingia felaginifolia</i>   | California Dune Aster    | Groundcover/Annual     |  | 0.3' x 8'              | Sun to Part-Shade | E                 | L  | M   | Y                       |  |           |                      |                      |        | X      |                     |             |          |                | X            |  |  |  |  |  |  |  |  |  |  |  |  |  |
| <i>Leucojum aestivum</i>   | Summer Snowflake         | Bulb                   | Can add to streetscapes to enhance diversity | 1.5' - 2' x .5'        | Sun               | D                 | M  | L   | N                       | Mediterranean                                  |           | X                    | X                    |        | X      |                     |             |          |                |              |  |  |  |  |  |  |  |  |  |  |  |  |  |
| <i>Limonium perezii</i>  | Statice                  | Perennial              |  | 3' x 3'                | Sun to Part-Shade | E                 | L  | M/H                                       | N                       | Mediterranean                                  | X         | X                    | X                    |        |        |                     |             |          |                |              |  |  |  |  |  |  |  |  |  |  |  |  |  |
| <i>Lonicera hispidula</i>  | California Honeysuckle   | Vine                   |  | 18'x 10'               | Sun to Part Shade | D                 | L  | M   | Y                       |  |           |                      | X                    |        | X      |                     |             | X        | X              |              |  |  |  |  |  |  |  |  |  |  |  |  |  |
| <i>Lupinus albifrons</i>   | Silver Bush Lupine       | Perennial Sub-Shrub    |  | 2' x 5'                | Sun               | D                 | VL                                       | M   | Y                       |  |           |                      |                      |        | X      |                     |             |          |                | X            |  |  |  |  |  |  |  |  |  |  |  |  |  |
| <i>Malacothamnus fasciculatus</i>  | Bush Mallow              | Perennial Sub-Shrub    |  | 15' x 10'              | Sun               | E                 | VL                                       | M   | Y                       |  |           |                      |                      | X      | X      |                     |             |          |                | X            |  |  |  |  |  |  |  |  |  |  |  |  |  |
| <i>Melaleuca armillaris</i>  | Bracelet Honey-Myrtle    | Shrub - tall           |  | 15-30' x 15-30'        | Sun               | E                 | VL                                       | M/H                                       | N                       | Australia                                      |           |                      |                      |        | X      |                     |             |          |                |              |  |  |  |  |  |  |  |  |  |  |  |  |  |



| UNDERSTORY: Comparison of RELM Guidelines and SCVURPPP Bioretention Understory         |                        |                     |  |                        |                   |                   |  |   |                         |  |            |                      |                      |        |        |                     |             |          |                |              |  |  |  |  |  |  |  |  |  |  |  |  |  |
|--|------------------------|---------------------|--|------------------------|-------------------|-------------------|--|---|-------------------------|--|------------|----------------------|----------------------|--------|--------|---------------------|-------------|----------|----------------|--------------|--|--|--|--|--|--|--|--|--|--|--|--|--|
| LEGEND:  |                        |                     |  |                        |                   |                   |  |   |                         |  |            |                      |                      |        |        |                     |             |          |                |              |  |  |  |  |  |  |  |  |  |  |  |  |  |
| Orange = Understory in both SCVURPPP & VTA bioretention lists                          |                        |                     |  |                        |                   |                   |  |   |                         |  |            |                      |                      |        |        |                     |             |          |                |              |  |  |  |  |  |  |  |  |  |  |  |  |  |
| Blue = Understory in both lists, SCVURPPP as bioretention, VTA <b>not</b> bioretention |                        |                     |  |                        |                   |                   |  |   |                         |  |            |                      |                      |        |        |                     |             |          |                |              |  |  |  |  |  |  |  |  |  |  |  |  |  |
| Not highlighted = Understory not in SCVURPPP bioretention list                         |                        |                     |  |                        |                   |                   |  |   |                         |  |            |                      |                      |        |        |                     |             |          |                |              |  |  |  |  |  |  |  |  |  |  |  |  |  |
| Latin Name   | Common Name            | Plant Type          | Notes  | Mature Size<br>H' X W' | Sun / Shade       | Evrgrn /<br>Decid | WATER<br>USE<br>WUCOLS<br>(San<br>Jose)* | Salt<br>Tolerance for<br>RCW<br>(H,M,L)** | Cali<br>Native<br>(Y/N) | Region of<br>Origin (if not<br>native to Cali) | TYPOLOGIES | MAJOR<br>STREETSCAPE | MINOR<br>STREETSCAPE | PASEOS | PLAZAS | PASSIVE GREEN SPACE | PARKING LOT | RIPARIAN | SLOPE - BUFFER | BIORETENTION |  |  |  |  |  |  |  |  |  |  |  |  |  |
| <i>Melaleuca decussata</i>   | Totem Poles            | Shrub - tall        |  | 8-2' x 8-20'           | Sun               | E                 | VL                                       | M/H                                       | N                       | Australia                                      |            |                      |                      |        | X      |                     |             |          |                |              |  |  |  |  |  |  |  |  |  |  |  |  |  |
| <i>Myoporum parvifolium</i>  | Myoporum               | Groundcover/Shurb   |  | 1' x 10'               | Sun               | E                 | L  | M   | N                       | Australia                                      |            |                      |                      |        |        |                     |             |          |                |              |  |  |  |  |  |  |  |  |  |  |  |  |  |
| <i>Myrtus communis compacta</i>  | Dwarf Myrtle           | Shrub - med         | hedge  | 2-4' x 2-4'            | Sun               | E                 | L  | M   | N                       | Australia                                      |            |                      | X                    | X      |        | X                   |             |          |                |              |  |  |  |  |  |  |  |  |  |  |  |  |  |
| <i>Nolina microcarpa</i>   | Bear Grass             | Grass               | Also N. nelsonii                                 | 5' x 7'                | Sun               | E                 | VL                                       | M/H                                       | Y                       |  |            |                      |                      |        |        |                     |             |          |                |              |  |  |  |  |  |  |  |  |  |  |  |  |  |
| <i>Olea europea 'Little Ollie'</i>   | Dwarf Olive            | Shrub - Med         |  | 6' x 6'                | Sun to Part-Shade | E                 | VL                                       | M   | N                       | Mediterranean                                  |            |                      | X                    | X      | X      | X                   |             |          |                |              |  |  |  |  |  |  |  |  |  |  |  |  |  |
| <i>Origanum dictamnus and other species</i>  | Oreganos               | Perennial/Annual    |  | 1' x 3'                | Part Shade to Sun | E                 | M  | L   | N                       | Mediterranean                                  |            | X                    |                      |        |        |                     |             |          |                |              |  |  |  |  |  |  |  |  |  |  |  |  |  |
| <i>Oxalis oregana</i>  | Redwood Sorrel         | Groundcover         |  | 1.3' x 6'              | Shade             | D                 | M  | L   | Y                       |  |            |                      |                      |        | X      |                     |             |          |                |              |  |  |  |  |  |  |  |  |  |  |  |  |  |
| <i>Parthenocissus tricuspidata</i>   | Virginia Creeper       | Vine                | Can use P. vitaveae or P. henryaba as well       | up to 50' x 10'        | Sun to Part Shade | D                 | L  | M   | N                       | North America                                  |            |                      | X                    |        |        |                     |             |          |                |              |  |  |  |  |  |  |  |  |  |  |  |  |  |
| <i>Phacelia californica</i>  | Scorpion Flower        | Wildflower          | Slopes and Under Oaks, Good Habitat              | 1' x 1.5'              | Sun to Part Shade | D                 | L  | M   | Y                       |  |            |                      |                      |        |        |                     |             |          | X              |              |  |  |  |  |  |  |  |  |  |  |  |  |  |
| <i>Phlomis lanata</i>  | Jerusalem Sage         | Perennial Sub-Shrub |  | 2' x 6'                | Sun               | E                 | L  | M   | N                       | Mediterranean                                  |            | X                    | X                    | X      | X      |                     |             |          |                |              |  |  |  |  |  |  |  |  |  |  |  |  |  |
| <i>Phormium tenax</i>  | New Zealand Flax       | Perennial           | ?  | 2' x 3'                | Sun               | E                 | L  | M/H                                       | N                       | New Zealand                                    |            |                      | X                    |        | X      | X                   |             |          |                |              |  |  |  |  |  |  |  |  |  |  |  |  |  |
| <i>Physocarpus capitatus</i>   | Ninebark               | Shrub - tall        |  | 13' x 7'               | Shade to Part-Sun | D                 | L  | L   | Y                       |  |            |                      |                      |        |        |                     |             |          | X              |              |  |  |  |  |  |  |  |  |  |  |  |  |  |
| <i>Podocarpus henkelii</i>   | Long Leafed Yellowwood | Shrub - tall        |  | 30' x 25'              | Sun to Part-Shade | E                 | M  | L   | N                       | Asia   |            |                      | X                    | X      | X      |                     |             |          |                |              |  |  |  |  |  |  |  |  |  |  |  |  |  |
| <i>Polypodium californicum</i>   | Polypody Fern          | Fern                | Under Oaks, P. scouleri is also good species     | 1' x 1'                | Shade to Part-Sun | E                 | VL                                       | L   | Y                       |  |            |                      | X                    |        |        |                     |             |          | X              |              |  |  |  |  |  |  |  |  |  |  |  |  |  |
| <i>Polystichum munitum</i>   | Western Sword Fern     | Fern                | Under Oaks                                       | 2' x 2'                | Shade             | E                 | M  | L   | Y                       |  |            |                      | X                    | X      | X      |                     |             |          |                |              |  |  |  |  |  |  |  |  |  |  |  |  |  |
| <i>Prunus ilicifolia</i>   | Holly Leaf Cherry      | Shrub-tall          |  | 30' x 25'              | Sun to Part-Shade | E                 | L  | L   | Y                       |  |            |                      |                      |        |        |                     |             |          |                |              |  |  |  |  |  |  |  |  |  |  |  |  |  |
| <i>Quercus berberidifolia</i>  | Scrub Oak              | Shrub - tall        | Available at native plant nurseries, plant small | 15' x 12'              | Sun to Part-Shade | E                 | VL                                       | M   | Y                       |  |            |                      |                      |        |        |                     |             | X        | X              |              |  |  |  |  |  |  |  |  |  |  |  |  |  |
| <i>Quercus durata</i>  | Leather Oak            | Shrub - tall        | Available at native plant nurseries, plant small | 9' x 6'                | Sun to Part-Shade | E                 | VL                                       | M   | Y                       |  |            |                      |                      |        |        |                     |             | X        | X              |              |  |  |  |  |  |  |  |  |  |  |  |  |  |
| <i>Rhamnus californica</i>   | Coffeeberry            | Shrub - med - tall  | Eve Case', Mound San Bruno, Leather leaf,        | 3-6' x 3-65'           | Sun to Part-Shade | E                 | L  | M   | Y                       |  |            |                      | X                    |        | X      | X                   | X           | X        | X              |              |  |  |  |  |  |  |  |  |  |  |  |  |  |
| <i>Rhus integrifolia (ovata)</i>   | Lemonadeberry          | Shrub - tall        |  | 25' x 25'              | Sun               | E                 | L  | M   | Y                       |  |            |                      |                      |        |        | X                   |             | X        |                |              |  |  |  |  |  |  |  |  |  |  |  |  |  |



| UNDERSTORY: Comparison of RELM Guidelines and SCVURPPP Bioretention Understory         |                       |                        |  |                        |                   |                   |  |   |                         |  |           |                      |                      |        |        |                     |             |          |                |              |
|--|-----------------------|------------------------|--|------------------------|-------------------|-------------------|--|---|-------------------------|--|-----------|----------------------|----------------------|--------|--------|---------------------|-------------|----------|----------------|--------------|
| LEGEND:  |                       |                        |  |                        |                   |                   |  |   |                         |  |           |                      |                      |        |        |                     |             |          |                |              |
| Orange = Understory in both SCVURPPP & VTA bioretention lists                          |                       |                        |  |                        |                   |                   |  |   |                         |  |           |                      |                      |        |        |                     |             |          |                |              |
| Blue = Understory in both lists, SCVURPPP as bioretention, VTA <b>not</b> bioretention |                       |                        |  |                        |                   |                   |  |   |                         |  |           |                      |                      |        |        |                     |             |          |                |              |
| Not highlighted = Understory not in SCVURPPP bioretention list                         |                       |                        |  |                        |                   |                   |  |   |                         |  |           |                      |                      |        |        |                     |             |          |                |              |
| Latin Name   | Common Name           | Plant Type             | Notes  | Mature Size<br>H' X W' | Sun / Shade       | Evrgrn /<br>Decid | WATER<br>USE<br>WUCOLS<br>(San<br>Jose)* | Salt<br>Tolerance for<br>RCW<br>(H,M,L)** | Cali<br>Native<br>(Y/N) | Region of<br>Origin (if not<br>native to Cali) | TPOLOGIES | MAJOR<br>STREETSCAPE | MINOR<br>STREETSCAPE | PASEOS | PLAZAS | PASSIVE GREEN SPACE | PARKING LOT | RIPARIAN | SLOPE - BUFFER | BIORETENTION |
| <i>Ribes aureum</i>  | Golden Currant        | Shrub - tall           |  | 3.5' x 3.5'            | Shade             | D                 | N/A                                      | L   | Y                       |  |           |                      |                      |        | X      |                     | X           | X        |                |              |
| <i>Ribes malvaceum</i>   | Chaparral Currant     | Shrub - tall           |  | 6' x 6'                | Shade             | D                 | VL                                       | L   | Y                       |  |           |                      |                      |        | X      |                     | X           | X        |                |              |
| <i>Ribes viburnifolium</i>   | Evergreen Currant     | Shrub - low            |  | 4' x 6'                | Shade to Part-Sun | E                 | L  | M   | Y                       |  |           | X                    | X                    |        | X      |                     |             | X        |                |              |
| <i>Rosa californica</i>  | California Wild Rose  | Shrub                  | Spreads !  | 3' x 9'                | Sun to Part-Shade | E                 | L  | M   | Y                       |  |           |                      |                      |        |        |                     | X           | X        |                |              |
| <i>Rosemarinus officinalis</i><br>'Huntington's Carpet'                                | Creeping Rosemary     | Groundcover - Woody    | Mediterranean, Drought Tolerant, Low Maintenance               | 1.5' x 1.5'            | Sun to Part-Shade | E                 | L  | M   | N                       | Mediterranean                                  |           | X                    | X                    |        | X      | X                   |             | X        |                |              |
| <i>Rosmarinus officinalis</i> 'Tuscan Blue'  | Rosemary              | Shrub - med            | Count  | 4' x 2'                | Sun to Part-Shade | E                 | L  | M   | N                       | Mediterranean                                  |           | X                    |                      |        | X      | X                   |             | X        |                |              |
| <i>Rubus parviflorus</i>   | Thimbleberry          | Vine - Shrub           | Can be invasive  | 8' x 6'                | Sun to Part Shade | D                 | L  | M   | Y                       |  |           |                      |                      |        |        |                     |             | X        |                |              |
| <i>Salvia apiana</i>   | White Sage            | Perennial Sub-Shrub    |  | 4.5' x 4.5'            | Sun               | D                 | VL                                       | M   | Y                       |  |           |                      |                      |        | X      |                     |             | X        |                |              |
| <i>Salvia clevelandii</i>  | Cleveland Sage        | Perennial Sub-Shrub    |  | 4.5' x 4.5'            | Sun to Part-Shade | E                 | L  | M   | Y                       |  |           |                      |                      |        | X      | X                   |             |          |                |              |
| <i>Salvia greggii</i>  | Autumn Sage           | Perennial Sub-Shrub    |  | 3' x 3'                | Sun to Part-Shade | E                 | L  | M/H                                       | N                       | Mexico   |           |                      | X                    | X      | X      |                     |             |          |                |              |
| <i>Salvia leucophylla</i> 'Bee's Bliss'  | Bee's Bliss Sage      | Groundcover Shrub      |  | 2' x 8'                | Sun               | E                 | L  | M   | Y                       |  | X         |                      |                      |        |        | X                   |             | X        |                |              |
| <i>Salvia spathacea</i>  | Hummingbird Sage      | Groundcover Perennial  |  | 2' x 5'                | Shade to Part-Sun | E                 | L  | M   | Y                       |  |           | X                    | X                    |        | X      |                     |             | X        |                |              |
| <i>Santolina chamaecyparissus</i>  | Dwarf Lavender Cotton | Perennial - herbaceous |  | 2' x 4'                | Sun               | E                 | L  | H   | N                       | Mediterranean                                  |           | X                    |                      |        |        |                     |             |          |                |              |
| <i>Satureja douglasii</i>  | Yerba Buena           | Perennial              |  | 0.5' x 0.5'            | Shade to Part-Sun | E                 | L  | M   | Y                       |  |           |                      |                      |        |        |                     |             | X        |                |              |
| <i>Scrophularia californica</i>  | Bee Plant             | Perennial Sub-Shrub    |  | 4' x 12'               | Partial           | D                 | L  | L   | Y                       |  |           |                      |                      |        |        |                     |             | X        |                |              |
| <i>Senecio serpens</i>   | Blue Chalk Sticks     | Succulent              | Can be used as added 'filler' in more desert themed plant beds | 1' x 3'                | Sun to Part-Shade | E                 | L  | M   | N                       | South Africa                                   |           |                      | X                    | X      | X      | X                   |             |          |                |              |
| <i>Sesleria autumnalis</i>   | Moor Grass            | Grass                  |  | 1' x 1'                | Sun to Part-Shade | E                 | M  | M/H                                       | N                       | Mediterranean                                  |           | X                    | X                    |        | X      | X                   | X           |          |                |              |
| <i>Spharalcea munroana</i>   | Orange Globe Mallow   | Perennial Sub-Shrub    |  | 2.5' x 2'              | Sun               | E                 | L  | M   | Y                       |  |           |                      | X                    | X      | X      |                     |             |          |                |              |
| <i>Tagetes lemmonii</i>  | Mexican Marigold      | Perennial Sub-Shrub    |  | 4-6' x 6'              | Sun               | E                 | L  | H   | Y                       |  |           |                      |                      | X      | X      | X                   |             |          |                |              |
| <i>Teucrium chamaedrys</i>   | Wall Germander        | Groundcover Perennial  |  | 1' x 2-3'              | Sun               | E                 | L  | H   | N                       | Mediterranean                                  |           | X                    | X                    |        | X      | X                   |             |          |                |              |



**ATTACHMENT C:**  
VTA IRRIGATION GUIDELINES

## VTA DESIGNATED MATCHING PRODUCTS (DMP) LIST

Designated Matching Product (DMP) are a set of VTA-accepted products and materials for use in a contract or procurement package. DMPs are designated by manufacturer's brand or trade name. DMPs are used in order to match other products in use on a particular public improvement either completed or in the course of completion.

Instructions to Designer: Whenever a DMP<sup>1</sup> is included in a contract or procurement package, the designer shall verify with manufacturer that product is still available. Verify if product is still compliant with applicable regulations including Buy America requirements for Federally-funded projects. If product information is out-of-date or otherwise incorrect, do the following: Designer shall inform VTA Project Manager and recommend an alternative product for approval; VTA personnel shall inform VTA Group responsible for item.

| Name of Item                    | Product Specification   |
|---------------------------------|---|
| Satellite Irrigation Controller | Jain-ET Water SmartBox Model 205W-XX (xx = Number of Stations from 8 to 48 stations are available, refer to <a href="https://jainsusa.com/etwater/controller/">https://jainsusa.com/etwater/controller/</a> and product information attached. |
| Controller Housing and Pedestal | ETWater appropriate pedestal. For outdoor locations: Brushed stainless steel heavy- duty weatherproof and vandal-resistant enclosure with lockable, hinged and gasketed door. Includes antenna.   |
| Controller Protection           | Jain-ETWater appropriate Transient Surge Arrestor (AC line protection). Install in the controller enclosure. Correctly ground for lightning protection as required for each controller.   |
| Water Flow Meter                | Jain-ETWater appropriate, line-mounted paddle wheel impeller type of corrosion resistant construction.  |

**VTA standard is cellular based communication with a 5-year data plan.**



Jain is a fully integrated global food / plant production company recognized by Harvard Business to be one of five global sustainability champions, the G-20 for lifting people out of poverty, and Fortune magazine for being a "Change the World Company." Our irrigation manufacturing capabilities include everything from behind the pump to the flush valve at the end of the lateral and everything in between. We lead the industry in manufacturing technology, owning both our extrusion and mold manufacturing equipment providers.

Jain leads plant science research globally across a variety of food crops and is staffed with some of the world's leading research scientists. With the Gandhi Library, Jain now houses the leading collection of the world's best plant science knowledge in a single facility. Our agronomic knowledge is integrated from our world class plant tissue culture operations through our food processing businesses. We research, educate, advance, manufacture, finance, propagate plants, and purchase produce for processing all in an effort to fulfill the Jain mission:

**"Leave This World Better Than You Found It"**

**Jain Irrigation, Inc.**

[www.jainsusa.com](http://www.jainsusa.com)

**Jain Customer Service**

Phone: (559) 485-7171

Fax: (800) 777-6162

**Western Manufacturing Facility**

2851 E. Florence Ave.

Fresno, CA 93721

**Northeastern Manufacturing Facility**

740 Water St.

Watertown, NY 13601

**ETwater Corporate Offices**

6 Hamilton Landing Suite 175

Novato, CA 94949



Please recycle after use.

AG-011 6/19 © 2019 Jain Irrigation, Inc. All rights reserved.



# ETWATER CONTROLLERS



World Leader in Irrigation Technology





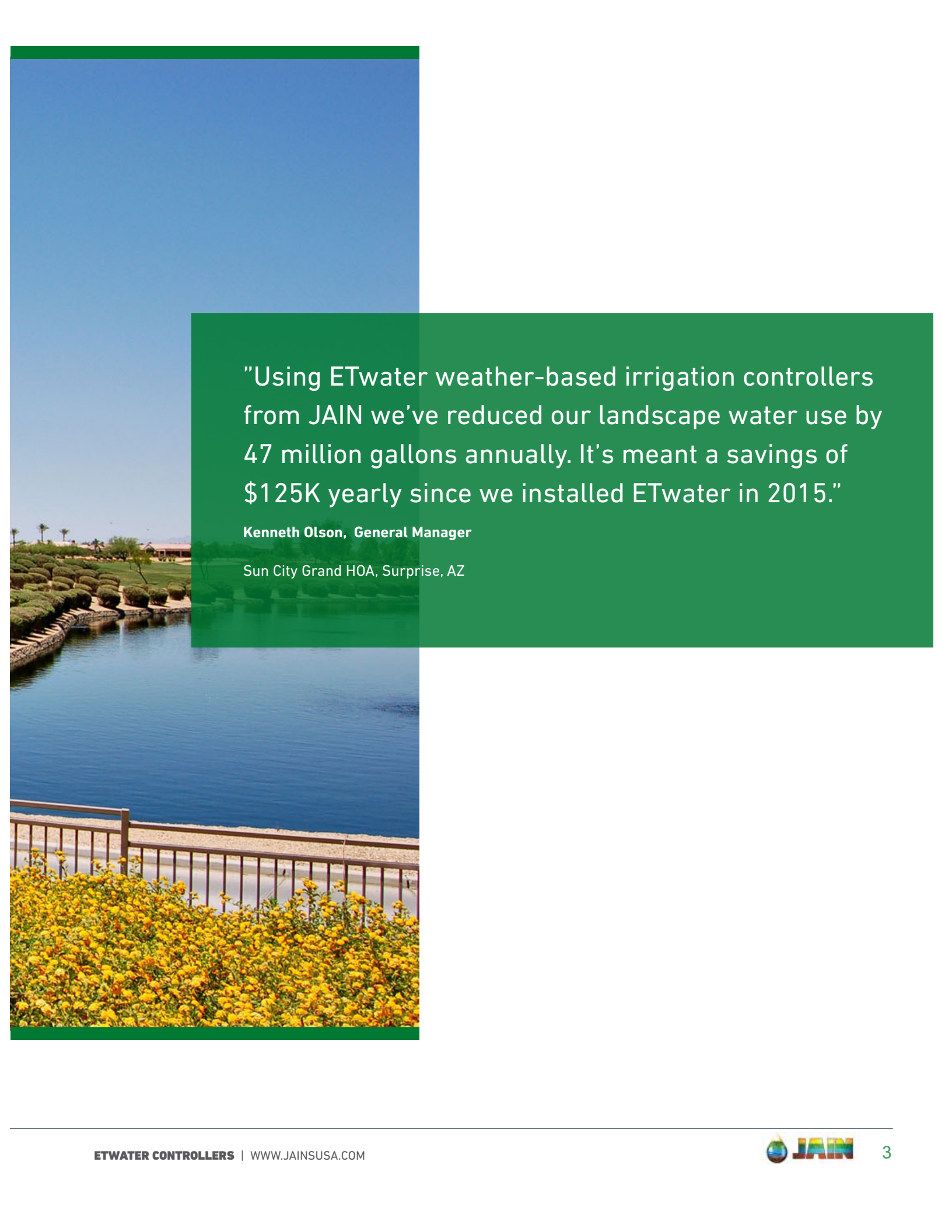

"Using ETwater weather-based irrigation controllers from JAIN we've reduced our landscape water use by 47 million gallons annually. It's meant a savings of \$125K yearly since we installed ETwater in 2015."

**Kenneth Olson, General Manager**

Sun City Grand HOA, Surprise, AZ

# How ETwater Controllers Work

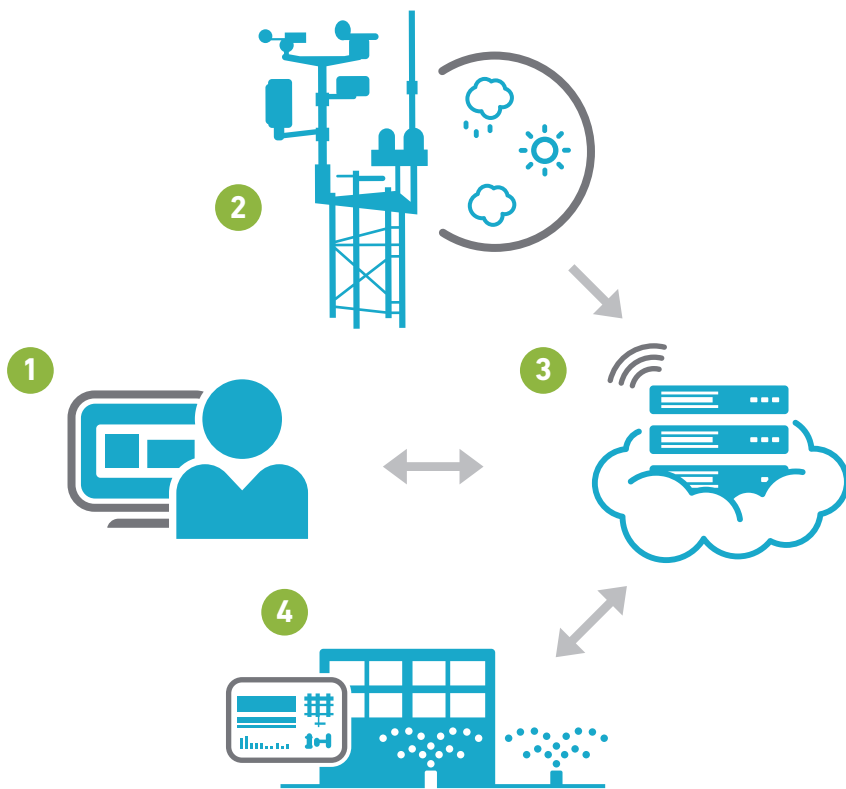

1. Use the ETwater Manager online management system to set up your account by entering your landscape profiles. Then, install the ETwater smart controller.
2. Microclimate forecasts localized to latitude / longitude coordinates and cross-referenced to an exclusive hourly historical weather database.
3. ETwater servers access the weather data, compute evapotranspiration, and generate daily watering schedules for each landscape profile. Servers then connect wirelessly to ETwater smart controllers to exchange schedules and data.
4. ETwater smart controllers execute daily irrigation schedules.

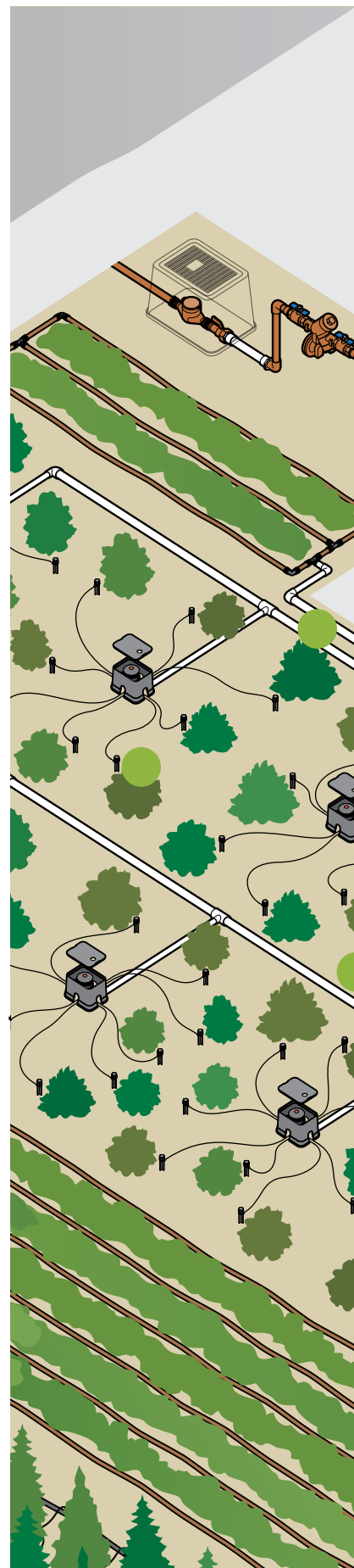

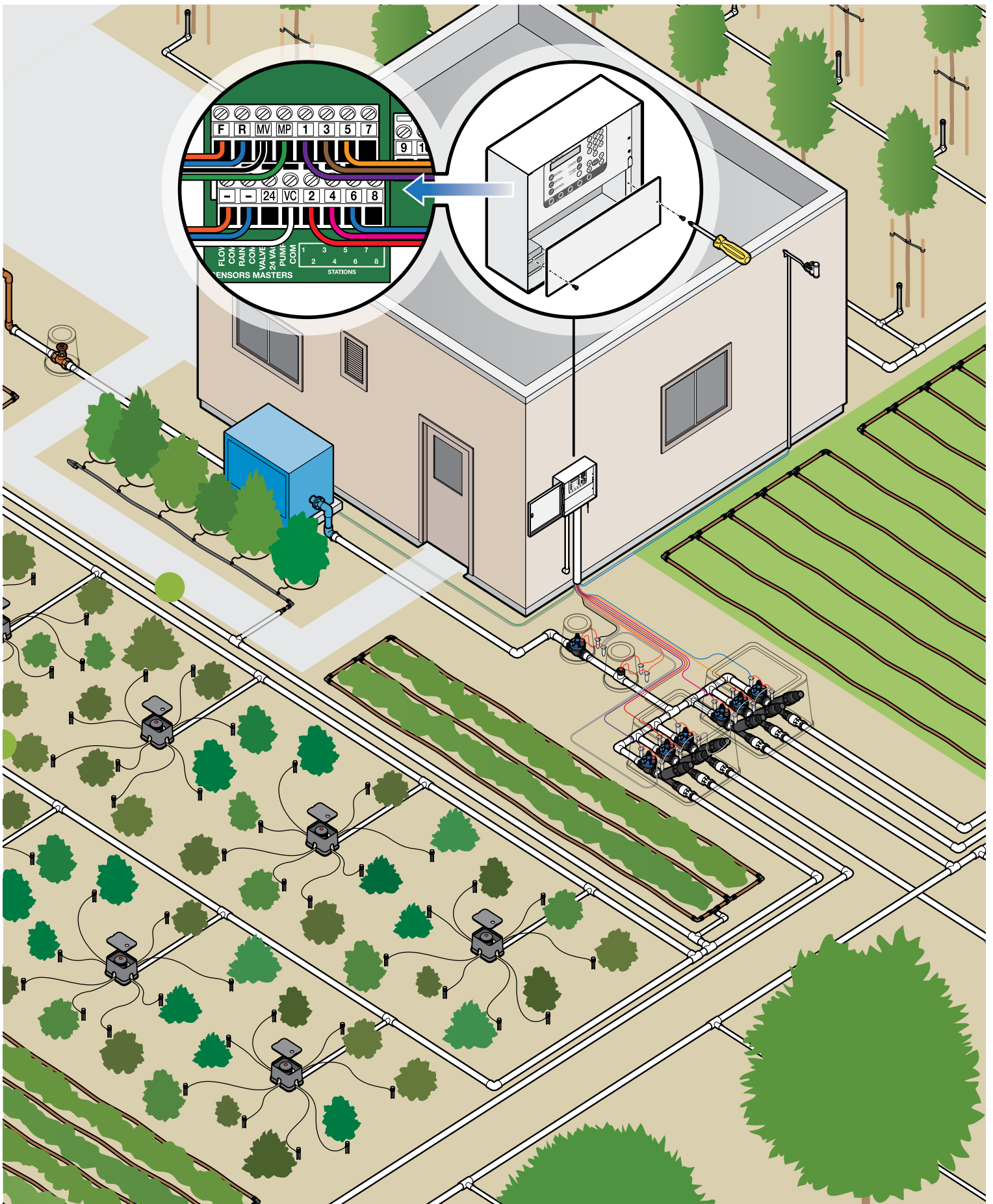

# SmartBox

## Product Features

- Durable, weather resistant aluminum enclosure with locking cabinet for indoor or outdoor use
- Suitable for wall mounting and selected pedestal installations
- Manual operation of individual stations or all stations (*from 1-255 minutes in 1 minute increments*)
- Backlit display for viewing programs and manual valve operation
- Plug in interface for RainMaster remotes
- Connections for rain sensor, booster pump, master valve and flow sensor. Compatible with normally open or normally closed master valves and rain/freeze or wind sensors.
- Email alerts sent in the event of a station short or flow alarm
- EPA WaterSense certified.
- Made in the USA



## SmartBox Includes

- SmartBox controller is available in 8 station increments up to 48 stations
- Chassis mounted grounding lug for added lightning protection
- 120 VAC input and 24VAC output
- All 24VAC output terminals have surge protection rated up to 4KV in accordance with IEC 6100-4-5 standard
- All outputs protected by a 2.0 amp self resetting fuse
- Input power draw: 1.0 amp or less at 120 volts VAC
- Total controller output is 2.0 amps
- Non-volatile memory
- 3 year controller limited warranty
- FCC approved

## Electrical Specifications

### SmartBox Model 205

- Station Capacity 8, 16, 24, 32, 40 or 48
- Dimensions 14.5" W x 12.5" H x 4.75" D
- Weight 10 lbs
- Wireless Communication

### Optional Accessories

- Covert antenna
- Universal Remote Adapter



8 Station Wiring Board

#### SmartBox Model Numbers

|         |                                 |
|---------|---------------------------------|
| 205W-8  | 8 Station Model 205 Controller  |
| 205W-16 | 16 Station Model 205 Controller |
| 205W-24 | 24 Station Model 205 Controller |
| 205W-32 | 32 Station Model 205 Controller |
| 205W-40 | 40 Station Model 205 Controller |
| 205W-48 | 48 Station Model 205 Controller |

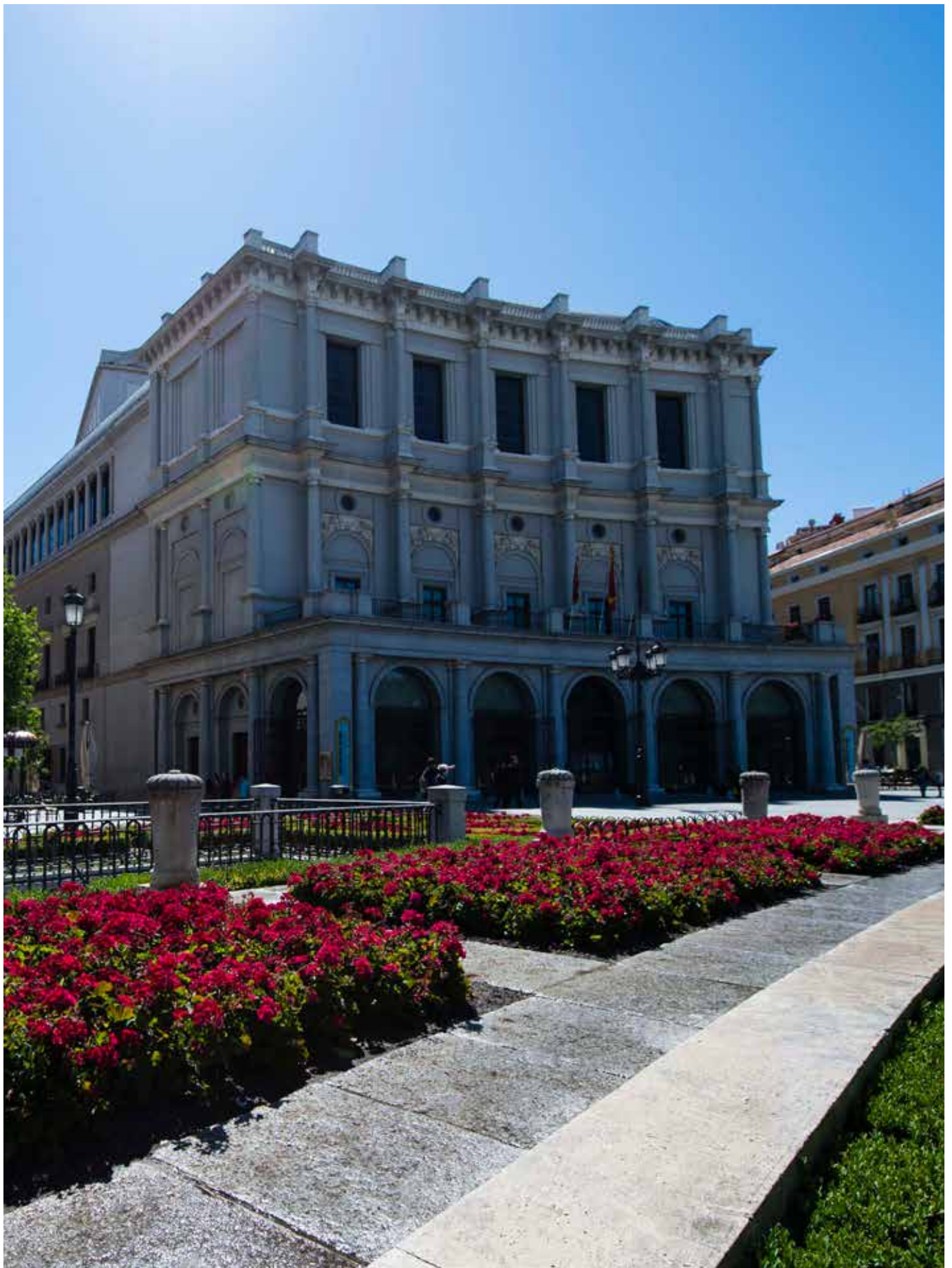

# ETwater Manager

## Remote Management and Monitoring

- Weather-based watering schedules with ET and rain adjustments automatically generated each day for all stations, virtually eliminating overwatering and runoff
- At-A-Glance Dashboard aggregates information from all sites, accounts or controllers under management onto one screen, making site management remote and simple
- Manage Groups feature allows for quick changes to hundreds of stations simultaneously
- Advanced water budgeting tool provides information necessary to make budgetary adjustments
- Email alerts of interruptions in watering schedules provide site knowledge and allow for quick response
- Customized graphs and reports provide visibility into site performance and water usage
- Weather forecast feature incorporates forecasted rain fall into schedules, suspending irrigation *before* it rains
- Advanced customization is available, such as user-defined fixed watering schedules, user-defined water windows, establishment schedules and adjustable depletion levels
- Secure password protected access lets multiple users view and / or manage each account. View-only access is also available





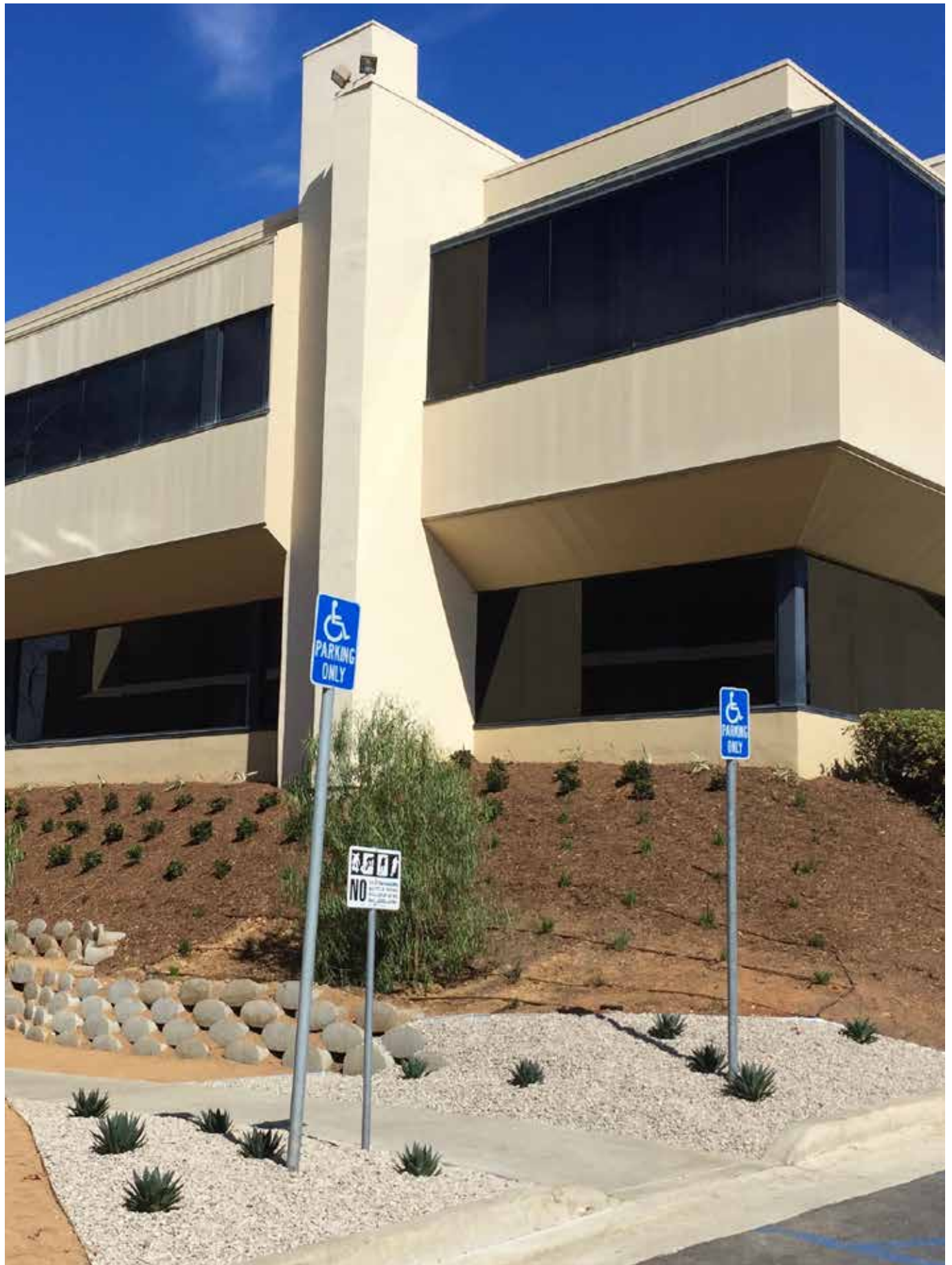



**ATTACHMENT D:**  
SWCP TEMPLATES



## **ATTACHMENT D:**

### **D1: SWCP TEMPLATE FOR SMALL PROJECTS**



## Stormwater Control Plan for Small Projects

### Instructions

This Stormwater Control Plan (SWCP) template for the project:

---

---

is to be used as a guide for compliance with Section F.5.g.1 of the Phase II Small MS4 General Permit. As a Permittee, VTA is required to implement measures for runoff reduction for all development and redevelopment projects that create and/or replace 2,500 to 5,000 square feet or more of impervious surface (Small Projects).

A registered Professional Engineer (P.E.) must complete this SWCP. The template must be filled out during the planning stages of the project. Complete the form on last page of this document and submit a SWCP that includes the following:

- Project Data Form & Project Setting
- Design strategies to limit disturbance (if applicable)
- Completed Runoff Reduction Checklists
- SMARTS or OWP LID screenshots of completed Post-Construction Water Balance (or equivalent)
- Site Plan Drawings and supporting details and specifications
- O&M Plan for runoff reduction measures
- Explanation of Runoff Reduction Installation Infeasibility (if applicable)
- Completed VTA Signoff for Stormwater and Landscaping Design



**STEP 1:** Complete all fields of the Project Data Form.

| Project Data Form   |   |
|---|---|
| Project Name/Number   |   |
| Application Submittal Date<br>[to be verified by VTA staff] |   |
| Date Design Initiated<br>[to be verified by VTA staff]      |   |
| Project Approval Date<br>[to be verified by VTA staff]      |   |
| Project Location  |   |
| Name of Owner or Developer                                  |   |
| Project Type and Description                                |   |
| Total Project Site Area                                     | <u>Acres</u>  |
| Total Pre-Project Impervious Surface Area                   | <u>Square Feet</u>                                  |
| Total Post-Project Impervious Surface Area                  | <u>Square Feet</u>                                  |
| Total New or Replaced Impervious Surface Area               | Click or tap here to enter text. <i>Square Feet</i> |



**STEP 2:** If applicable, include documentation in your submittal demonstrating that the following design strategies have been incorporated into your project (Check which strategies apply):

- Limit disturbance of creeks and natural drainage features
- Minimize compaction of highly permeable soils
- Limit clearing and grading of native vegetation at the site to the minimum area needed to build the project, allow access, and provide fire protection
- Minimize impervious surfaces by concentrating development on the least-sensitive portions of the site, while leaving the remaining land in a natural undisturbed state.

**STEP 3:** Select one or more Site Design Runoff Reduction Measure (at least one Option is required):

**Option 1: Soil Quality Improvement & Maintenance**

This is the simplest option. Amend project soils to increase permeability and promote creation of a microbial community.

Confirm the following standard specifications are met:

- Soils for landscaping meet the following bulk identities:
  - Sands, loamy sands: <1.6
  - Sandy loams, loams: <1.4
  - Sandy clay loams, loams, clay loams: <1.4
  - Silts, silt loams: <1.3
  - Silt loams, silty clay loams: <1.1
  - Sandy clays, silty clays, some clay loams (35-45% clay): <1.1
  - Clays (>45% clay): <1.1

**Option 2: Tree Planting & Preservation**

Plant and or preserve healthy established trees that include both evergreens and deciduous, as applicable. Install Environmental Sensitive Area (ESA) fencing to protect trees.



On the site plan, show:

- Location of each preserved tree/ new planted tree
- Species of each preserved tree/ new planted tree
- Diameter of each preserved tree
- ESA fencing locations
- Irrigation if applicable

**Option 3: Porous/Permeable Pavement**

Permeable pavements may include pervious concrete, pervious asphalt, porous pavers, crushed aggregate, open pavers with grass or plantings, open pavers with gravel, or solid pavers.

Permeable paving maybe substituted for conventional pavement on parking lots or other areas with light traffic.

Show on your site plan:

- Location, extent, and types of pervious pavements.

Confirm the following standard specifications are met:

- No erodible areas drain on to permeable pavement.
- Geotechnical investigation required to identify soil infiltration rate and to design the subgrade to support the anticipated traffic load. If known soil contamination is present, infiltration is not allowed.
- When infiltrating, 10 feet of separation between bottom of bed and seasonal high-water table.
- Subgrade compaction is minimal.
- Reservoir base course is of open-graded crushed stone. Base depth is adequate to retain rainfall (3 inches is adequate) and support design loads (more depth may be required).
- No subdrain is included or, if a subdrain is included, outlet elevation is a minimum of 3 inches above bottom of base course.



- Subgrade is uniform, and slopes are not so steep that subgrade is prone to erosion. Slopes of pervious pavement surface should not exceed 5% or up to 16% with underdrains. Slopes exceeding 3% typically require berms or check dams placed laterally over the soil subgrade to slow the flow of water and provide some infiltration.
- Rigid edge is provided to retain granular pavements and unit pavers.
- Solid unit pavers, if used, are set in sand or gravel with minimum 3/8-inch gaps between the pavers. Joints are filled with an open-graded aggregate free of fines.
- Permeable concrete or porous asphalt, if used, are installed by industry-certified professionals according to the vendor's recommendations.
- Selection and location of pavements incorporates *Americans with Disabilities Act* requirements (if applicable), site aesthetics, and uses.

#### Option 4: Self-Retaining Area- Rooftop & Impervious Area Disconnection

Downspouts can be directed to vegetated areas adjacent to buildings or extended via pipes to reach vegetated areas further away. Paved areas can be designed with curb cuts, or without curbs, to direct flow into surrounding vegetation.

On the site plan, show:

- Each impervious area from which runoff will be directed, and its square footage.
- The vegetated areas that will receive runoff, and the approximate square footage of each.
- If necessary, explain in notes on the plan how runoff will be routed from impervious surfaces to vegetated areas.

Confirm the following standard specifications are met:

- Tributary impervious square footage in no instance exceeds twice the square footage of the receiving pervious area.
- Roof areas collect runoff and route it to the receiving pervious area via gutters and downspouts.
- Paved areas are sloped so drainage is routed to the receiving pervious area.
- Runoff is dispersed across the vegetated area and energy dissipator is installed at downspout to avoid erosion and promote infiltration.
- Vegetated area has amended soils, vegetation, and irrigation if needed to maintain soil stability and permeability.





- Any drain inlets within the vegetated area allow for a maximum of 3 inches of ponding.
- Area of rooftop connecting to each downspout is 600 SF or less.
- The maximum contributing impervious flow path is less than 75 ft OR if  $\geq 75$  ft, then storage device is implemented to achieve required disconnection length.
- The impervious area to any one discharge location is less than 5,000 SF.
- Complete and Attach to this SWCP:
  - Self-Treating Area Calculations Worksheet** – found at the end of this Attachment.

**Option 5: Self-Retaining Area- Vegetated Swales**

This option includes vegetated shallow channels that collect and slowly convey runoff to downstream discharge points.

Show on your site plan:

- Location and impervious area that will drain into swale.

Confirm the following standard specifications are met:

- Vegetated side slopes at 2H:1V max slope. Mowed turf swales at 3H:1V max.
- Grass height 4"-6". Do not install trees if liner is present.
- Swale divider required for bottom widths  $> 10'$ . Min. required bottom width is 2' excluding width of low flow channel. Max. bottom width with divider is 16'.
- Depth of flow for water quality treatment must not exceed  $\frac{2}{3}$  of the grass height and not greater than 3" (infrequently mowed) or 2" (frequently mowed).
- Perforation pipe should have perforations set at 120 degrees and perforation slots should be pointed down.
- If no underdrain, low flow drain shall extend entire length of swale and shall have a depth of 6" minimum and width no more than 5% swale bottom width. If used, anchored plate flow spreader shall have v-notches (maximum top width 5% of swale width) or holes to allow preferential exit of low flows.
- Install check dams or grade control structures for slopes  $>6\%$  at 50" max spacing to achieve a max effective longitudinal slope of 6%. Flow spreaders must be provided at inlet and at base of each check dam.



- Install energy dissipator at the inlet.
- Swale length shall be 100' or length required to provide 10 minutes residence time, whichever is greater.
- Tributary impervious square footage in no instance exceeds twice the square footage of the receiving pervious area.
- Install appropriate outlet structure to accommodate low flow channel and/or underdrain, if present.
- Amend soils with 2" compost tilled into 6" of native soil unless native soil organic content is >10%.
- Maximum flow velocity for the runoff from the design storm event is less than or equal to 1.0 ft per second.
- 10-ft setback from foundations, 100-ft from septic fields and water supply wells, and 50-ft from steep slopes.
- BMP footprint is approximately 10-20% of the drainage area, drainage area less than 2 acres.

Complete and Attach to this SWCP:

- Self-Treating Area Calculations Worksheet** – found at the end of this Attachment.

#### **Option 6: Green Roofs**

Installing a vegetative layer on a roof can reduce the impervious coverage of the project.

Show on your site plan:

- Location and area of green roof that is impervious.
- Confirm the following standard specifications are met:
  - Roof slope less than 15% OR has grid to hold the substrate in place until it forms a thick vegetation mat.
  - PE has assessed the necessary load reserved and designed a roof structure to meet state and local needs.
  - Include irrigation plan, if necessary, to sustain the green roof during extended dry periods.
  - Incorporate watertight liner to prevent rainwater from intruding the underlying structure.



### Option 7: Rain Barrels & Cisterns

Use of cisterns or rain barrels to comply with this requirement is subject to municipality approval. Planning and Building Permits may be required from other agencies.

Show on your site plan:

- Impervious areas tributary to each cistern or rain barrel.
- Location of each cistern or rain barrel.

Confirm the following standard specifications are met:

- Rain barrels are sited at grade on a sound and level surface at or near gutter downspouts.
- Gutters tributary to rain barrels are screened with a leaf guard or maximum ½-inch to ¼-inch-minimum corrosion-resistant metallic hardware fabric.
- Water collected will be used for irrigation only.
- Openings are screened with a corrosion-resistant metallic fine mesh (1/16-inch or smaller) to prevent mosquito harborage.
- Large openings are secured to prevent entry by children.
- Rain barrels and gutters are to be cleaned annually.
- The local *mosquito and vector control* district is informed of the installation. The district will be provided additional information and/or rights of entry if they request.

### Option 8: Stream Setbacks & Buffers

A stream buffer is a vegetated area that exists or is established to protect a stream system, lake reservoir or coastal estuarine area.

Show on your site plan:

- Location of water body in proximity to project.
- Area of impervious area that will drain into a stream buffer.

Confirm the following standard specifications are met:

- Runoff from project enters flood prone width as sheet flow or within 500 ft of a stream channel as sheet flow (whichever is larger).



- Contributing overland slope is 5% or less OR if greater than 5% then a level spreader is used.
- The buffer area is protected from vehicle or other traffic barriers to reduce compaction.

Stream buffer will be maintained in an ungraded and uncompacted condition and vegetation will be maintained in a natural condition.

**STEP 4:** Prepare a Site Plan- which includes the following details on the plan:

- Locations of runoff reduction measures (indicate if the reduction measure was installed offsite)
- Show the impervious area—i.e. a roof, or portion of a roof, or a paved area—that will drain to your runoff reduction measure (typically these delineations follow roof ridge lines or grade breaks)
- Show the type and extent of pervious and impervious area both before and after construction.

**STEP 5:** Complete the Site Design Runoff Reduction Checklists and related calculations for each Runoff Reduction Measure selected in **Step 4**.

- Attach only the completed checklists for the Options(s) selected to this SWCP.
- Check to complete the **Self-Treating Area Calculations Worksheet** was selected as part of your option.
- Attach related CAD files for all drainage drawings with this SWCP.

**STEP 6:** To determine the Post-Construction Water Balance for the project, use the **State's Storm Water Multiple Application & Report Tracking System (SMARTS)** system or use the **Office of Water Programs (OWP) online California Phase II LID Sizing Tool- v1.1**. To use the SMARTS system, refer to Attachment G. To use the OWP Low Impact Development (LID) Sizing Tool refer to **Attachment H**.

- Take screenshots of the Water Balances and attach to this SWCP.

**STEP 7:** Designers must specify how to operate and maintain the BMPs selected by developing an **Operation and Maintenance (O&M) Manual**. The O&M Plan should include the Runoff Reduction Measures selected in the SWCP. Refer to **Attachment L** for a Template O&M Manual.

- Attach the completed O&M Manual to this SWCP.



**STEP 8:** If runoff reduction measures are not implemented for the required amount of runoff reduction, explain why such measures were not technically feasible and why stormwater treatment measures must be used.

- Explanation of why measures are not implemented for the required amount of runoff reduction:

**STEP 9:** Complete the **VTA Signoff for Stormwater and Landscaping Design, Attachment F** to this manual, and submit with this SWCP. Submittal of the Draft(s) and Final Stormwater Control Plans (SWCPs) should be concurrent with every major design submittal (i.e., 35%, 65%, 95%, and As-Built Record Documents after construction).

- Attach the VTA Signoff for Stormwater and Landscaping Design to this SWCP.



## Self-Retaining Area Calculations Worksheet

Self-retaining areas are pervious areas that retain rainfall on itself and runoff from an adjacent impervious area, up to a maximum 2:1 ratio (impervious: pervious). The entire self-retaining area must be designed to retain an inch of rainfall without flowing off-site. Drains, if any, should be set to allow a maximum of 3” of ponding.

Sizing calculations for self-retaining areas use a runoff coefficient to determine the amount of contributing runoff from different surfaces. Use the table below to determine the runoff coefficient for the impervious area contributing runoff to the self-retaining area. Then complete the calculations table below to determine the sizing criteria for each drainage management area using self-retaining areas to treat stormwater.

| Estimated Runoff Coefficient for Surfaces During Small Storms             |                        |
|---|------------------------|
| Type of Surface Contributing Run-Off                                      | Runoff Coefficient [A] |
| Roofs   | <u>.90</u>             |
| Concrete or Asphalt   |                        |
| Stone, Brick, or Concrete Pavers with mortared or sand joints and bedding |                        |
| Grass   | <u>.10</u>             |
| Permeable Pavement  |                        |
| Crushed Aggregate   |                        |

*Worksheet next page*





**ATTACHMENT D:**

**D2: SWCP TEMPLATE FOR  
REGULATED PROJECTS**





### Stormwater Control Plan for a Regulated Project

This template is to be used in conjunction with the instructions, criteria, and requirements in the Santa Clara Valley Transportation Authority's (VTA's) Stormwater and Landscaping Design Criteria Manual.

|  |  |
|--|--|
| Name of Project:                                   |  |
| Project Number                                     |  |
| Date:  |  |
| Name of Owner:                                     |  |
| Owner's Representative and Contact Information:    |  |
| Preparer's Name:                                   |  |
| Prepared by:                                       |  |
| Preparer's Contact Information:                    |  |
| Stamp of Licensed Professional Preparing the Plan: |  |



## Table of Contents

|  |    |
|--|----|
| 1. Instructions .....  | 1  |
| 2. Project Data .....  | 2  |
| 3. Setting.....  | 4  |
| A. Project Location and Description .....                              | 4  |
| B. Existing Site Features and Conditions.....                          | 4  |
| C. Opportunities and Constraints for Stormwater Control.....           | 4  |
| 4. Low Impact Development Design Strategies .....                      | 4  |
| A. Limit Disturbance.....  | 4  |
| B. Source Control BMPs .....   | 5  |
| C. Site Design Runoff Reduction Measures.....                          | 5  |
| D. Stormwater Treatment Measures and Sizing Criteria .....             | 6  |
| E. Post-Construction Water Balance .....                               | 7  |
| 5. Stormwater Control Plan Drawings Checklist.....                     | 7  |
| 6. Stormwater Operations and Maintenance Plan .....                    | 8  |
| Submittal and VTA Signoff .....  | 8  |
| Attachment 1: Source Control Checklist.....                            | 9  |
| Attachment 2: Stormwater Treatment Measure Checklists .....            | 23 |
| Attachment 3: Stormwater Treatment Measure Calculation Worksheets..... | 31 |



## ○ Instructions

This Stormwater Control Plan template is to be used as a guide for compliance with Section F.5.g.2 of the Phase II Small MS4 General Permit. As a Permittee, VTA is required to implement measures for design, source control, runoff reduction, stormwater treatment and baseline hydromodification for all development and re-development projects that create and/or replace 5,000 square feet or more of impervious surface (Regulated Projects). A registered Professional Engineer (P.E.) must complete this Stormwater Control Plan. **Complete the template below to submit a SWCP that includes the following:**

### Submittal Checklist:

- Project Data Form & Project Setting
- Design strategies to limit disturbance (if applicable)
- Completed Source Control Checklist
- Completed Site Design Runoff Reduction Checklists
- Explanation of Runoff Reduction Installation Infeasibility (if applicable)
- Completed Stormwater Treatment Measure Checklists
- Completed Stormwater Treatment Measure Calculation Worksheets
- Completed Stormwater Sizing Criteria Worksheets, if applicable (refer to SCVURPPP C.3 Handbook)
- SMARTS or OWP LID screenshots of completed Post-Construction Water Balance (or equivalent)
- Site Plan Drawings and supporting details and specifications
- O&M Plan for source controls, runoff reduction measures, and stormwater treatment measures
- Completed VTA Signoff for Stormwater and Landscaping Design



○ **Project Data Form**

| <b>Project Data Form</b>  |                    |
|---|--------------------|
| Project Name/Number   |                    |
| Application Submittal Date<br>[to be verified by VTA staff]   |                    |
| Date Design Initiated / Approval Date<br>[to be verified by VTA staff]  |                    |
| Construction Start Date   |                    |
| Construction End Date   |                    |
| Project Location<br>[Street Address, intersection and/or lat & long]  |                    |
| Project Phase No.<br><br>[If project is being constructed in phases, indicate the phase number. If not, enter "NA"] |                    |
| Name of Owner or Developer  |                    |
| Name of Project Manager   |                    |
| Project Type and Description<br>[Ex: "Parking Lot Addition," "Mixed use Transit Oriented Development"]              |                    |
| Total Site Area of Disturbed Land (acres)   | <u>Acres</u>       |
| Total Pre-Project Impervious Surface Area<br>(square feet)  | <u>Square Feet</u> |
| Total New or Replaced Impervious Surface Area<br>(square feet)  | <u>Square Feet</u> |
| Total Post-Project Impervious Surface Area<br>(square feet)   | <u>Square Feet</u> |



## ○ Setting

### A. Project Location and Description

Include site location, division of parcels, planned land uses, zoning, setback and open space requirements, project phasing, number of residential units or square footage of office or retail, parking requirements, neighborhood character, project design objectives (for example LEED certification), other notable project characteristics. A vicinity map may also be useful.

### B. Existing Site Features and Conditions

Include site size, shape, and topography. Hydrologic features, including any contiguous natural areas, wetlands, watercourses, seeps, or springs. Existing land uses. Soil types and hydrologic soil groups, vegetative cover, and impervious areas, if any. Existing drainage for site and nearby areas, including location of municipal storm drains.

### C. Opportunities and Constraints for Stormwater Control

Examples of opportunities: Existing natural areas, low areas, oddly configured or otherwise unbuildable areas, easements and required landscape amenities including open space and buffers that might be used for bioretention facilities, and differences in elevation, which can provide needed hydraulic head.

Examples of constraints: impermeable soils, high groundwater, groundwater pollution or contaminated soils, steep slopes, geotechnical instability, density/high-intensity land use, heavy pedestrian or vehicular traffic, utility locations, safety concerns.



## ○ Low Impact Development Design Strategies

### A. Limit Disturbance

If applicable, include documentation in your submittal demonstrating that the following design strategies have been incorporated into your project. **Check which strategies apply:**

- Limit disturbance of creeks and natural drainage features
- Minimize compaction of highly-permeable soils
- Limit clearing and grading of native vegetation at the site to the minimum area needed to build the project, allow access, and provide fire protection
- Minimize impervious surfaces by concentrating development on the least-sensitive portions of the site, while leaving the remaining land in a natural undisturbed state
- Not Applicable, if not applicable please explain why: [Click or tap here to enter text.](#)

### B. Source Control BMPs

Source control Best Management Practices (BMPs) are required as a first step for Regulated Projects. Source controls are designed to reduce the level of contaminants and their concentrations in stormwater runoff at the source rather than treating stormwater pollution. For new projects, designers shall assess the pollutants generated during operation of the facility and include BMPs as needed, which may include enclosures or structures to prevent contact of stormwater with pollutants. Complete the Source Control Checklist (**Attachment 1** of this document) to determine the appropriate Source Control BMPs.

Describe the site activities and related potential sources of pollutants as well as the BMPs selected to prohibit the discharge of such pollutants. Include all selected Permanent Source Controls on your SWCP Drawings.

### C. Site Design Runoff Reduction Measures

Site Design Runoff Reduction Measures must be incorporated into projects' design to reduce the amount of runoff to the extent technically feasible. **Select one or more Site Design Runoff Reduction Measure:**

#### Option 1: Soil Quality Improvement & Maintenance

This is the simplest option. Amend project soils to increase permeability and promote creation of a microbial community.

Confirm the following standard specifications are met:

- Soils for landscaping meet the following bulk identities:



- Sands, loamy sands: <1.6
- Sandy loams, loams: <1.4
- Sandy clay loams, loams, clay loams: <1.4
- Silts, silt loams: <1.3
- Silt loams, silty clay loams: <1.1
- Sandy clays, silty clays, some clay loams (35-45% clay): <1.1
- Clays (>45% clay): <1.1

**Option 2: Tree Planting & Preservation**

Plant and or preserve healthy established trees that include both evergreens and deciduous, as applicable. Install Environmental Sensitive Area (ESA) fencing to protect trees.

On the site plan, show:

- Location of each preserved tree/ new planted tree
- Species of each preserved tree/ new planted tree
- Diameter of each preserved tree
- ESA fencing locations
- Irrigation if applicable

**Option 3: Porous/Permeable Pavement**

Permeable pavements may include pervious concrete, pervious asphalt, porous pavers, crushed aggregate, open pavers with grass or plantings, open pavers with gravel, or solid pavers.

Permeable paving may be substituted for conventional pavement on parking lots or other areas with light traffic.

Show on your site plan:

- Location, extent, and types of pervious pavements.

Confirm the following standard specifications are met:

- No erodible areas drain on to permeable pavement.
- Geotechnical investigation required to identify soil infiltration rate and to design the subgrade to support the anticipated traffic load. If known soil contamination is present, infiltration is not allowed.
- When infiltrating, 10 feet of separation between bottom of bed and seasonal high-water table.



- Subgrade compaction is minimal.
- Reservoir base course is of open-graded crushed stone. Base depth is adequate to retain rainfall (3 inches is adequate) and support design loads (more depth may be required).
- No subdrain is included or, if a subdrain is included, outlet elevation is a minimum of 3 inches above bottom of base course.
- Subgrade is uniform, and slopes are not so steep that subgrade is prone to erosion. Slopes of pervious pavement surface should not exceed 5% or up to 16% with underdrains. Slopes exceeding 3% typically require berms or check dams placed laterally over the soil subgrade to slow the flow of water and provide some infiltration.
- Rigid edge is provided to retain granular pavements and unit pavers.
- Solid unit pavers, if used, are set in sand or gravel with minimum 3/8-inch gaps between the pavers. Joints are filled with an open-graded aggregate free of fines.
- Permeable concrete or porous asphalt, if used, are installed by industry-certified professionals according to the vendor's recommendations.
- Selection and location of pavements incorporates *Americans with Disabilities Act* requirements (if applicable), site aesthetics, and uses.

**Option 4: Self-Retaining Area- Rooftop & Impervious Area Disconnection**

Downspouts can be directed to vegetated areas adjacent to buildings or extended via pipes to reach vegetated areas further away. Paved areas can be designed with curb cuts, or without curbs, to direct flow into surrounding vegetation.

On the site plan, show:

- Each impervious area from which runoff will be directed, and its square footage.
- The vegetated areas that will receive runoff, and the approximate square footage of each.
- If necessary, explain in notes on the plan how runoff will be routed from impervious surfaces to vegetated areas.

Confirm the following standard specifications are met:

- Tributary impervious square footage in no instance exceeds twice the square footage of the receiving pervious area.
- Roof areas collect runoff and route it to the receiving pervious area via gutters and downspouts.
- Paved areas are sloped so drainage is routed to the receiving pervious area.
- Runoff is dispersed across the vegetated area and energy dissipator is installed at downspout to avoid erosion and promote infiltration.





- Vegetated area has amended soils, vegetation, and irrigation if needed to maintain soil stability and permeability.
- Any drain inlets within the vegetated area allow for a maximum of 3 inches of ponding.
- Area of rooftop connecting to each downspout is 600 SF or less.
- The maximum contributing impervious flow path is less than 75 ft OR if  $\geq 75$  ft, then storage device is implemented to achieve required disconnection length.
- The impervious area to any one discharge location is less than 5,000 SF.
- Complete and Attach to this SWCP:
- Self-Treating Area Calculations Worksheet** – found at the end of this Attachment.

**Option 5: Self-Retaining Area- Vegetated Swales**

This option includes vegetated shallow channels that collect and slowly convey runoff to downstream discharge points.

Show on your site plan:

- Location and impervious area that will drain into swale.

Confirm the following standard specifications are met:

- Vegetated side slopes at 2H:1V max slope. Mowed turf swales at 3H:1V max.
- Grass height 4"-6". Do not install trees if liner is present.
- Swale divider required for bottom widths > 10'. Min. required bottom width is 2' excluding width of low flow channel. Max. bottom width with divider is 16'.
- Depth of flow for water quality treatment must not exceed 2/3 of the grass height and not greater than 3" (infrequently mowed) or 2" (frequently mowed).
- Perforation pipe should have perforations set at 120 degrees and perforation slots should be pointed down.
- If no underdrain, low flow drain shall extend entire length of swale and shall have a depth of 6" minimum and width no more than 5% swale bottom width. If used, anchored plate flow spreader shall have v-notches (maximum top width 5% of swale width) or holes to allow preferential exit of low flows.
- Install check dams or grade control structures for slopes >6% at 50" max spacing to achieve a max effective longitudinal slope of 6%. Flow spreaders must be provided at inlet and at base of each check dam.
- Install energy dissipator at the inlet.
- Swale length shall be 100' or length required to provide 10 minutes residence time, whichever is greater.



- Tributary impervious square footage in no instance exceeds twice the square footage of the receiving pervious area.
- Install appropriate outlet structure to accommodate low flow channel and/or underdrain, if present.
- Amend soils with 2" compost tilled into 6" of native soil unless native soil organic content is >10%.
- Maximum flow velocity for the runoff from the design storm event is less than or equal to 1.0 ft per second.
- 10-ft setback from foundations, 100-ft from septic fields and water supply wells, and 50-ft from steep slopes.
- BMP footprint is approximately 10-20% of the drainage area, drainage area less than 2 acres.

Complete and Attach to this SWCP:

- Self-Treating Area Calculations Worksheet*** – found at the end of this Attachment.

#### **Option 6: Green Roofs**

Installing a vegetative layer on a roof can reduce the impervious coverage of the project.

Show on your site plan:

- Location and area of green roof that is impervious.
- Confirm the following standard specifications are met:
  - Roof slope less than 15% OR has grid to hold the substrate in place until it forms a thick vegetation mat.
  - PE has assessed the necessary load reserved and designed a roof structure to meet state and local needs.
  - Include irrigation plan, if necessary, to sustain the green roof during extended dry periods.
  - Incorporate watertight liner to prevent rainwater from intruding the underlying structure.

#### **Option 7: Rain Barrels & Cisterns**

Use of cisterns or rain barrels to comply with this requirement is subject to municipality approval. Planning and Building Permits may be required from other agencies.

Show on your site plan:

- Impervious areas tributary to each cistern or rain barrel.
- Location of each cistern or rain barrel.



Confirm the following standard specifications are met:

- Rain barrels are sited at grade on a sound and level surface at or near gutter downspouts.
- Gutters tributary to rain barrels are screened with a leaf guard or maximum ½-inch to ¼-inch-minimum corrosion-resistant metallic hardware fabric.
- Water collected will be used for irrigation only.
- Openings are screened with a corrosion-resistant metallic fine mesh (1/16-inch or smaller) to prevent mosquito harborage.
- Large openings are secured to prevent entry by children.
- Rain barrels and gutters are to be cleaned annually.
- The local *mosquito and vector control* district is informed of the installation. The district will be provided additional information and/or rights of entry if they request.

#### Option 8: Stream Setbacks & Buffers

A stream buffer is a vegetated area that exists or is established to protect a stream system, lake reservoir or coastal estuarine area.

Show on your site plan:

- Location of water body in proximity to project.
- Area of impervious area that will drain into a stream buffer.

Confirm the following standard specifications are met:

- Runoff from project enters flood prone width as sheet flow or within 500 ft of a stream channel as sheet flow (whichever is larger).
- Contributing overland slope is 5% or less OR if greater than 5% then a level spreader is used.
- The buffer area is protected from vehicle or other traffic barriers to reduce compaction.

Stream buffer will be maintained in an ungraded and uncompacted condition and vegetation will be maintained in a natural condition.

Complete the **Site Design Runoff Reduction Checklists** and related calculations (**Attachment E** of VTA's *Landscaping Design Criteria Manual*) for each Runoff Reduction Option selected.

- Attach only the completed checklists and calculations (if applicable) for the Options(s) selected to this SWCP.
- Attach related CAD files for all drainage drawings with this SWCP.



If runoff reduction measures are not implemented for the required amount of runoff reduction, explain why such measures were not technically feasible and why stormwater treatment measures must be used.

#### D. Stormwater Treatment Measures and Sizing Criteria

After incorporating Site Design Runoff Reduction Measures to the extent feasible, remaining runoff from impervious Drainage Management Areas (DMAs) must be directed to a bioretention facility, or equivalent. Bioretention facilities are designed to infiltrate, evapotranspire, and/or biotreat runoff based on the 85<sup>th</sup> percentile storm event.

Address each Drainage Management Area (DMA) requiring stormwater treatment and select a Stormwater Treatment Measure. A Bioretention Facility should be selected unless a permitted alternative design is met, special site conditions necessitate adjustments, or exceptions are needed due to infeasibility.

**Select one or more Stormwater Treatment Measures for the remaining runoff:**

##### **Option 1: Bioretention Facility**

Confirm the following standard specifications are met, if applicable, as required by the Phase II MS4 Permit, and include the relevant drawing details and specifications in your submittal:

Show on your site plan:

- Impervious areas tributary to the facility
- Location and footprint of the facility

Confirm the following standard specifications are met:

- Maximum surface loading rate of 5 inches per hour, based on the flow rates calculated. A sizing factor of 4% of tributary impervious area may be used.
- Minimum surface reservoir volume equal to surface area times a depth of 6 inches (6-inch ponding depth).
- Minimum planting medium depth of 18 inches. The planting medium must sustain a minimum infiltration rate of 5 inches per hour throughout the life of the project and must maximize runoff retention and pollutant removal.
- Subsurface drainage/storage (Class 2 gravel) layer with an area equal to the surface area and having a minimum depth of 12 inches.
- No compaction of soils beneath the facility or ripping/loosening of soils if compacted.
- No liners or other barriers interfering with infiltration (i.e. filter fabric). Design exceptions for impermeable liners are outlined in Option 2 below.



- Appropriate plant palette for the specified soil mix and maximum available water use. Refer to VTA's Sustainable Landscaping Policy.
- Overflow outlet connected to a downstream storm drain or approved discharge point. Overflow device has a 5mm perforated grate and allows for a min of 6" of ponding.
- Include irrigation system if needed. No overspray can enter the overflow. Consider use of a drip system.
- Perforation pipe should have perforations set at 120 degrees and perforation slot should be pointed down. At least 2" of drain rock should cover the underdrain. The underdrain should be placed at a minimum 0.5% slope to the storm drain or discharge point (unless a flatter slope is allowed based on site-specific conditions). It should be located with a discharge elevation at the top of gravel layer (typically) or at the bottom of the gravel layer (only if a design exception is needed for an impermeable liner).
- Energy dissipator: Install rock with filter fabric beneath it (or equivalent) at all openings to the basin. Rock should extend past opening.
- Slope must be no greater than 3:1.
- Indicate depth to groundwater.
- If basin has surrounding curb, the depth from the top of curve to the media should not exceed the height of the overflow by more than 2". If exceedance occurs consider safety measures, such as railing. Include curb cuts such that the flow of water is not impeded.

**NOTE:** basins that do not pond and/or allow any short circuiting to the underdrain due to excessively long/thin dimensions are not acceptable designs. Basin dimensions must allow for intended ponding. Designers may be required to demonstrate that ponding will occur using flow modeling.

***Special Site Conditions:***

**Option 2: Flow-Through Planter**

An above-ground planter box may be appropriate if the development site lacks level landscaped areas for dispersion and pervious pavements are not practical. Planter boxes can treat runoff from impervious surfaces and may adjust bioretention design parameters if certain special site conditions are met. Special site conditions and adjustments include:

- Facilities located within 10 feet of structures or other potential geotechnical hazards established by the geotechnical expert for the project:

Incorporate an impervious cutoff wall between the bioretention facility and the structure or other geotechnical hazard.



- Facilities in areas with documented high concentrations of pollutants in underlying soil or groundwater, facilities located where infiltration could contribute to a geotechnical hazard, and facilities located on elevated plazas or other structures:
  - Incorporate an impervious liner.
  - Include details indicating how impermeability will be achieved.
  - Locate the underdrain discharge at the bottom of the subsurface drainage/storage layer.
- Facilities located in areas of highly infiltrative soils or high groundwater, or where connection of underdrain to a surface drain or to a subsurface storm drain are infeasible:
  - Omit the underdrain.

Show on your site plan:

- Impervious areas tributary to the planter box.
- Location and footprint of planter box.

Confirm the following standard specifications are met:

- Maximum surface loading rate of 5 inches per hour, based on the flow rates calculated. A sizing factor of 4% of tributary impervious area may be used.
- Minimum surface reservoir volume equal to surface area times a depth of 6 inches (6-inch ponding depth).
- Minimum planting medium depth of 18 inches. The planting medium must sustain a minimum infiltration rate of 5 inches per hour throughout the life of the project and must maximize runoff retention and pollutant removal.
- Subsurface drainage/storage (Class 2 gravel) layer with an area equal to the surface area and having a minimum depth of 12 inches.
- No compaction of soils beneath the facility or ripping/loosening of soils if compacted.
- Appropriate plant palette for the specified soil mix and maximum available water use. Refer to VTA's Sustainable Landscaping Policy.
- Overflow outlet connected to a downstream storm drain or approved discharge point. Overflow device has a 5mm perforated grate and allows for a min of 6" of ponding.
- Planter is set level.
- Include irrigation system if needed. No overspray can enter the overflow. Consider use of a drip system.



- Perforation pipe should have perforations set at 120 degrees and perforation slot should be pointed down. At least 2" of drain rock should cover the underdrain. The underdrain should be placed at a minimum 0.5% slope to the storm drain or discharge point (unless a flatter slope is allowed based on site-specific conditions). It should be located with a discharge elevation at the top of gravel layer (typically) or at the bottom of the gravel layer (only if a design exception is needed for an impermeable liner).
- Energy dissipator: Install rock with filter fabric beneath it (or equivalent) at all openings to the planter. Rock should extend past opening.
- Slope must be no greater than 3:1.
- Indicate depth to groundwater.
- If planter has surrounding curb, the depth from the top of curve to the media should not exceed the height of the overflow by more than 2". If exceedance occurs consider safety measures, such as railing. Include curb cuts such that the flow of water is not impeded.

**NOTE:** Planters that do not pond and/or allow any short circuiting to the underdrain due to excessively long/thin dimensions are not acceptable designs. Basin dimensions must allow for intended ponding. Designers may be required to demonstrate that ponding will occur using flow modeling.

**Other:**

**Option 3: Alternative Design for Equivalent Bioretention Facility**

This option may be permitted if the following measures demonstrate equivalent effectiveness to a Bioretention Facility.

**Show on your site plan:**

- Impervious areas tributary to the planter box
- Location and footprint of the Alternative Design Bioretention Facility

**Confirm the following standard specifications are met:**

- An equal or greater amount of runoff is infiltrated or evapotranspired
- An equal or lower pollutant concentration in runoff that is discharged after bioretention
- An equal or greater protection against shock loadings and spills



- An equal or greater accessibility and ease of inspection and maintenance
- Overflow fitted with 5 mm perforated grate

**Option 4: Tree-Box-Type Biofilter/ Tree-Well Filter**

A Tree-Box-Type Biofilter or Tree-Well Filter may be used if it is demonstrated that the use of a bioretention facility (Option 1) or facility of equivalent effectiveness (Option 3) is infeasible. These may be used for the following:

- Projects creating or replacing an acre or less of impervious area, and located in a designated pedestrian-oriented commercial district (i.e., Smart Growth projects), and having at least 85% of the entire project site covered by permanent structures
- Facilities receiving runoff solely from existing (pre-project) impervious areas
- Historic sites, structures, or landscapes that cannot alter their original configuration to maintain their historic integrity

**Show on your site plan:**

- Impervious areas tributary to the tree filter
- Location and footprint of tree filter

**Confirm the following standard specifications are met:**

- Overflow fitted with 5 mm perforated grate.
- Impervious area slopes to top of tree filter.
- Vegetation is centered in treatment area.
- Perforation pipe should have perforations set at 120 degrees and perforation slots should be pointed down or installed per manufacturer's recommendation.
- Ensure that the drip line of trees does not impede pedestrians.
- Install mulch, per manufacturer's recommendation.
- Include irrigation system if needed. No overspray can enter the overflow. Consider use of a drip system.
- The top of the impervious surface to the top of the planting media layer should be a maximum depth of 1 foot or per the manufacturer's recommendation.





- Inflow rate is that generated by a continuous rainfall intensity of 0.2 inches/hour.

*Maximum design surface loading rate of 50 inches per hour.*

- Inlet design to capture flows at least up to the maximum design surface loading rate and to bypass high flows.
- Minimum media depth of 3.5 feet (may be reduced, but maintaining the same media volume, if required because of inadequate head to discharge point).

#### **Option 5: In-Vault Media Filter**

An In-Vault Media Filter may be used if it is demonstrated that the use of a bioretention facility (Option 1) or facility of equivalent effectiveness (Option 3) is infeasible. These may be used for the following:

- Projects creating or replacing an acre or less of impervious area, and located in a designated pedestrian-oriented commercial district (i.e., smart growth projects), and having at least 85% of the entire project site covered by permanent structures
- Facilities receiving runoff solely from existing (pre-project) impervious areas
- Historic sites, structures, or landscapes that cannot alter their original configuration to maintain their historic integrity.

#### **Show on your site plan:**

- Impervious areas tributary to the media filter
- Location and footprint of the media filter

#### **Confirm the following standard specifications are met:**

- Overflow fitted with 5 mm perforated grate
- Impervious area slopes to media filter
- Inflow rate is that generated by a continuous rainfall intensity of 0.2 inches per hour
- Replaceable cartridge filters
- Maximum design filter surface loading rate of 1 gpm/ft<sup>2</sup>
- Storage volume detains runoff and allows settling of coarse solids prior to filtration
- Flow through the cartridge filters is controlled by an orifice or other device so that the design surface loading rate is not exceeded



**Other biotreatment or media filter**

Other(description):

Describe the overall site comparison of pre-construction surfaces to post-construction surfaces. Describe each DMA and identify the Site Design Runoff Reduction Measures and Stormwater Treatment Measures installed to reduce/treat stormwater runoff.

Complete the **Stormwater Treatment Measure Calculation Worksheets (Attachment 2** of this document) for each Stormwater Treatment Measure selected above.

- Attach only the completed checklists and related calculations for the Options(s) selected to this SWCP.
- Attach related CAD files for all drainage drawings with this SWCP.

Alternatively, use of an “equivalent” method to quantify stormwater treatment is acceptable. Designers may also size the stormwater treatment measures using volumetric or flow-based hydraulic sizing criteria. If this method is used, refer to the **Santa Clara Valley Urban Runoff Pollution Prevention Program (SC-VURPPP) C.3 Stormwater Handbook** and complete the Sizing Criteria Worksheets.

- Attach the completed worksheets to this SWCP. In addition, provide the *applicable* details for the calculations in the Volumetric & Flow-Based Criteria Table in **Attachment 2** of this document.

#### E. Post-Construction Water Balance

To determine the post-construction water balance for the project, use the State’s Storm Water Multiple Application & Report Tracking System (SMARTS) system or use the Office of Water Programs (OWP) on-line California Phase II LID Sizing Tool- v1.1.

To use the SMARTS system, refer to **Attachment G** of the *VTA Stormwater and Landscaping Design Criteria Manual*. Take screenshots of the Water Balance and attach to this SWCP. To use the OWP Low Impact Development (LID) Sizing Tool refer to **Attachment H** of the *VTA Stormwater and Landscaping Design Criteria Manual*.

- Take screenshots of the Water Balance and attach to this SWCP.



○ **Stormwater Control Plan Drawings Checklist**

Verify incorporation of SWCP requirements in drawings/plan sheets:

| Stormwater Control Plan Page # | Source Control or Treatment Control Measure | See Plan Sheet #s |
|--------------------------------|---|-------------------|
|                                |   |                   |
|                                |   |                   |
|                                |   |                   |

○ **Stormwater Operations and Maintenance Plan**

Designers must specify how to operate and maintain the BMPs selected by developing an **Operation and Maintenance (O&M) Manual**. The O&M Plan should include the Source Controls, Runoff Reduction Measures, and Stormwater Treatment Measures selected in the SWCP. Refer to **Attachment L** of the *VTA Stormwater and Landscaping Design Criteria Manual* for a Template O&M Manual.

- Attach the completed O&M Manual to this SWCP.

○ **Submittal and VTA Signoff**

Complete the **VTA Signoff for Stormwater and Landscaping Design, Attachment F** of the *VTA Stormwater and Landscaping Design Criteria Manual* and submit with this SWCP. Submittal of the Draft(s) and Final Stormwater Control Plans (SWCPs) should be concurrent with every major design submittal (i.e., 35%, 65%, 95% and As-Built Record Documents after construction).



## Attachment 1: Source Control Checklist

### Instructions:

1. Review Column 1 and identify which of these potential sources of stormwater pollutants apply to your site. Check each box that applies.
2. Review Column 2 and incorporate all corresponding applicable Structural/Permanent Source Control BMPs in your Stormwater Control Plan drawings.
3. Review Columns 3 and 4 and incorporate all corresponding applicable Structural Source Control BMPs and Operational Source Control BMPs in a table in your Stormwater Control Plan. Describe your specific BMPs in your SWCP and explain any special conditions or situations that required omitting BMPs or substituting alternative BMPs.

| If these sources will be used on the project site...   | ...Then your Stormwater Control Plan (SWCP) should include these Source Control BMP's |   |   |
|--|---|---|---|
| 1<br>Potential Sources of Runoff Pollutants  | 2<br>Permanent Source Controls—Show on SWCP Drawings                                  | 3<br>Permanent Source Controls—Include in this SWCP Table   | 4<br>Operational Source Control BMPs—Include in this SWCP Table   |
| <input type="checkbox"/> A. On-site storm drain inlets (unauthorized non-stormwater discharges and accidental spills or leaks) | <input type="checkbox"/> Location of inlets.  | <input type="checkbox"/> Mark all inlets with VTA's medallion stating "No Dumping. Flows to Bay" or similar.  | <input type="checkbox"/> Maintain and periodically replace inlet medallions.<br><input type="checkbox"/> Provide stormwater pollution prevention information and the "Stormwater Awareness for VTA Tenants" training tri-fold to new site owners, lessees, or operators.<br><input type="checkbox"/> See applicable operational BMPs in Fact Sheet SC-44, "Drainage System Maintenance," in the CASQA Stormwater Quality Handbooks at <a href="http://www.casqa.org/resources/bmp-handbooks">www.casqa.org/resources/bmp-handbooks</a><br><input type="checkbox"/> Include VTA's MS4 Lease Conditions in all lease agreements |
| <input type="checkbox"/> B. Escalators, elevators, and sump pumps  | <input type="checkbox"/> Show drains and pump locations                               | <input type="checkbox"/> State that sump pumps will be plumbed to a sand oil interceptor or to sanitary sewer.<br><br><input type="checkbox"/> Designer coordinated directly with Engineering and Program Delivery Department and Deputy Director of Rail and Facilities or their designee, and alternate design coupled with VTA O&M is equivalent to this BMP. Attach signoff for MS4 approval. | <input type="checkbox"/> Inspect and maintain drains to prevent blockages and overflow.   |

| If these sources will be used on the project site...                                   | ...Then your Stormwater Control Plan (SWCP) should include these Source Control BMP's  |   |  |
|--|--|---|--|
| 1<br>Potential Sources of Runoff Pollutants  | 2<br>Permanent Source Controls—Show on SWCP Drawings   | 3<br>Permanent Source Controls—Include in this SWCP Table   | 4<br>Operational Source Control BMPs—Include in this SWCP Table  |
| <input type="checkbox"/> C. Interior parking garages                                   | <input type="checkbox"/> Show drain locations  | <input type="checkbox"/> State that parking garage floor drains will be plumbed to the sanitary sewer. This provides a means to drain fire sprinkler test water and other non-stormwater discharges to the sanitary sewer.  | <input type="checkbox"/> Inspect and maintain drains to prevent blockages and overflow.  |
| <input type="checkbox"/> D1. Need for future indoor, outdoor & structural pest control |  | <input type="checkbox"/> Note building design features that discourage entry of pests OR stormwater design features that may impede mosquito abatement (such as trash capture devices).<br><br><input type="checkbox"/> Design landscaping to minimize the use of fertilizers and pesticides that can contribute to stormwater pollution.<br><br><input type="checkbox"/> Consider using pest-resistant plants, especially adjacent to hardscape.   | <input type="checkbox"/> Provide Integrated Pest Management (IPM) information to owners, lessees, and operators.<br><br><input type="checkbox"/> Maintain landscaping using minimum or no pesticides.<br><br><input type="checkbox"/> See applicable operational BMPs in Fact Sheet SC-41, "Building and Grounds Maintenance," in the CASQA Stormwater Quality Handbooks at <a href="http://www.casqa.org/resources/bmp-handbooks">www.casqa.org/resources/bmp-handbooks</a> |
| <input type="checkbox"/> D2. Landscape and Grounds Maintenance/ Irrigation             | <input type="checkbox"/> Show locations of native trees or areas of shrubs and ground cover to be undisturbed and retained.<br><br><input type="checkbox"/> Show self-retaining landscape areas, if any.<br><br><input type="checkbox"/> Show bioretention facilities. | <input type="checkbox"/> State that final landscape plans will accomplish all of the following.<br><br><input type="checkbox"/> Preserve existing native trees, shrubs, and ground cover to the maximum extent possible.<br><br><input type="checkbox"/> Where landscaped areas are used to retain or detain stormwater, specify plants that are tolerant of saturated soil conditions.<br><br><input type="checkbox"/> Limit use of irrigation. If irrigation is used, limit run-off.<br><br><input type="checkbox"/> To ensure successful establishment, select plants appropriate to site soils, slopes, climate, sun, wind, rain, land use, air movement, ecological consistency, and plant interactions. Refer to VTA's Landscaping Policy.<br><br><input type="checkbox"/> Provide a means to drain fire department test water to landscaping where feasible. | <input type="checkbox"/> Provide Integrated Pest Management (IPM) information to owners, lessees, and operators.<br><br><input type="checkbox"/> See applicable operational BMPs in Fact Sheet SC-41, "Building and Grounds Maintenance," in the CASQA Stormwater Quality Handbooks at <a href="http://www.casqa.org/resources/bmp-handbooks">www.casqa.org/resources/bmp-handbooks</a>  |
| <input type="checkbox"/> E. Ponds, decorative fountains, and other water features.     | <input type="checkbox"/> Show location of water feature and a sanitary sewer cleanout in an accessible area within 10 feet.  |   | <input type="checkbox"/> See applicable operational BMPs in Fact Sheet SC-72, "Fountain and Pool Maintenance," in the CASQA Stormwater Quality Handbooks at <a href="http://www.casqa.org/resources/bmp-handbooks">www.casqa.org/resources/bmp-handbooks</a>   |

| If these sources will be used on the project site... | ...Then your Stormwater Control Plan (SWCP) should include these Source Control BMP's   |  |   |
|--|---|--|---|
| 1<br>Potential Sources of Runoff Pollutants          | 2<br>Permanent Source Controls—Show on SWCP Drawings  | 3<br>Permanent Source Controls—Include in this SWCP Table  | 4<br>Operational Source Control BMPs—Include in this SWCP Table   |
| <input type="checkbox"/> F. Food service             | <input type="checkbox"/> For restaurants and other food service operations, show location (indoors or in a covered area outdoors) of a floor sink or other area for cleaning floor mats, containers, and equipment.<br><br><input type="checkbox"/> On the drawing, show a note that this drain will be connected to a grease interceptor before discharging to the sanitary sewer. | <input type="checkbox"/> Describe the location and features of the designated cleaning area.<br><br><input type="checkbox"/> Describe the items to be cleaned in this facility and how it has been sized to ensure that the largest items can be accommodated. | <input type="checkbox"/> State maintenance schedule for grease interceptor  |
| <input type="checkbox"/> G. Refuse areas             | <input type="checkbox"/> Show where site refuse and recycled materials will be handled and stored for pickup. See local municipal requirements for sizes and other details of refuse areas.<br><br><input type="checkbox"/> Any drains from dumpsters, compactors, and tallow bin areas shall be connected to a grease removal device before discharge to sanitary sewer.           | <input type="checkbox"/> State how site refuse will be handled and provide supporting detail to what is shown on plans.  | <input type="checkbox"/> State how the following will be implemented:<br><br><input type="checkbox"/> Provide adequate number of receptacles. Inspect receptacles regularly; repair or replace leaky receptacles. Ensure all receptacles have lids. Ensure O&M crew picks up litter as needed.  |
| <input type="checkbox"/> H. Industrial processes.    | <input type="checkbox"/> Show process area.   | <input type="checkbox"/> If industrial processes are to be located on site, state: "All process activities to be performed indoors. No processes to drain to exterior or to storm drain system."   | <input type="checkbox"/> Clean up spills immediately. Keep spill control materials available on-site.<br><br><input type="checkbox"/> See Fact Sheet SC-34, "Waste Handling and Disposal" and Fact Sheet SC-10, "Non-Stormwater Discharges" in the CASQA Stormwater Quality Handbooks at <a href="http://www.casqa.org/resources/bmp-handbooks">www.casqa.org/resources/bmp-handbooks</a> |

| If these sources will be used on the project site...  | ...Then your Stormwater Control Plan (SWCP) should include these Source Control BMP's  |   |   |
|---|--|---|---|
| 1<br>Potential Sources of Runoff Pollutants   | 2<br>Permanent Source Controls—Show on SWCP Drawings   | 3<br>Permanent Source Controls—Include in this SWCP Table   | 4<br>Operational Source Control BMPs—Include in this SWCP Table   |
| <p><input type="checkbox"/> I. Outdoor storage of equipment or materials. (See rows J and K for source control measures for vehicle cleaning, repair, and maintenance.)</p> | <p><input type="checkbox"/> Show any outdoor storage areas, including how materials will be covered. Show how areas will be graded and bermed to prevent run-on or run-off from area.</p> <p><input type="checkbox"/> Storage of non-hazardous liquids shall be covered and in secondary containment and/or drain to the sanitary sewer system, and be contained by berms, dikes, liners, or vaults.</p> <p><input type="checkbox"/> Storage of hazardous materials and wastes must be in compliance with the local hazardous materials ordinance and a Hazardous Materials Management Plan for the site.</p>  | <p><input type="checkbox"/> Include a detailed description of materials to be stored, storage areas, and structural features to prevent pollutants from entering storm drains.</p> <p><input type="checkbox"/> Where appropriate, reference documentation of compliance with the requirements of programs for: Hazardous Waste Generation, Hazardous Materials Release Response and Inventory, California Accidental Release (CalARP), Aboveground Storage Tank, Uniform Fire Code Article 80 Section 103(b) &amp; (c) 1991, and Underground Storage Tank</p> | <p><input type="checkbox"/> See the Fact Sheets SC-31, “Outdoor Liquid Container Storage” and SC-33, “Outdoor Storage of Raw Materials” in the CASQA Stormwater Quality Handbooks at <a href="http://www.casqa.org/resources/bmp-handbooks">www.casqa.org/resources/bmp-handbooks</a></p>   |
| <p><input type="checkbox"/> J. Vehicle and Equipment Cleaning</p>   | <p><input type="checkbox"/> Show on drawings as appropriate:</p> <p><input type="checkbox"/> (1) Commercial/industrial facilities having vehicle/equipment cleaning needs shall either provide a covered, bermed area for washing activities or discourage vehicle/equipment washing by removing hose bibs and installing signs prohibiting such uses.</p> <p><input type="checkbox"/> (2) Washing areas for cars, vehicles, and equipment shall be paved, designed to prevent run-on to or runoff from the area, and plumbed to drain to the sanitary sewer.</p> <p><input type="checkbox"/> (3) Industrial car wash facilities shall be designed such that no runoff from the facility is discharged to the storm drain system. Wastewater from the facility shall discharge to the sanitary sewer, or a wastewater reclamation system shall be installed.</p> | <p><input type="checkbox"/> If a car wash area is not provided, describe measures taken to discourage on-site car washing and explain how these will be enforced.</p>   | <p><input type="checkbox"/> Describe operational measures to implement the following (if applicable):</p> <p><input type="checkbox"/> Wash water from vehicle and equipment washing operations shall not be discharged to the storm drain system.</p> <p><input type="checkbox"/> See Fact Sheet SC-21, “Vehicle and Equipment Cleaning,” in the CASQA Stormwater Quality Handbooks at <a href="http://www.casqa.org/resources/bmp-handbooks">www.casqa.org/resources/bmp-handbooks</a></p> |



| If these sources will be used on the project site...                 | ...Then your Stormwater Control Plan (SWCP) should include these Source Control BMP's   |   |   |
|--|---|---|---|
| 1<br>Potential Sources of Runoff Pollutants                          | 2<br>Permanent Source Controls—Show on SWCP Drawings  | 3<br>Permanent Source Controls—Include in this SWCP Table   | 4<br>Operational Source Control BMPs—Include in this SWCP Table   |
| <input type="checkbox"/> K. Vehicle/Equipment Repair and Maintenance | <input type="checkbox"/> Accommodate all vehicle equipment repair and maintenance indoors. Or designate an outdoor work area and design the area to prevent run-on and runoff of stormwater.<br><br><input type="checkbox"/> Show secondary containment for exterior work areas where motor oil, brake fluid, gasoline, diesel fuel, radiator fluid, acid-containing batteries or other hazardous materials or hazardous wastes are used or stored. Drains shall not be installed within the secondary containment areas.<br><br><input type="checkbox"/> Add a note on the plans that states either (1) there are no floor drains, or (2) floor drains are connected to wastewater pretreatment systems prior to discharge to the sanitary sewer and an industrial waste discharge permit will be obtained, if needed. | <input type="checkbox"/> State that no vehicle repair or maintenance will be done outdoors, or else describe the required features of the outdoor work area.<br><br><input type="checkbox"/> State that there are no floor drains or if there are floor drains, note the agency from which an industrial waste discharge permit will be obtained and that the design meets that agency's requirements.<br><br><input type="checkbox"/> State that there are no tanks, containers or sinks to be used for parts cleaning or rinsing or, if there are, note the agency from which an industrial waste discharge permit will be obtained and that the design meets that agency's requirements. | <input type="checkbox"/> In the Stormwater Control Plan, note that all the following restrictions apply to use the site:<br><br><input type="checkbox"/> No person shall dispose of, nor permit the disposal, directly or indirectly of vehicle fluids, hazardous materials, or rinse water from parts cleaning into storm drains.<br><br><input type="checkbox"/> No vehicle fluid removal shall be performed outside a building, nor on asphalt or ground surfaces, whether inside or outside a building, except in such a manner as to ensure that any spilled fluid will be in an area of secondary containment. Leaking vehicle fluids shall be contained or drained from the vehicle immediately.<br><br><input type="checkbox"/> No person shall leave unattended parts or other open containers containing vehicle fluid, unless such containers are in use or in an area of secondary containment. |
| <input type="checkbox"/> L. Fuel Dispensing Areas                    | <input type="checkbox"/> Fueling areas shall have impermeable floors (i.e., portland cement concrete or equivalent smooth impervious surface) that are: a) graded at the minimum slope necessary to prevent ponding; and b) separated from the rest of the site by a grade break that prevents run-on of stormwater to the maximum extent practicable.<br><br><input type="checkbox"/> Fueling areas shall be covered by a canopy that extends a minimum of ten feet in each direction from each pump. [Alternative: The fueling area must be covered and the cover's minimum dimensions must be equal to or greater than the area within the grade break or fuel dispensing area1.] The canopy [or cover] shall not drain onto the fueling area.   |   | <input type="checkbox"/> The property owner shall dry sweep the fueling area routinely.<br><br><input type="checkbox"/> See the Business Guide Sheet, "Automotive Service—Service Stations" in the CASQA Stormwater Quality Handbooks at <a href="http://www.casqa.org/resources/bmp-handbooks">www.casqa.org/resources/bmp-handbooks</a>   |

| If these sources will be used on the project site...  | ...Then your Stormwater Control Plan (SWCP) should include these Source Control BMP's   |   |  |
|---|---|---|--|
| 1<br>Potential Sources of Runoff Pollutants   | 2<br>Permanent Source Controls—Show on SWCP Drawings  | 3<br>Permanent Source Controls—Include in this SWCP Table   | 4<br>Operational Source Control BMPs—Include in this SWCP Table  |
| <input type="checkbox"/> M. Loading Docks   | <input type="checkbox"/> Show the loading dock area, including roofing and drainage. Loading docks shall be covered and/or graded to minimize run-on to and runoff from the loading area. Roof downspouts shall be positioned to direct stormwater away from the loading area. Water from loading dock areas shall be drained to the sanitary sewer or diverted into treatment.<br><br><input type="checkbox"/> Loading dock areas draining directly to the sanitary sewer shall be equipped with a spill control valve or equivalent device, which shall be kept closed during periods of operation.<br><br><input type="checkbox"/> Provide a roof overhang over the loading area |   | <input type="checkbox"/> Move loaded and unloaded items indoors as soon as possible.<br><br><input type="checkbox"/> See Fact Sheet SC-30, "Outdoor Loading and Unloading," in the CASQA Stormwater Quality Handbooks at <a href="http://www.casqa.org/resources/bmp-handbooks">www.casqa.org/resources/bmp-handbooks</a>  |
| <input type="checkbox"/> N. Miscellaneous Drain or Wash Water or Other Sources<br><br><input type="checkbox"/> Boiler drain lines<br><input type="checkbox"/> Condensate drain lines<br><input type="checkbox"/> Rooftop equipment<br><input type="checkbox"/> Drainage sumps<br><input type="checkbox"/> Roofing, gutters, and trim.<br><input type="checkbox"/> Other sources | <input type="checkbox"/> Show drain lines and drainage sumps  | <input type="checkbox"/> Boiler drain lines shall be directly or indirectly connected to the sanitary sewer system and may not discharge to the storm drain system.<br><br><input type="checkbox"/> Condensate drain lines may discharge to landscaped areas if the flow is small enough that runoff will not occur. Condensate drain lines may not discharge to the storm drain system.<br><br><input type="checkbox"/> Rooftop equipment with potential to produce pollutants shall be roofed and/or have secondary containment.<br><br><input type="checkbox"/> Include controls for other sources as specified by local reviewer. | <input type="checkbox"/> If architectural copper is used, implement the following BMPs for management of rinse water during installation:<br><br><input type="checkbox"/> If possible, purchase copper materials that have been pre-patinated at the factory.<br><br><input type="checkbox"/> If patination is done on-site, prevent rinse water from entering storm drains by discharging to landscaping or by collecting in a tank and hauling off-site.<br><br><input type="checkbox"/> Consider coating the copper materials with an impervious coating that prevents further corrosion and runoff.<br><br><input type="checkbox"/> Implement the following BMPs during routine maintenance:<br><br><input type="checkbox"/> Prevent rinse water from entering storm drains by discharging to landscaping or by collecting in a tank and hauling off-site. |



| If these sources will be used on the project site...             | ...Then your Stormwater Control Plan (SWCP) should include these Source Control BMP's |   |   |
|--|---|---|---|
| 1<br>Potential Sources of Runoff Pollutants                      | 2<br>Permanent Source Controls—Show on SWCP Drawings                                  | 3<br>Permanent Source Controls—Include in this SWCP Table | 4<br>Operational Source Control BMPs—Include in this SWCP Table   |
| <input type="checkbox"/> O. Plazas, sidewalks, and parking lots. | <input type="checkbox"/> Show extent of permeable paving materials                    |   | <input type="checkbox"/> Sweep plazas, sidewalks, and parking lots regularly to prevent accumulation of litter and debris. Collect debris from pressure washing to prevent entry into the storm drain system. Collect wash water containing any cleaning agent or degreaser and discharge to the sanitary sewer not to a storm drain. |

## Attachment 2: Stormwater Treatment Measure Calculation Worksheets

Site design will be dependent on the area of the proposed post-construction impervious surfaces in comparison to the pre-construction impervious surfaces. Fill out the tables below to guide your treatment measure sizing requirements.

### Total Pervious and Impervious Surfaces Comparison

| Project Title | Total Area (SF) | Pre-Construction     |                    | Post-Construction    |                    | Pre-Con to Post-Con   |  |  |
|---------------|-----------------|----------------------|--------------------|----------------------|--------------------|-----------------------|--|--|
|               |                 | Impervious Area (SF) | Pervious Area (SF) | Impervious Area (SF) | Pervious Area (SF) | Impervious Area       |  |  |
|               |                 | [A]                  |                    | [B]                  |                    | SF: $[B] - [A] = [C]$ | % increase or decrease: $[C/A] \times 100$ | % Increase   |
|               |                 |                      |                    |                      |                    |                       |  | <input type="checkbox"/> >50%<br><input type="checkbox"/> <50% |

### Total Pervious and Impervious Surfaces Comparison- Roadway Projects

Fill out the table below for public road projects and/or any projects that are under the building and planning authority of a Permittee.

| Project Title | Total Area (SF) | Pre-Construction     |                    | Post-Construction    |                    | Pre-Con to Post-Con |   |
|---------------|-----------------|----------------------|--------------------|----------------------|--------------------|---------------------|---|
|               |                 | Impervious Area (SF) | Pervious Area (SF) | Impervious Area (SF) | Pervious Area (SF) | Impervious Area     |   |
|               |                 | [A]                  |                    | [B]                  |                    | SF: $[B-A] = [C]$   | Is [C] greater than or equal to 5,000 SF?                   |
|               |                 |                      |                    |                      |                    |                     | <input type="checkbox"/> Yes<br><input type="checkbox"/> No |

### Drainage Management Areas with Stormwater Treatment Measures

Bioretention facilities are designed to infiltrate, evapotranspire, and/or biotreat runoff based on the 85th percentile 24-hour storm event. Fill out the tables below for each Drainage Management Area (DMA) requiring stormwater treatment.

A sizing factor of a minimum of 4% of the tributary impervious area may be used. If this method is used, complete the sizing calculations for the 4% method below.

Designers may also size the bioretention basin using volumetric or flow-based hydraulic sizing criteria. If this method is used, refer to the Santa Clara Valley Urban Runoff Pollution Prevention Program (SCVURPPP) C.3 Stormwater Handbook and complete the Sizing Criteria Worksheets. Attach the completed worksheets to this SWCP. In addition, provide the *applicable* details for the calculations in the Volumetric & Flow-Based Criteria Table below.



Sizing calculations for bioretention facilities use a runoff coefficient to determine the amount of contributing runoff from different surfaces. Use the Table below to determine the runoff coefficient for the impervious area contributing runoff to the facility. Then Complete the calculations table below to determine the sizing criteria for each drainage management area using bioretention facilities to treat stormwater.

| Estimated Runoff Coefficient for Surfaces During Small Storms             |                        |
|---|------------------------|
| Type of Surface Contributing Run-Off                                      | Runoff Coefficient [A] |
| Roofs   | .90                    |
| Concrete or Asphalt   |                        |
| Stone, brick, or concrete pavers with mortared or sand joints and bedding |                        |
| Grass   | .10                    |
| Permeable Pavement  |                        |
| Crushed aggregate   |                        |



Bioretention Facility Sizing Calculations – 4% Method

| DMA ID (as referred to on drawings) | Total Drainage Management Area (SF) | Post Project Impervious Surface Type | Runoff Coefficient<br>[A] | Impervious Surface Area (SF)<br>[B] | Contributing Runoff (SF)<br>[C] = [A] x [B] | Receiving Pervious Bioretention Area (SF)<br>[D] | Impervious Ratio<br>[E] = [D] / [C] | Meets minimum sizing factor of 4%?<br>([E] ≥ 0.04)          |
|-------------------------------------|-------------------------------------|--------------------------------------|---------------------------|-------------------------------------|---|--|-------------------------------------|---|
|                                     |                                     |                                      |                           |                                     |   |  |                                     | <input type="checkbox"/> Yes<br><input type="checkbox"/> No |
|                                     |                                     |                                      |                           |                                     |   |  |                                     | <input type="checkbox"/> Yes<br><input type="checkbox"/> No |

Bioretention Facility Sizing Calculations – Volumetric & Flow-Based Criteria

| DMA ID | Soil Type | Receiving Pervious Area (SF) | Impervious Surface Area (SF) | Post Project Impervious Surface Type | Runoff Coeff. | Depth to Groundwater (ft., in.) | Design Treatment Intensity<br>(i=x in/hr) | Design Rainfall Intensity<br>(l=x in/hr) | Treatment Flow Rate (CFS) | Unit Basin Storage (in.) | Basin Design Volume (CF) | Duration of Design Storm (hr.) |
|--------|-----------|------------------------------|------------------------------|--------------------------------------|---------------|---------------------------------|---|--|---------------------------|--------------------------|--------------------------|--------------------------------|
|        |           |                              |                              |                                      |               |                                 |   |  |                           |                          |                          |                                |
|        |           |                              |                              |                                      |               |                                 |   |  |                           |                          |                          |                                |



**ATTACHMENT E:**  
SITE DESIGN RUNOFF REDUCTION CHECKLISTS



## Site Design Runoff Reduction Measure Checklists

### Instructions:

Complete the Checklists for each Site Design Runoff Reduction Measure selected for incorporation in your site design. Attach only the completed checklists to this Stormwater Control Plan (SWCP).

### Option 1: Soil Quality Improvement & Maintenance

This is the simplest option. Amend project soils to increase permeability and promote creation of a microbial community.

Confirm the following standard specifications are met:

- Soils for landscaping meet the following bulk identities:
  - Sands, loamy sands: <1.6
  - Sandy loams, loams: <1.4
  - Sandy clay loams, loams, clay loams: <1.4
  - Silts, silt loams: <1.3
  - Silt loams, silty clay loams: <1.1
  - Sandy clays, silty clays, some clay loams (35-45% clay): <1.1
  - Clays (>45% clay): <1.1





## Site Design Runoff Reduction Measure Checklists

### Option 2: Tree Planting & Preservation

Plant and or preserve healthy established trees that include both evergreens and deciduous, as applicable. Install Environmental Sensitive Area (ESA) fencing to protect trees.

On the site plan, show:

- Location of each preserved tree/ new planted tree
- Species of each preserved tree/ new planted tree
- Diameter of each preserved tree
- ESA fencing locations
- Irrigation if applicable



### Option 3: Porous/Permeable Pavement

Permeable pavements may include pervious concrete, pervious asphalt, porous pavers, crushed aggregate, open pavers with grass or plantings, open pavers with gravel, or solid pavers. Permeable paving may be substituted for conventional pavement on parking lots or other areas with light traffic.

Show on your site plan:

- Location, extent, and types of pervious pavements.

Confirm the following standard specifications are met:

- No erodible areas drain on to permeable pavement.
- Geotechnical investigation required to identify soil infiltration rate and to design the subgrade to support the anticipated traffic load. If known soil contamination is present, infiltration is not allowed.
- When infiltrating, 10 feet of separation between bottom of bed and seasonal high water table.
- Subgrade compaction is minimal.
- Reservoir base course is of open-graded crushed stone. Base depth is adequate to retain rainfall (3 inches is adequate) and support design loads (more depth may be required).
- No subdrain is included or, if a subdrain is included, outlet elevation is a minimum of 3 inches above bottom of base course.
- Subgrade is uniform, and slopes are not so steep that subgrade is prone to erosion. Slopes of pervious pavement surface should not exceed 5% or up to 16% with underdrains. Slopes exceeding 3% typically require berms or check dams placed laterally over the soil subgrade to slow the flow of water and provide some infiltration.
- Rigid edge is provided to retain granular pavements and unit pavers.
- Solid unit pavers, if used, are set in sand or gravel with minimum 3/8-inch gaps between the pavers. Joints are filled with an open-graded aggregate free of fines.
- Permeable concrete or porous asphalt, if used, are installed by industry-certified professionals according to the vendor's recommendations.
- Selection and location of pavements incorporates *Americans with Disabilities Act* requirements (if applicable), site aesthetics, and uses.



## Site Design Runoff Reduction Measure Checklists

### Option 4: Self-Retaining Area- Rooftop & Impervious Area Disconnection

Downspouts can be directed to vegetated areas adjacent to buildings or extended via pipes to reach vegetated areas further away. Paved areas can be designed with curb cuts, or without curbs, to direct flow into surrounding vegetation.

On the site plan, show:

- Each impervious area from which runoff will be directed, and its square footage.
- The vegetated areas that will receive runoff, and the approximate square footage of each.
- If necessary, explain in notes on the plan how runoff will be routed from impervious surfaces to vegetated areas.

Confirm the following standard specifications are met:

- Tributary impervious square footage in no instance exceeds twice the square footage of the receiving pervious area.
- Roof areas collect runoff and route it to the receiving pervious area via gutters and downspouts.
- Paved areas are sloped so drainage is routed to the receiving pervious area.
- Runoff is dispersed across the vegetated area and energy dissipator is installed at downspout to avoid erosion and promote infiltration.
- Vegetated area has amended soils, vegetation, and irrigation if needed to maintain soil stability and permeability.
- Any drain inlets within the vegetated area allow for a maximum of 3 inches of ponding.
- Area of rooftop connecting to each downspout is 600 SF or less.
- The maximum contributing impervious flow path is less than 75 ft OR if  $\geq 75$  ft, then storage device is implemented to achieve required disconnection length.
- The impervious area to any one discharge location is less than 5,000 SF.
- Complete and Attach to this SWCP:
- Self-Treating Area Calculations Worksheet*** – found at the end of this Attachment.



### Option 5: Self-Retaining Area- Vegetated Swale

This option includes vegetated shallow channels that collect and slowly convey runoff to downstream discharge points.

Show on your site plan:

- Location and impervious area that will drain into swale.

Confirm the following standard specifications are met:

- Vegetated side slopes at 2H:1V max slope. Mowed turf swales at 3H:1V max.
- Grass height 4"-6". Do not install trees if liner is present.
- Swale divider required for bottom widths > 10'. Min. required bottom width is 2' excluding width of low flow channel. Max. bottom width with divider is 16'.
- Depth of flow for water quality treatment must not exceed 2/3 of the grass height and not greater than 3" (infrequently mowed) or 2" (frequently mowed).
- Perforation pipe should have perforations set at 120 degrees and perforation slots should be pointed down.
- If no underdrain, low flow drain shall extend entire length of swale and shall have a depth of 6" minimum and width no more than 5% swale bottom width. If used, anchored plate flow spreader shall have v-notches (maximum top width 5% of swale width) or holes to allow preferential exit of low flows.
- Install check dams or grade control structures for slopes >6% at 50" max spacing to achieve a max effective longitudinal slope of 6%. Flow spreaders must be provided at inlet and at base of each check dam.
- Install energy dissipator at the inlet.
- Swale length shall be 100' or length required to provide 10 minutes residence time, whichever is greater.
- Tributary impervious square footage in no instance exceeds twice the square footage of the receiving pervious area.
- Install appropriate outlet structure to accommodate low flow channel and/or underdrain, if present.
- Amend soils with 2" compost tilled into 6" of native soil unless native soil organic content is >10%.
- Maximum flow velocity for the runoff from the design storm event is less than or equal to 1.0 ft per second.
- 10-ft setback from foundations, 100-ft from septic fields and water supply wells, and 50-ft from steep slopes.
- BMP footprint is approximately 10-20% of the drainage area, drainage area less than 2 acres.

Complete and Attach to this SWCP:

- Self-Treating Area Calculations Worksheet** – found at the end of this Attachment.



## Site Design Runoff Reduction Measure Checklists

### Option 6: Green Roof

Installing a vegetative layer on a roof can reduce the impervious coverage of the project.

Show on your site plan:

- Location and area of green roof that is impervious.
- Confirm the following standard specifications are met:
  - Roof slope less than 15% OR has grid to hold the substrate in place until it forms a thick vegetation mat.
  - PE has assessed the necessary load reserved and designed a roof structure to meet state and local needs.
  - Include irrigation plan, if necessary to sustain the green roof during extended dry periods.
  - Incorporate watertight liner to prevent rainwater from intruding the underlying structure.



## Site Design Runoff Reduction Measure Checklists

### Option 7: Rain Barrels and Cisterns

Use of cisterns or rain barrels to comply with this requirement is subject to municipality approval. Planning and Building Permits may be required from other agencies.

Show on your site plan:

- Impervious areas tributary to each cistern or rain barrel.
- Location of each cistern or rain barrel.

Confirm the following standard specifications are met:

- Rain barrels are sited at grade on a sound and level surface at or near gutter downspouts.
- Gutters tributary to rain barrels are screened with a leaf guard or maximum ½-inch to ¾-inch-minimum corrosion-resistant metallic hardware fabric.
- Water collected will be used for irrigation only.
- Openings are screened with a corrosion-resistant metallic fine mesh (1/16-inch or smaller) to prevent mosquito harborage.
- Large openings are secured to prevent entry by children.
- Rain barrels and gutters are to be cleaned annually.
- The local *mosquito and vector control* district is informed of the installation. The district will be provided additional information and/or rights of entry if they request.



## Site Design Runoff Reduction Measure Checklists

### Option 8: Stream Setbacks and Buffers

A stream buffer is a vegetated area that exists or is established to protect a stream system, lake reservoir or coastal estuarine area.

Show on your site plan:

- Location of water body in proximity to project.
- Area of impervious area that will drain into a stream buffer.

Confirm the following standard specifications are met:

- Runoff from project enters flood prone width as sheet flow or within 500 ft of a stream channel as sheet flow (whichever is larger).
- Contributing overland slope is 5% or less OR if greater than 5% then a level spreader is used.
- The buffer area is protected from vehicle or other traffic barriers to reduce compaction.

Stream buffer will be maintained in an ungraded and uncompacted condition and vegetation will be maintained in a natural condition.



## Site Design Runoff Reduction Measure Checklists

### Self-Retaining Area Calculations Worksheet

Self-retaining areas are pervious areas that retain rainfall on itself and runoff from an adjacent impervious area, up to a maximum 2:1 ratio (impervious: pervious). The entire self-retaining area must be designed to retain an inch of rainfall without flowing off-site. Drains, if any, should be set to allow a maximum of 3" of ponding.

Sizing calculations for self-retaining areas use a runoff coefficient to determine the amount of contributing runoff from different surfaces. Use the table below to determine the runoff coefficient for the impervious area contributing runoff to the self-retaining area. Then complete the calculations table below to determine the sizing criteria for each drainage management area using self-retaining areas to treat stormwater.

| Estimated Runoff Coefficient for Surfaces During Small Storms             |                        |
|---|------------------------|
| Type of Surface Contributing Run-Off                                      | Runoff Coefficient [A] |
| Roofs   | .90                    |
| Concrete or Asphalt   |                        |
| Stone, Brick, or Concrete Pavers with mortared or sand joints and bedding |                        |
| Grass   | .10                    |
| Permeable Pavement  |                        |
| Crushed Aggregate   |                        |

*Worksheet next page*





## Site Design Runoff Reduction Measure Checklists

### Self-Retaining Area Calculations Worksheet

| Project Title/<br>Number/<br>& Design<br>Unit | DMA ID (as<br>referred to on<br>drawings) | Total Drainage<br>Management<br>Area (SF) | Post<br>Project<br>Imperv.<br>Surface<br>Type | Runoff<br>Coefficient<br>[A] | Impervious<br>Surface Area<br>(SF) [B] | Contributing<br>Runoff<br>(SF) [C] = [A] x<br>[B] | Receiving<br>Pervious Self-<br>Retaining<br>Area (SF) [D] | Ratio<br>[C]: [D] | Meets<br>requirement of<br>max. 2:1,<br>impervious to<br>pervious? |
|---|---|---|---|------------------------------|--|---|---|-------------------|--|
|   |   |   |   |                              |  |   |   |                   | <input type="checkbox"/> Yes<br><input type="checkbox"/> No        |
|   |   |   |   |                              |  |   |   |                   | <input type="checkbox"/> Yes<br><input type="checkbox"/> No        |
|   |   |   |   |                              |  |   |   |                   | <input type="checkbox"/> Yes<br><input type="checkbox"/> No        |
|   |   |   |   |                              |  |   |   |                   | <input type="checkbox"/> Yes<br><input type="checkbox"/> No        |
|   |   |   |   |                              |  |   |   |                   | <input type="checkbox"/> Yes<br><input type="checkbox"/> No        |
|   |   |   |   |                              |  |   |   |                   | <input type="checkbox"/> Yes<br><input type="checkbox"/> No        |



**ATTACHMENT F:**

VTA SIGNOFF FOR STORMWATER AND  
LANDSCAPING DESIGN



## VTA Signoff for Stormwater and Landscaping Design

### Name of Project:

-----

1) Phase of Design:  35%,  65%,  95%,  As-Built Record Documents, or

Other: -----

2) Type of Right-of-Way (Select all that apply):

- VTA
- City
- County
- Caltrans
- Transit Oriented Joint Development (TOJD)
- Multi-Jurisdictional – check all that apply above

3) Reviewer Name:

VTA-CGP During-Construction Stormwater: Route to Remi Awosanya, VTA Construction Contract Compliance Officer

VTA-MS4 Post-Construction Stormwater: Route to Alex Nelson, MS4 Program Manager

4) During Construction Stormwater Best Management Practices (BMPs):

- Project disturbs **less than 1 acre (Refer to Template Tech Specs for ESCAPE)**:
  - Attach site plan and Temporary Water Pollution Control Drawings.
  - Attach (Permanent) Erosion Control drawings and/or integrate erosion control in Landscaping Drawings.
  - Include pay item for preparing the ESCAPE in Bid Form and Engineer's Estimate.
  - Include **unit** pay items for all measurable BMPs **installed** in Bid Form and Engineer's Estimate.
  - Include pay items for **maintaining** BMPs, by measurable **unit item** (i.e., by cubic yard of rock placed in a TC-1 Entrance/Exit) in Bid Form and Engineer's Estimate.
  - Include pay items for inspection and reporting to VTA (refer to **Appendix G** of VTA's contract specifications).
- Project disturbs **more than 1 acre (Refer to Template Tech Specs for SWPPP)**:
  - Complete and attach a preliminary calculation of project Risk Level (based on location and soil types).
  - Attach Temporary Water Pollution Control Drawings.
  - Attach (Permanent) Erosion Control drawings and/or integrate erosion control in Landscaping Drawings.



## VTA Signoff for Stormwater and Landscaping Design

Solutions that move you

- Include pay item for preparing the SWPPP in Bid Form and Engineer's Estimate.
- Include **unit** pay items for all measurable BMPs **installed** in Bid Form and Engineer's Estimate.
- Include pay items for **maintaining** BMPs, by measurable **unit item** (i.e., by cubic yard of rock placed in a TC-1 Entrance/Exit) in Bid Form and Engineer's Estimate.
- Include pay items for inspection and reporting in SMARTS (refer to **Appendix G** of VTA's contract specifications).
- Include pay items for filing the Notice of Termination in SMARTS.

### 5) Post-Construction Stormwater BMPs:

*Note: when calculating the applicable impervious area of a road project, include all roadway surfaces related to creation of additional traffic lanes (including, for example, passing lanes and turning pockets). Shoulders and widened portion of **existing** lanes may be excluded from the calculation.*

#### 5a) Check reason **if exempt** from Post-Construction Stormwater Requirements:

**\*NOTE: if Caltrans project, skip to #5 (below)**

- i.  Governing body/designee approved initiation of the project design prior to June 30, 2015.  
The date for "initiation of design" for VTA projects is when the SAP budget charges against a design contract that advances the project forward. (*Attach schedule and budget showing design expenditures prior to 6/30/15, as proof of design initiation.*)
- ii.  Less than 2,500 square feet impervious area are to be constructed or replaced.
- iii.  Project consists of interior remodel or routine maintenance or repair such as roof or exterior surface replacement, pavement resurfacing, and repaving within the existing footprint.
- iv.  Project is a Roads or Linear Underground and Overhead Project (LUP) and less than 5,000 square feet of contiguous impervious area are to be constructed or replaced, once the following are excluded from the tally of impervious area:
  - Sidewalks and bicycle lanes built as part of new streets or roads and built to direct stormwater runoff to adjacent vegetated areas.
  - Impervious trails built to direct stormwater runoff to adjacent vegetated areas or other non- erodible permeable areas, preferably away from creeks or towards the outboard side of levees.
  - Sidewalks, bicycle lanes, or trails constructed with permeable surfaces (pervious concrete, porous asphalt, unit pavers, or granular materials).
  - Trenching, excavation, and resurfacing associated with LUPs; pavement grinding and resurfacing of existing roadways and parking lots; construction of new sidewalks, pedestrian ramps, or bike lanes on



## VTA Signoff for Stormwater and Landscaping Design

existing roadways; and routine replacement of damaged pavement such as pothole repair or replacement of short, non-contiguous sections of roadway.

- v.  Caltrans project is:
  - A Highway Facility project that creates <1 acre of new impervious surface.
  - A Non-Highway Facility project that creates <5,000 square feet of new impervious surface.

### 5b) If not exempt from Post-Construction Requirements, check stormwater permit(s) that apply:

- VTA - MS4 Section F
- City - MRP Section C.3
- County - MRP Section C.3
- Caltrans NPDES
- Transit Oriented Joint Development (TOJD) - MRP Section C.3
- Multi-Jurisdictional - check all that apply above

### 5c) Post-Construction Requirements: Compliance documentation (35%, 65%, and 95% Design)

The following documents show that the project meets all Phase II MS4 Permit Section F requirements, as outlined in the VTA Storm Water and Landscaping Design Criteria Manual:

*\*NOTE: if Caltrans project, skip to #4 (below)*

- i. If project is not a roads project and 2,500 square feet or more of impervious area, and less than 5,000 square feet, is to be constructed or replaced:
  - Attach Stormwater Control Plan and drawings with calculations. Use the template "Stormwater Control Plan and Checklist for Small Projects" from the Design Criteria Manual.  
**Date of plan:** Click or tap to enter a date.
  - Attach approved plant list.
  - Attach CADD-Manual compliant drainage and grading plans (native electronic file link/flash drive as well as .pdf copies).
- ii. If project is not a roads project and 5,000 or more square feet of impervious area is to be constructed or replaced:
  - Attach the Stormwater Control Plan and drawings with calculations. Use the template "Stormwater Control Plan and Checklist for Regulated



**VTA Signoff for Stormwater and Landscaping Design**

*Solutions that move you*

Projects” from the Design Criteria Manual. **Date of plan:** Click or tap to enter a date.

- Attach approved plant list.
- Attach CADD-Manual compliant drainage and grading plans (native electronic file link/flash drive as well as .pdf copies).
- iii. If project is a Roadway/LUP project with 5,000 square feet or more of impervious area:
  - Attach drawings/calculations documenting incorporation of USEPA’s *Managing Wet Weather with Green Infrastructure Municipal Handbook Green Streets* guidelines. **Date of drawings:** Click or tap to enter a date.
  - Attach approved plant list.
  - Attach CADD-Manual compliant drainage and grading plans (native electronic file link/flash drive as well as .pdf copies).
- iv. If Caltrans project is a Highway Facility project that creates 1 acre or more of new impervious surface OR if Caltrans project is a Non-Highway Facility project that creates 5,000 square feet or more of new impervious surface:
  - Attach a Stormwater Data Report

**FOR ALL PROJECTS:**

- Attach **drawings** showing how all areas will achieve **temporary and final construction site stabilization** (during and after construction). Provide native electronic file link/flash drive as well as .pdf and Word copies.

65%, 95%, and Ready for Bid Reviews only, add the following:

- Attach all relevant water pollution control treatment features, drainage, and grading **specifications.**

95% and Ready for Bid Reviews only, add the following:

- Attach all relevant water pollution control treatment features, drainage and grading **estimate and bid items to be included in the estimate.**

Following construction:

- VTA PM to forward As-Build drawings to Compliance Officer and MS4 Program Manager.

**After signing, please scan and email with Attachments**



VTA Signoff for Stormwater and Landscaping Design

---

**Prior to Construction Received/ Approved:**

VTA Project Manager Signature & Date:

-----

VTA Construction Contract Compliance Office Signature & Date:

-----

VTA MS4 Program Manager & Date:

-----

**VTA STAFF: Complete and send all documentation to the VTA Construction Contract Compliance Officer for CGP and the MS4 Program Manager for MS4. Ensure that VTA GIS and Survey receive copies of all CADD files for drainage.**

---

**AFTER Construction: As-Built Record Drawings Received/ Approved:**

VTA Project Manager Signature & Date:

-----

VTA Construction Contract Compliance Office Signature & Date:

-----

VTA MS4 Program Manager & Date:

-----

**VTA STAFF: Complete and send all documentation to the VTA Construction Contract Compliance Officer for CGP and the MS4 Program Manager for MS4. Ensure that VTA GIS and Survey receive copies of all CADD files for drainage.**





**ATTACHMENT G:**  
SMARTS USER GUIDE





## SMARTS User Guide

### Part 1: Submitting Project Information in SMARTS

Use the State's Storm Water Multiple Application & Report Tracking System (SMARTS) system to determine the preliminary Risk Level for a Traditional construction project or to determine the post-construction water balance for the project.

**Step 1:** If you do not have access to SMARTS use the guide for getting a SMARTS account at the following link:

[https://smarts.waterboards.ca.gov/smarts/faces/help/new\\_user\\_registration.pdf](https://smarts.waterboards.ca.gov/smarts/faces/help/new_user_registration.pdf)

**Step 2:** Login to your SMARTS account. ↻



**Step 3:** Navigate to Construction General Permit. ↻





## SMARTS User Guide

Step 4: Navigate to New NOI/Waiver Application. 



Water Boards Storm Water Multiple Application & Report Tracking System

You are logged-in as: \_\_\_\_\_  
if this account does not belong to you, please log out.

Welcome to Storm Water Multiple Application Reporting and Tracking System - SMARTS

**Construction Permit Menu**

- New NOI/Waiver Application** (circled in red)
- Active NOIs
- Pending NOIs/NOIs/COs
- Terminated NOIs
- Annual/Ad hoc Reports
- CBPEL SG - QSD
- Back to Main Menu

| Application ID | Application Type   | Status        |
|----------------|--------------------|---------------|
| 31000          | Construction - NOI | Not Submitted |
|                | Construction - NOI | Not Submitted |
|                | Construction - NOI | Not Submitted |

Step 5: Navigate to Construction Storm Water General Permit. 

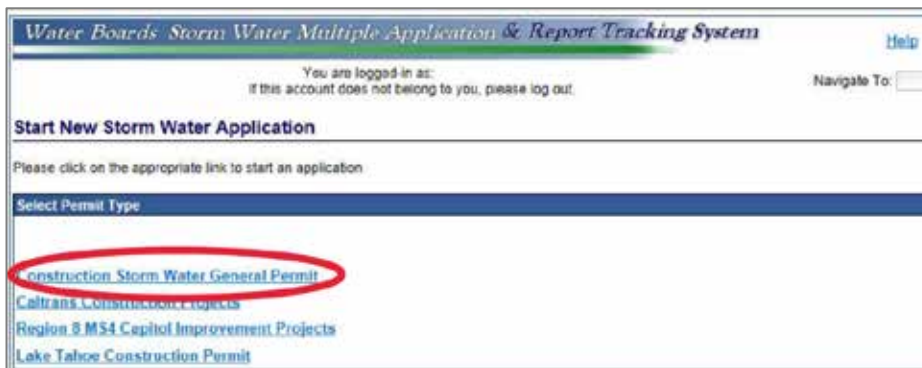

Water Boards Storm Water Multiple Application & Report Tracking System

You are logged-in as: \_\_\_\_\_  
if this account does not belong to you, please log out.

**Start New Storm Water Application**

Please click on the appropriate link to start an application

**Select Permit Type**

- Construction Storm Water General Permit** (circled in red)
- Caltrans Construction Projects
- Region 8 MS4 Capitol Improvement Projects
- Lake Tahoe Construction Permit

Step 6: Select the Owner/Operator. 

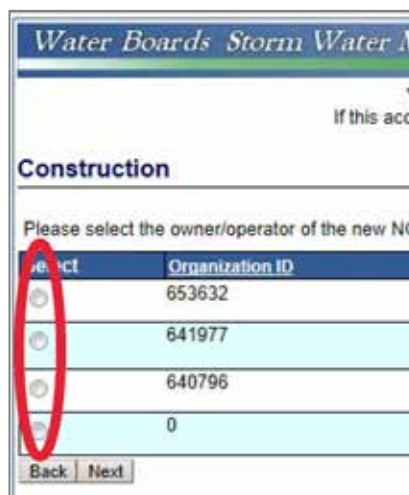

Water Boards Storm Water Multiple Application & Report Tracking System

You are logged-in as: \_\_\_\_\_  
if this account does not belong to you, please log out.

**Construction**

Please select the owner/operator of the new NOI

| Project                          | Organization ID |
|----------------------------------|-----------------|
| <input checked="" type="radio"/> | 653632          |
| <input type="radio"/>            | 641977          |
| <input type="radio"/>            | 640796          |
| <input type="radio"/>            | 0               |

Back Next



## SMARTS User Guide

**Step 7:** Go to the Site Info tab and enter the project information.

**Step 8:** Take a Screen Shot and Save for submittal.

**Step 9:** Click the Save & Continue button. ↻

*Water Boards Storm Water Multiple Application & Report Tracking System* [Help](#)

You are logged-in as: \_\_\_\_\_  
If this account does not belong to you, please log out. Navigate To: \_\_\_\_\_

### Site Information

The application is organized into different tabs. Please complete all applicable tabs before submitting the form. If you want to complete the application at a later time, please click on "Save & Exit".

WDID/App ID: - 503804 Owner: \_\_\_\_\_  
Status: Not Submitted Site: \_\_\_\_\_  
Order No: 2009-0009-DWQ  
Permit Type: Construction - NOI

**Owner Info** **Developer Info** **Site Info** **Risk** **Add. Site Info** **Post Construction** **Billing Info** **Attachments** **Certification** **Reports** **Inspections** **Print** **Status History** **Linked Users** **NOTs** **COs**

Site Information | Same as Owner Info | Same as Developer Info | Clear Info | If different, enter below

|  |                           |
|--|---------------------------|
| Site Name: _____ *   | Contact First Name: _____ |
| Street Address: _____ *  | Contact Last Name: _____  |
| Address Line 2: _____  | Title: _____              |
| Latitude: _____ * Longitude: _____ * <a href="#">Lookup Map</a><br>(Decimal degrees only, minimum 5 significant digits Ex: 99.99999) | Phone: _____ *            |
| City: AA _____ *   | Emergency Phone: _____ E  |
| County: Select _____ *   | E-mail: _____             |
| Regional Board: Select _____ *   | Total Site Size: _____ *  |
| State/Zip: CA _____ *  |                           |

### Additional Information (Construction Specific)

|  |  |
|--|--|
| Total Area to be Disturbed: _____ Acres *  | Percent of Total Disturbed: _____        |
| Imperviousness Before Construction: _____ % *  | Imperviousness After Construction: _____ |
| Tract Number(s): _____   |  |
| Mile Post Marker: _____  |  |
| Is the construction site part of larger common plan of development? <input type="radio"/> Yes <input type="radio"/> No * |  |
| Name of plan or development: _____   |  |
| Construction Commencement Date: _____ (mm/dd/yyyy)   |  |
| Complete Grading Date: _____ (mm/dd/yyyy)  | Complete Project Date: _____             |

### Type of Construction

Construction

Residential  Commercial  Industrial  Reconstruction  Transportation  Utility: \_\_\_\_\_

Other: \_\_\_\_\_ \*

Linear Utility Project

Above Ground  Below Ground  Gas Line  Water/Sewer Line  Communication Line  Cable Line  Electrical

Other: \_\_\_\_\_ \*



## SMARTS User Guide

### Part 2: Preliminary Risk Level Calculation

To determine the preliminary Risk Level for a Traditional construction project, use the State's Storm Water Multiple Application & Report Tracking System (SMARTS) system.

**Steps 1 – 9:** Complete Steps 1-9 in Part 1.

**Step 10:** Navigate to the Risk tab.

**Step 11:** Click on the Erosivity Calculator in the Sediment Risk Factor Worksheet. 



| Owner Info   | Developer Info | Site Info | Risk | Apply | Site Info | Post Construction | Billing Info | Attachments | Certification | Reports | Inspections | Print | Status History | Linked Users | NOTs | COs |
|--|----------------|-----------|------|-------|-----------|-------------------|--------------|-------------|---------------|---------|-------------|-------|----------------|--------------|------|-----|
| <b>SEDIMENT RISK FACTOR WORKSHEET</b><br>Instructions: Enter R,K and LS factor values. System will calculate watershed erosion estimates and site sediment risk factor |                |           |      |       |           |                   |              |             |               |         |             |       |                |              |      |     |
| A) Sediment Risk   |                |           |      |       |           |                   |              |             |               |         |             |       |                |              |      |     |
| A) R Factor Value: <input type="text"/>  |                |           |      |       |           |                   |              |             |               |         |             |       |                |              |      |     |
| B) K Factor Value (weighted average, by area, for all site soils) <input type="text"/>   |                |           |      |       |           |                   |              |             |               |         |             |       |                |              |      |     |
| C) LS Factor (weighted average, by area, for all slopes) <input type="text"/>  |                |           |      |       |           |                   |              |             |               |         |             |       |                |              |      |     |
| <b>Watershed Erosion Estimate (=R*K*LS) in tons/acre</b>   |                |           |      |       |           |                   |              |             |               |         |             |       |                |              |      |     |
| <b>Site Sediment Risk Factor</b>   |                |           |      |       |           |                   |              |             |               |         |             |       |                |              |      |     |
| Low Sediment Risk: <= 15 tons/acre   |                |           |      |       |           |                   |              |             |               |         |             |       |                |              |      |     |
| Medium Sediment Risk: >= 15 and <75 tons/acre  |                |           |      |       |           |                   |              |             |               |         |             |       |                |              |      |     |
| High Sediment Risk: >= 75 tons/acre  |                |           |      |       |           |                   |              |             |               |         |             |       |                |              |      |     |



## SMARTS User Guide

Step 12: Fill in the requested information and press submit. ↻

**Select a construction period**

**Start Date:**

(Format: mm/dd/yyyy)

**End Date:**

(Format: mm/dd/yyyy)

The start date is the date of initial earth disturbance. The end date is the date of final site stabilization.

**NOTE: If your construction project extends beyond the estimated end date, you will need to either recalculate the R factor based on a new end date, or apply for NPDES permit coverage.**

**Please enter the Latitude/Longitude information of the project/site.**

**(Do not enter negative numbers)**

**Latitude**  °  '  " N  
(Degrees/Minutes/Seconds)

**Longitude:**  °  '  " W  
(Degrees/Minutes/Seconds)

**Latitude**  °  .  ' N  
(Degrees/Minutes.Decimal Minutes)

**Longitude:**  °  .  ' W  
(Degrees/Minutes.Decimal Minutes)

**Latitude**  .  ° N  
(Decimals)

**Longitude:**  .  ° W  
(Decimals)

**If you do NOT have the Latitude/Longitude information, please enter the project/site address.**

**Address:**



## SMARTS User Guide

**Step 13:** Navigate back to the SMARTS **Sediment Risk Factor Worksheet** and fill in the **R** factor with the calculated erosivity index value.

**Step 14:** Populate the **K Factor** and the **LS Factor**. ↻

**Step 15:** Read the three questions outlined in the **Receiving Water (RW) Risk Factor Worksheet** and Select **Yes** if the answer is yes to any of the three questions. Select **No** if the answer is no to all three questions.

**Step 16:** Select **Populate Receiving Water Risk**. ↻



## SMARTS User Guide

\*Note that the **Combined Risk Level Matrix** automatically populates from the **Sediment and Receiving Water Risk Factor Worksheets**.

**Step 17:** Take a Screen Shot and save for submittal. Press **Save & Continue**. 

C. Combined Risk Level Matrix

|                      |      | Sediment Risk |        |        |
|----------------------|------|---------------|--------|--------|
|                      |      | Low           | Medium | High   |
| Receiving Water Risk | Low  | Level1        | Level2 |        |
|                      | High | Level2        |        | Level3 |

Project Sediment Risk:

Project Receiving Water Risk:

Project Combined Risk:

---

Save & Exit



## SMARTS User Guide

### Part 3: Post-Construction Water Balance:

To determine the post-construction water balance for the project, use the State's **Storm Water Multiple Application & Report Tracking System (SMARTS)** system.

**Steps 1 – 9:** Complete Steps 1-9 in **Part 1**.

**Step 10:** Go to the **Post Construction** tab and answer the questions. Questions will appear in SMARTS as questions are answered. Below are a few possible outcomes.

#### Option 1:

Owner Info Developer Info Site Info Risk Addl. Site Info **Post Construction** Planning Info Attachments Certification Requirements Reports Inspections Print Status History Linked Users NOTs COIs

Is the project located within a permitted Phase I or Phase II Municipal Separate Storm Sewer System (MS4) area?

**Note: Non-traditional small MS4s that lie within a Phase I or II MS4 area but are NOT designated must comply with the Construction General Permit post construction calculator.**

Does the Phase I or Phase II MS4 have an approved Stormwater Management Plan (SWMP) that includes post-construction requirements?

[Upload documentation to demonstrate compliance with the Phase I or Phase II MS4 post-construction requirements](#)

#### Option 2:

Is the project located within a permitted Phase I or Phase II Municipal Separate Storm Sewer System (MS4) area?

**Note: Non-traditional small MS4s that lie within a Phase I or II MS4 area but are NOT designated must comply with the Construction General Permit post construction calculator.**

Does the Phase I or Phase II MS4 have an approved Stormwater Management Plan (SWMP) that includes post-construction requirements?

Will the project use an alternative method to calculate runoff volume or use different site design measures than those listed in the CGP calculator?

Will the project be subdivided into smaller sub-areas or drainage management areas?

**Sub Areas:**

| Sub Area ID                                     | Name | County | Size(acres) | Delete |
|---|------|--------|-------------|--------|
| <input type="button" value="Add New Sub Area"/> |      |        |             |        |





## SMARTS User Guide

### Option 3:

Is the project located within a permitted Phase I or Phase II Municipal Separate Storm Sewer System (MS4) area? Yes ▾

**Note: Non-traditional small MS4s that lie within a Phase I or II MS4 area but are NOT designated must comply with the Construction General Permit post construction calculator.**

Does the Phase I or Phase II MS4 have an approved Stormwater Management Plan (SWMP) that includes post-construction requirements? No ▾

Will the project use an alternative method to calculate runoff volume or use different site design measures than those listed in the CGP calculator? No ▾

Will the project be subdivided into smaller sub-areas or drainage management areas? No ▾

---

**INPUT FOR WATERSHED: Enter watershed details and click on the Compute & Save button.**

I.a. Name:

I.b. County:

I.c. Closest Location:

I.d. Size(acres):

---

**Pre-Construction INPUT**

I.e. Dominant Soil Type:

I.f. Existing Dominant Non-built Land Use Type:

I.g. Existing rooftop impervious area(acres):

I.h. Existing non-rooftop impervious area(acres):

**Post-Construction INPUT**

I.i. Proposed Dominant Non-built Land Use Type:

I.j. Proposed rooftop impervious area(acres):

I.k. Proposed non-rooftop impervious area(acres):

---

**OUTPUT:**

|   |                      |  |                      |
|---|----------------------|--|----------------------|
| O.a. Existing Runoff Curve Number:                                | <input type="text"/> | O.d. Proposed Runoff Curve Number:             | <input type="text"/> |
| O.b. Design Storm(inches):  | <input type="text"/> | O.e. Net Credit of Volume Credits(Cubic feet): | <input type="text"/> |
| O.c. Pre-project Runoff Volume(Cubic Feet):                       | <input type="text"/> | O.f. Post-project Runoff Volume(Cubic Feet):   | <input type="text"/> |
| O.g. Post-project Runoff Volume minus Volume Credits(Cubic Feet): | <input type="text"/> |  |                      |

To delete the watershed please click on the delete button below:

## SMARTS User Guide

**Step 11:** If **Option 3** appears, type in the **INPUT** information for Watershed, Pre-Construction, and Post-Construction. Then press **Compute & Save**.

Is the project located within a permitted Phase I or Phase II Municipal Separate Storm Sewer System (MS4) area? Yes ▾

**Note: Non-traditional small MS4s that lie within a Phase I or II MS4 area but are NOT designated must comply with the Construction General Permit post construction calculator.**

Does the Phase I or Phase II MS4 have an approved Stormwater Management Plan (SWMP) that includes post-construction requirements? No ▾

Will the project use an alternative method to calculate runoff volume or use different site design measures than those listed in the CGP calculator? No ▾

Will the project be subdivided into smaller sub-areas or drainage management areas? No ▾

---

**INPUT FOR WATERSHED:** Enter watershed details and click on the Compute & Save button.

i.a. Name:

i.b. County:

i.c. Closest Location:

i.d. Size(acres):

---

**Pre-Construction INPUT**

i.e. Dominant Soil Type:

i.f. Existing Dominant Non-built Land Use Type:

i.g. Existing rooftop impervious area(acres):

i.h. Existing non-rooftop impervious area(acres):

---

**Post-Construction INPUT**

i.i. Proposed Dominant Non-built Land Use Type:

i.j. Proposed rooftop impervious area(acres):

i.k. Proposed non-rooftop impervious area(acres):

---

**OUTPUT:**

|   |                      |  |                      |
|---|----------------------|--|----------------------|
| O.a. Existing Runoff Curve Number:                                | <input type="text"/> | O.d. Proposed Runoff Curve Number:             | <input type="text"/> |
| O.b. Design Storm(inches):  | <input type="text"/> | O.e. Net Credit of Volume Credits(Cubic feet): | <input type="text"/> |
| O.c. Pre-project Runoff Volume(Cubic Feet):                       | <input type="text"/> | O.f. Post-project Runoff Volume(Cubic Feet):   | <input type="text"/> |
| O.g. Post-project Runoff Volume minus Volume Credits(Cubic Feet): | <input type="text"/> |  |                      |

To delete the watershed please click on the delete button below:



## SMARTS User Guide

**Step 12:** One of the following messages will appear:

If you see: **\*\*\*Pre-project Runoff Volume >= Post-project Runoff Volume. No further calculation is necessary!** You are done with the Post-Construction calculations. Take a screen shot and save for submittal. Select **Save & Continue**.

- OR -

If you see: **\*\*\*Post-project Runoff Volume > Pre-project Runoff Volume. Please perform volume credit calculations by clicking on the link below,** then you must move on to **Step 13**.

**Step 13:** Complete the **Volume Credit Calculator Worksheet**. Click on the runoff reduction measures (porous pavement, tree planting, downspout disconnection, impervious area disconnection, green roof, stream buffer, vegetative swale, rain barrels/cisterns, soil quality) used on the project. Enter in the requested information for each applicable reduction measure and press **Compute & Save** for each measure.

Following is the requested information required for each runoff reduction measure:



## SMARTS User Guide

**Volume Credit Calculator Worksheets:**

**Formula** **Credit(Cubic Feet)**

**A. Pervious Pavement**

| Input  |                 | Output             |
|--|-----------------|--------------------|
| Area of Brick without Grout on less than 12 inches of base with at least 20% void space over soil        | 0 (Square feet) | 0.00 (Square feet) |
| Area of Brick without Grout on more than 12 inches of base with at least 20% void space over soil        | 0 (Square feet) | 0.0 (Square feet)  |
| Area of Cobbles less than 12 inches deep and over soil   | 0 (Square feet) | 0.0 (Square feet)  |
| Area of Cobbles more than 12 inches deep and over soil   | 0 (Square feet) | 0.0 (Square feet)  |
| Area of Reinforced Grass Pavement on less than 12 inches of base with at least 20% void space over soil  | 0 (Square feet) | 0.00 (Square feet) |
| Area of Reinforced Grass Pavement on at least 12 inches of base with at least 20% void space over soil   | 0 (Square feet) | 0.0 (Square feet)  |
| Area of Porous Gravel Pavement on less than 12 inches of base with at least 20% void space over soil     | 0 (Square feet) | 0.00 (Square feet) |
| Area of Porous Gravel Pavement on at least 12 inches of base with at least 20% void space over soil      | 0 (Square feet) | 0.00 (Square feet) |
| Area of Poured Porous Concrete or Asphalt Pavement with less than 4 inches of gravel base (washed stone) | 0 (Square feet) | 0.0 (Square feet)  |
| Area of Poured Porous Concrete or Asphalt Pavement with 4 to 8 inches of gravel base (washed stone)      | 0 (Square feet) | 0.0 (Square feet)  |
| Area of Poured Porous Concrete or Asphalt Pavement with 8 to 12 inches of gravel base (washed stone)     | 0 (Square feet) | 0.0 (Square feet)  |
| Area of Poured Porous Concrete or Asphalt Pavement with 12 or more inches of gravel base (washed stone)  | 0 (Square feet) | 0 (Square feet)    |

**Total Credit Volume:(cubic feet)**

**Compute & Update**

**B. Tree Planting**

| Input   |  | Output        |
|---|--|---------------|
| Number of Proposed Evergreen trees to be planted  |  | (Square feet) |
| Number of Proposed Deciduous trees to be planted  |  | (Square feet) |
| Square feet under an existing tree canopy, that will remain on the property, with an average diameter at 4.5 feet above grade (i.e., diameter at breast height or DBH) is LESS than 12 in diameter  |  | (Square feet) |
| Square feet under an existing tree canopy, that will remain on the property, with an average diameter at 4.5 feet above grade (i.e., diameter at breast height or DBH) is 12 in diameter or GREATER |  | (Square feet) |

**Total Credit Volume(cubic feet):**

**Compute & Update**

**C. Downspout Disconnection**

**Note:** If you answer yes to all questions, all rooftop area draining to each downspout will be subtracted from your proposed rooftop impervious coverage. **Credit will be provided in the Soil Quality Worksheet.**

Do downspouts and any extensions extend at least six feet from a basement and two feet from a crawl space or concrete slab? Select ▼

Is the area of rooftop connecting to each disconnected downspout 600 square feet or less? Select ▼

Is the roof runoff from the design storm event fully contained in a raised bed or planter box, or does it drain as sheet flow to a landscaped area large enough to contain the roof runoff from the design storm event? Select ▼

The Stream Buffer and/or Vegetative Swale credits will not be taken in this sub-watershed area? Select ▼

**Percent of proposed rooftop with disconnected downspouts:(%)**

**Compute & Update**

**Equivalent Volume (cubic feet)**

# SMARTS User Guide

## D. Impervious Area Disconnection

Note: If you answer yes to all questions, all non-rooftop impervious surface area will be subtracted from your proposed non-rooftop impervious coverage. [Credit will be provided in the Soil Quality Worksheet.](#)

Is the maximum contributing impervious flow path less than 75 feet or, if equal or greater than 75 feet, is a storage device (e.g., French drain, bioretention area, gravel trench) implemented to achieve the required disconnection length? Select ▼

Is the impervious area to any one discharge location less than 5000 sq ft? Select ▼

Does the impervious area runoff from the design storm event drain as sheet flow to a landscaped area large enough to contain the runoff? Select ▼

The Stream Buffer credit will not be taken in this sub-watershed area? Select ▼

Percentage of the proposed non-rooftop surface area disconnected(%):

[Compute & Update](#)

Equivalent Volume (cubic feet):

## E. Green Roof

Note: If you answer yes to all questions, 70% of the green roof area will be subtracted from your proposed rooftop impervious coverage.

Is the roof slope less than 15% or does it have a grid to hold the substrate in place until it forms a thick vegetation mat? Select ▼

Has a professional engineer assessed the necessary load reserves and designed a roof structure to meet state and local codes? Select ▼

Is irrigation needed for plant establishment and/or to sustain the green roof during extended dry periods, is the source from stored, recycled, reclaimed, or reused water? Select ▼

Percentage of the proposed rooftop impervious area that is green roof(%):

[Compute & Update](#)

Total Credit Volume (cubic feet):

## F. Stream Buffer

Note: If you answer yes to all questions, you may subtract all impervious surface draining to each stream buffer that has not been addressed using the Downspout and/or Impervious Area Disconnection credits.

[Event runoff](#)

[Sheet Flow](#)

Does runoff enter the floodprone width\* or within 500ft (whichever is larger) of a stream channel as sheet flow? Select ▼

Is the contributing overland slope 5% or less or if greater than 5% is a level spreader used? Select ▼

Is the buffer area protected from vehicle or other traffic barriers to reduce compaction? Select ▼

Will the stream buffer be maintained in an ungraded and uncompacted condition and will the vegetation be maintained in a natural condition? Select ▼

Percentage of the proposed impervious area that will drain into a stream buffer(%):

[Compute & Update](#)

Total Credit Volume (cubic feet):

## G. Vegetative Swale

Note: If you answer yes to all questions, you may subtract all impervious surface draining to each stream buffer that has not been addressed using the Downspout Disconnection credit.

Have all vegetative swales been designed in accordance with treatment control bmp 30(TC-30-Vegetated Swale) from the California Stormwater BMP Handbook, New Development and Redevelopment (available at [www.cabmphandbooks.com](http://www.cabmphandbooks.com))? Select ▼

Is the maximum flow velocity for runoff from the design storm event less than or equal to 1.0 ft per second? Select ▼

Percentage of the proposed impervious area that will drain into a vegetated swale(%):

[Compute & Update](#)

Total Credit Volume (cubic feet):

## SMARTS User Guide

H. Rain Barrels/Cisterns

| Input  |                      |
|--|----------------------|
| Total number of rain barrel(s)/cistern(s)                | <input type="text"/> |
| Average capacity of rain barrel(s)/cistern(s) in Gallons | <input type="text"/> |
| <b>Total Credit Volume:</b> <input type="text"/>         |                      |
| <b>Compute &amp; Update</b>                              |                      |

I. Soil Quality

Note: If the Soil Quality Volume is larger than or equal to the sum of the Downspout Disconnector, ImperVIOUS Disconnector, and Landscape Area Rainfall Volumes, then credit will be provided for the sum (Downspout, ImperVIOUS & Landscape). If this is not true, then credit will be provided for the Soil Quality Volume only.

Will the soils used for landscaping meet the ideal bulk densities listed in the TABLE 1 below? Select ▼

Do you know the area-weighted bulk density within the top 12 inches for soils used for landscaping? Select ▼

Average depth of landscaped soil media (inches):

Total area of the landscaped areas meeting criteria (acres):

**Compute & Update**

Soil Quality Equivalent Volume (cubic feet)

Downspout Disconnector Equivalent Volume (cubic feet)

ImperVIOUS Area Equivalent Volume (cubic feet)

Total Credit Volume (cubic feet)

|  |      |
|--|------|
| Sands, loamy sands                                     | >1.6 |
| Sandy loams, loams                                     | >1.4 |
| Sandy clay loams, loams, clay loams                    | >1.4 |
| silt, silt loams                                       | >1.3 |
| silt loams, silty clay loams                           | >1.1 |
| sandy clays, silty clays, some clay loams(35-45% clay) | >1.1 |
| clays(>45% clay)                                       | <1.1 |

**Step 14:** Take a screen shot and save for submittal. Select **Save & Continue**.



**ATTACHMENT H:**  
OWP LID SIZING TOOL USER GUIDE

## OWP LID Sizing Tool- User Guide

Use the Office of Water Programs online Low Impact Development (LID) Sizing Tool to select and size Stormwater Treatment Measures that meet the sizing requirements described in the MS4 permit. Access the online LID sizing tool at the following link:

<http://www.owp.csus.edu/LIDTool/>. The following steps will need to be completed for *each* Drainage Management Area (DMA).

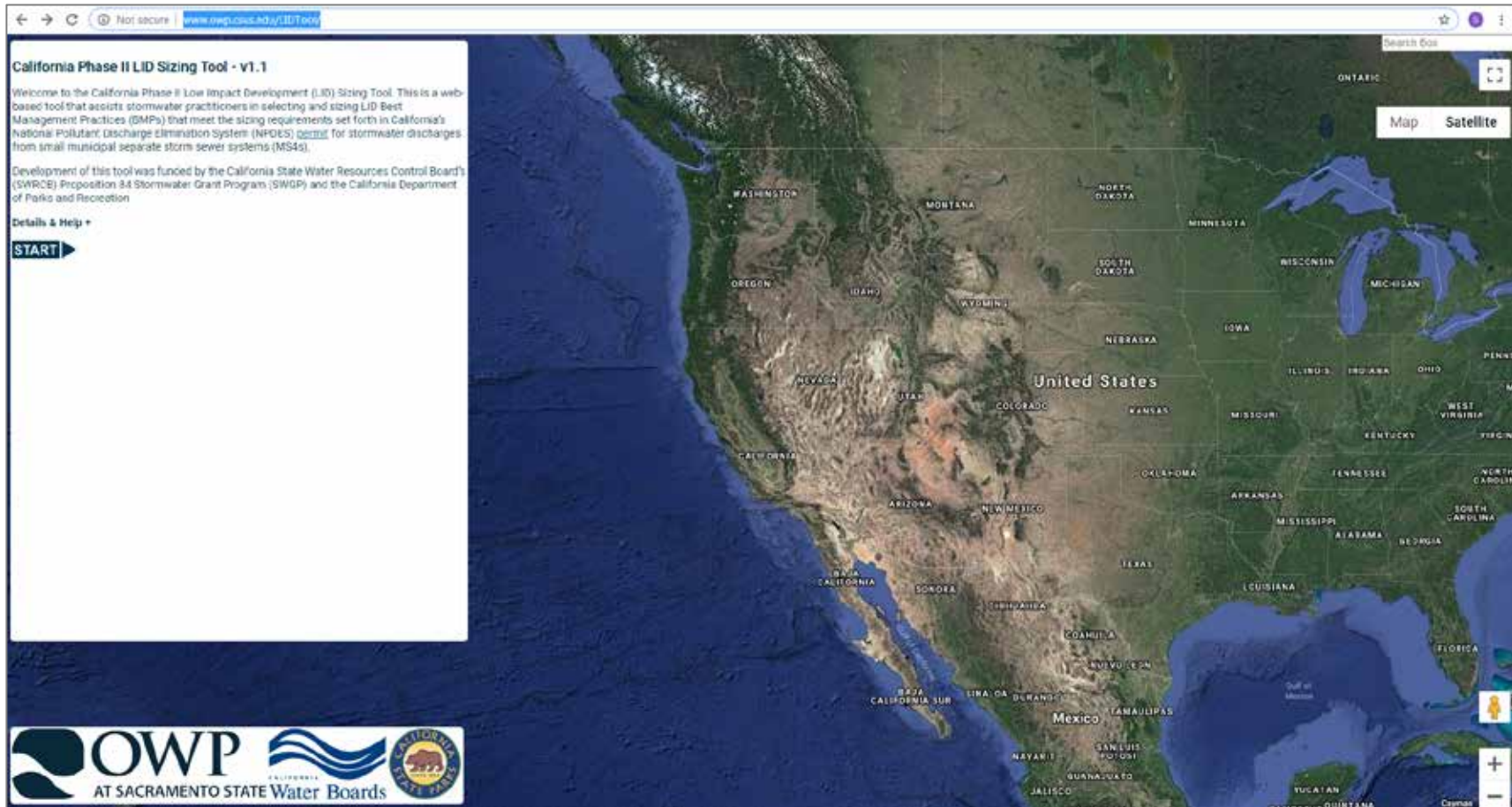

California Phase II LID Sizing Tool - v1.1

Welcome to the California Phase II Low Impact Development (LID) Sizing Tool. This is a web-based tool that assists stormwater practitioners in selecting and sizing LID Best Management Practices (BMPs) that meet the sizing requirements set forth in California's National Pollutant Discharge Elimination System (NPDES) permit for stormwater discharges from small municipal separate storm sewer systems (MS4s).

Development of this tool was funded by the California State Water Resources Control Board's (SWRCE) Proposition 84 Stormwater Grant Program (SWGPP) and the California Department of Parks and Recreation.

Details & Help +

**START**

OWP  
AT SACRAMENTO STATE Water Boards

CALIFORNIA STATE PARKS



# OWP LID Sizing Tool- User Guide

**Step 1:** Select a Climate Station nearest to your project, then click **Next**.

### Step 1 - Select a Climate Station and Project Name

This tool provides results based on 91 climate stations throughout California. Use the drop-down menu to choose the climate station that best represents your project site. Climate stations are also shown on the map to the right. Click on any station on the map to learn its name, years on record, 85th percentile design storm, and other information. You will be able to override the design storm on the following page.

SAN JOSE

If you would like to give your project a name add it to the box below

 Project name (optional)

Stormwater and Schools +

**BACK** **NEXT**

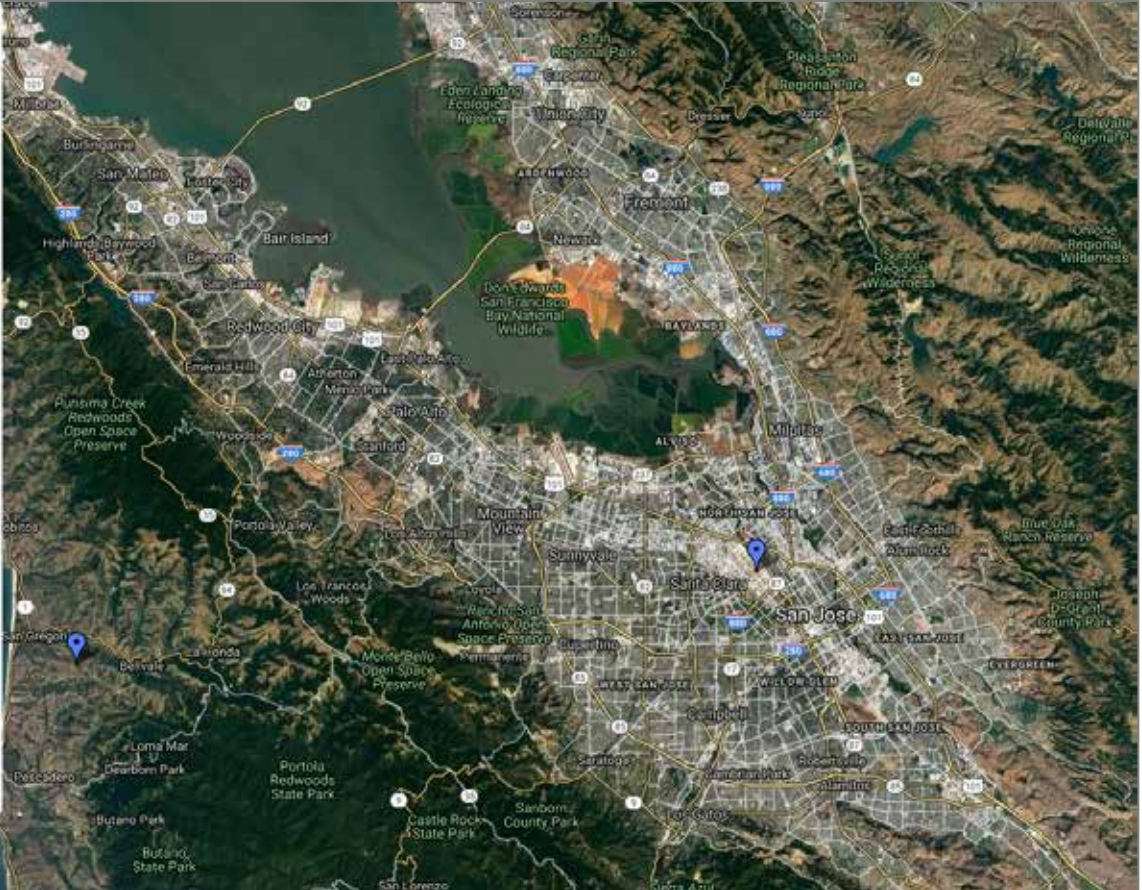

# OWP LID Sizing Tool- User Guide

**Step 2:** Enter your project site's saturated hydraulic conductivity based on on-site field data, then click **Next**.

### Step 2 - Input a saturated hydraulic conductivity

Enter your project site's saturated hydraulic conductivity based on on-site field data.

If you don't know the saturated hydraulic conductivity, check with your local regulator to see if it is acceptable to use estimates from the US Department of Agriculture Natural Resources Conservation Service (USDA NRCS). If it is, you can view the USDA NRCS hydrologic soil group on the map to the right. Click on the color covering your project location to get an estimate of the saturated hydraulic conductivity.

If you want more information on infiltration rates commonly affiliated with different soil hydrologic groups and soil textures expand the "Tables" section below.

**Tables** +

Inches per hour

**BACK** **NEXT**



## OWP LID Sizing Tool- User Guide

**Step 3:** Type in the impervious area of the DMA, then click **Next**.

### Step 3 - Input the impervious area

The CA Phase II NPDES [permit](#) requires that the project site be divided into discrete drainage management areas (DMAs). Runoff from each DMA must be managed using LID BMPs that meet specific sizing criteria specified in the permit. The tool assumes that the DMA consists of a 100% impervious catchment draining to a LID BMP. Input the size of the impervious catchment of the DMA of interest for your project.

You can use your own measured area or calculate an area using the measure tool below.

Measure Tool +

1000  Square Feet

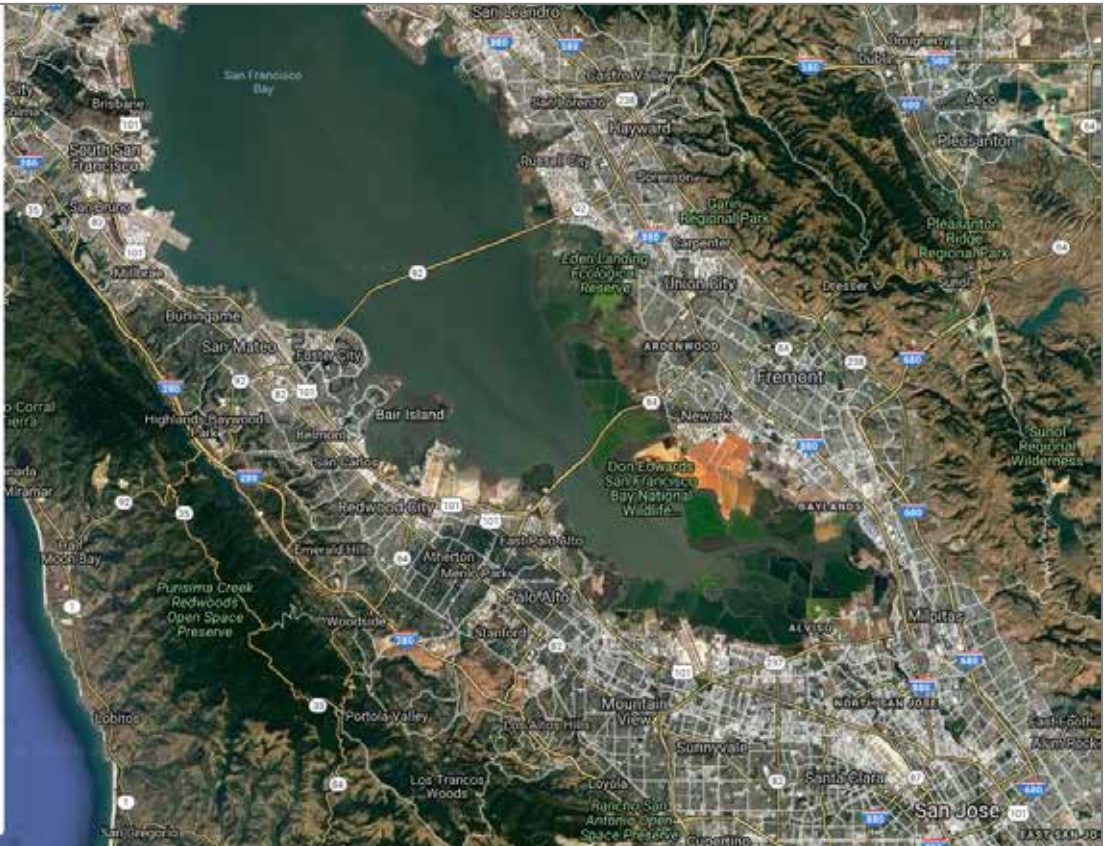

# OWP LID Sizing Tool- User Guide

**Step 4:** Type in the 85<sup>th</sup> percentile design storm depth in inches. This will be auto-calculated based on the location previously selected. Click **Next**.

**Step 4 - Input the Design Storm**

|                                  |                  |
|----------------------------------|------------------|
| Climate station                  | SAN JOSE         |
| Saturated hydraulic conductivity | 0.03 In/hr       |
| Impervious area                  | 1000 square feet |

Select a design storm depth in inches (The 85th percentile design storm for this location is: 0.57 in)

inches

← BACK
NEXT →

**Step 5:** Type in the area (SF) devoted to each Site Design Runoff Reduction Measure selected in **Attachment E** (Site Design Runoff Reduction Measure Checklists) of VTA’s Landscaping and Design Criteria Manual. Click on the **LID BMP Types** or **Instructions for Site Design Measures** for descriptions of each type of Runoff Reduction Measure. Note the percent accomplished from the Site Design Runoff Reduction Measures. Click **Next**.

**Step 5 - Site Design Measures**

|                                  |                  |  |  |
|----------------------------------|------------------|--|--|
| Climate station                  | SAN JOSE         |  |  |
| Saturated hydraulic conductivity | 0.03 in/hr       |  |  |
| Impervious area                  | 1000 square feet |  |  |
| Design storm                     | 0.57 in          |  |  |

Site Design Measures (SDMs) must first be implemented to the extent technically feasible before implementing Storm Water Treatment Measures (SWTMs). SDMs must be sized using the 85th percentile, 24-hour storm, or another design storm as adopted by local regulators.

Site Design Measures Using a Design Storm of 0.57 inches

| LID BMP Type          | Area Needed (square feet) | Area Available (square feet)                              | Percent Accomplished |
|-----------------------|---------------------------|---|----------------------|
| Prop. Pavement        | 278.00                    | <input style="width: 50px;" type="text" value="200.00"/>  | 71.94                |
| Imp. Amended 6"       | 413.00                    | <input style="width: 50px;" type="text" value="0.00"/>    | 0.00                 |
| Imp. Amended 12"      | 168.00                    | <input style="width: 50px;" type="text" value="0.00"/>    | 0.00                 |
| Imp. Amended 18"      | 105.00                    | <input style="width: 50px;" type="text" value="10"/>      | 9.52                 |
| Grate Amended 6"      | 413.00                    | <input style="width: 50px;" type="text" value="0.00"/>    | 0.00                 |
| Grate Amended 12"     | 168.00                    | <input style="width: 50px;" type="text" value="0.00"/>    | 0.00                 |
| Grate Amended 18"     | 105.00                    | <input style="width: 50px;" type="text" value="0.00"/>    | 0.00                 |
| Curbs and Low Storage | 43.05 sf                  | <input style="width: 50px;" type="text" value="0.00"/> cf | 0.00                 |
| <b>Totals</b>         | <b>210.000</b>            |   | <b>81.47</b>         |

← BACK
NEXT →

Instructions for Site Design Measures +

Footnotes +

Background +

CA Phase II LID Sizing Tool Methods +

# OWP LID Sizing Tool- User Guide

**Step 6:** Select the Stormwater Treatment Measure Method used to size the Stormwater Treatment Measures selected in **Attachment D2** (Stormwater Control Plan for Regulated Projects) of VTA's Landscaping and Design Criteria Manual. **Note:** The **Central Coast Simple Method** should not be selected, as this method is not applicable to VTA projects and is not included in the MS4 permit (2013). Click **Compare Method Results** for a comparison of sizing criteria based on the available methods. Click **Next**.

**Step 6 - Select a Storm Water Treatment Measure Method**

|  |                  |
|--|------------------|
| Climate station                              | SAN JOSE         |
| Saturated hydraulic conductivity             | 0.03 in/hr       |
| Impervious area                              | 1000 square feet |
| Design storm                                 | 0.57 in          |
| Percent accomplished by site design measures | 100.00%          |
| Percent needed                               | 0.00%            |

**Choose a Method:**

- Design Storm**  
This method sizes the LID BMP to treat the selected design storm.
- 80% Capture**  
This method uses continuous simulation to size the LID BMP to capture 80% of the runoff.
- Bioretention Equivalent**  
This method uses continuous simulation to size the LID BMP to match the performance of bioretention cell with 18" of soil and 12" of gravel storage treating 4% of the impervious area.
- Central Coast Simple Method**  
This method is similar to the Design Storm Method, except that for LID BMPs with an underdrain, any storage volume above the underdrain is not credited.

← BACK
NEXT →

---

[Compare Method Results +](#)

---

[Background +](#)

---

[CA Phase II LID Sizing Tool Methods +](#)

---

[Special Notes Regarding the Tables +](#)

# OWP LID Sizing Tool- User Guide

**Step 7:** Type in the area (SF) devoted to each Stormwater Treatment Measure selected in **Attachment D2** (Stormwater Control Plan for Regulated Projects). Click on the **LID BMP Types** or **Instructions for Storm Water Treatment Measures** for descriptions of each type of Stormwater Treatment Measure. Note the percent accomplished from the Stormwater Treatment Measures selected. Click **Next**.

## Step 7 - Use a Storm Water Treatment Measure

|                                  |                  |
|----------------------------------|------------------|
| Climate station                  | SAN JOSE         |
| Saturated hydraulic conductivity | 0.03 in/hr       |
| Impervious area                  | 1000 square feet |
| Design Storm                     | 0.57 inches      |
| Method                           | Design Storm     |

| LID BMP Types   | Area Needed (square feet) | Area Available (square feet)         | Percent Accomplished |
|---|---------------------------|--------------------------------------|----------------------|
| <a href="#">Bioretention Cell - 18" Soil - 12" Gravel Storage</a>                     | 33.83                     | <input type="text" value="10"/>      | 29.56                |
| <a href="#">Bioretention Cell - 18" Soil - 24" Gravel Storage</a>                     | 26.44                     | <input type="text" value="0.00"/>    | 0.00                 |
| <a href="#">Bioretention Cell - 18" Soil - 36" Gravel Storage</a>                     | 21.70                     | <input type="text" value="0.00"/>    | 0.00                 |
| <a href="#">Bioretention Cell - 24" Soil - 12" Gravel Storage</a>                     | 30.21                     | <input type="text" value="0.00"/>    | 0.00                 |
| <a href="#">Bioretention Cell - 24" Soil - 24" Gravel Storage</a>                     | 24.18                     | <input type="text" value="0.00"/>    | 0.00                 |
| <a href="#">Bioretention Cell - 24" Soil - 36" Gravel Storage</a>                     | 20.15                     | <input type="text" value="0.00"/>    | 0.00                 |
| <a href="#">Bioretention Cell - Soil Depth Varies<sup>5</sup> - No Gravel Storage</a> | 218.00                    | <input type="text" value="0.00"/>    | 0.00                 |
| <a href="#">Infiltration Basin - Vegetated</a>  | 356.00                    | <input type="text" value="0.00"/>    | 0.00                 |
| <a href="#">Infiltration Gallery</a>  | 93.64                     | <input type="text" value="0.00"/>    | 0.00                 |
| <a href="#">Infiltration Trench</a>   | 270.00                    | <input type="text" value="0.00"/>    | 0.00                 |
| <a href="#">Overland Flow no amendment</a>  | N/A                       | <input type="text" value="N/A"/>     | N/A                  |
| <a href="#">Porous Pavement</a>   | 278.00                    | <input type="text" value="0.00"/>    | 0.00                 |
| <a href="#">Strip, Amended 6"</a>   | 413.00                    | <input type="text" value="0.00"/>    | 0.00                 |
| <a href="#">Strip, Amended 12"</a>  | 168.00                    | <input type="text" value="0.00"/>    | 0.00                 |
| <a href="#">Strip, Amended 18"</a>  | 105.00                    | <input type="text" value="0.00"/>    | 0.00                 |
| <a href="#">Swale, Amended 6"<sup>6</sup></a>   | 413.00                    | <input type="text" value="0.00"/>    | 0.00                 |
| <a href="#">Swale, Amended 12"<sup>6</sup></a>  | 168.00                    | <input type="text" value="0.00"/>    | 0.00                 |
| <a href="#">Swale, Amended 18"<sup>6</sup></a>  | 105.00                    | <input type="text" value="0.00"/>    | 0.00                 |
| <a href="#">Capture and Use Storage<sup>7</sup></a>                                   | 43.05 cf                  | <input type="text" value="0.00"/> cf | 0.00                 |
| <b>Site Design Measures</b>   |                           | 210.000                              | 81.47                |
| <b>Totals</b>   |                           | 220.000                              | 111.03               |

◀ **BACK** **NEXT** ▶

|   |
|---|
| <a href="#">Instructions for Storm Water Treatment Measures +</a> |
| <a href="#">Footnotes +</a>                                       |
| <a href="#">Background +</a>                                      |
| <a href="#">CA Phase II LID Sizing Tool Methods +</a>             |
| <a href="#">Special Notes Regarding the Tables +</a>              |

## OWP LID Sizing Tool- User Guide

**Step 8:** Ensure that the Total Percent Accomplished is greater than or equal to 100.00. Take a Screen Shot of this Summary and attach it to the Stormwater Control Plan (SWCP).

**Step 8 - Summary**

|                                  |             |
|----------------------------------|-------------|
| Climate station                  | SAN JOSE    |
| Saturated hydraulic conductivity | 0.03 in/hr  |
| Design Storm                     | 0.57 inches |

| Method                             | LID BMP Types                                     | Area Needed (square feet) | Area Available (square feet) | Percent Accomplished | Volume Evaporated (acre-ft/year) | Volume Infiltrated (acre-ft/year) | Volume of Passing Through the Underdrain (acre-ft/year) | Volume Untreated (acre-ft/year) |
|------------------------------------|---|---------------------------|------------------------------|----------------------|----------------------------------|-----------------------------------|---|---------------------------------|
| Site Design Measure - Design Storm | Porous Pavement                                   | 275.00                    | 200.00                       | 71.94                | -                                | -                                 | -   | -                               |
| Site Design Measure - Design Storm | Strip, Amended 18"                                | 105.00                    | 10                           | 9.52                 | -                                | -                                 | -   | -                               |
| Design Storm                       | Bioretention Cell - 18" Soil - 12" Gravel Storage | 33.83                     | 10                           | 29.56                | -                                | -                                 | -   | -                               |
|                                    | <b>Total LID BMP Area</b>                         |                           | 220                          | 111.02               | -                                | -                                 | -   | -                               |
|                                    | <b>Total Impervious Area</b>                      |                           | 1000                         | 0.00                 | -                                | -                                 | -   | -                               |
|                                    | <b>Totals</b>                                     |                           | 1220.00                      | 111.02               | -                                | -                                 | -   | -                               |

**BACK**

Instructions +

Background +

CA Phase II LID Sizing Tool Methods +

Special Notes Regarding the Tables +



**ATTACHMENT I:**  
CAD STANDARD DESIGN CRITERIA





## CAD Standard Design Criteria

### CAD/ GIS Conversion

#### 1. File Procurement:

Client to define and verify drawings to be used for ACAD/GIS conversion and establish a timeline for submittals and deliverables. The complete deliverable process, and timeline for interim submittals, if not already established by Client, or client representative, shall be developed during this early stage of ACAD/GIS conversion development.

As part of check in/out and verifiable QA/QC process, a complete drawing list is required for ACAD/GIS Conversion. This shall be provided by Client and access to these files shall be obligation of Client via a prearranged method of dispersion. The preferred Technical transfer method shall include but not be limited to: Thumb drive, DVD, direct Client and /or Subcontractor Directory access etc. Detailed and dated Documentation (i.e. email, spreadsheets etc.) shall accompany all drawing transfers.

The Designer shall agree at this time, the version of ACAD and GIS programs to be utilized and verify they are compatible. In order to maintain version control and compatibility, all parties involved shall, at earliest opportunity, agree to notify all other project teams, when their particular program version upgrades are scheduled and implemented.

All drawing(s) shall be procured from trustworthy sources (client, reliable subcontractor, etc.). All drawings shall be pre-approved by client to assure viability. It shall be responsibility of Client, and the CAD Technician (or representative) to verify all files have been delivered and are completely operational.

If not, all parties involved shall determine reasons and solutions when and if files are unusable. Immediately upon resolution, the file source (Client etc.) or other designated entity shall resubmit complete and usable files in separate submittal. Each instance shall be documented in order to establish a “lessons learned” process for future submittals.

#### 2. Working directory folder for Conversion drawing development:

As part of the unique working folder structure identification, the “baseline” working Directory folder name shall be labeled “ACAD/GIS conversion”. Only one “baseline” working folder should be required, but a copy of untouched delivered “baseline” folder files, may be placed in a subfolder named (History), in case of file recovery is needed.

As design evolution and submittals takes place, separate folders are to be created. Folder labeled (MISC) shall be made to house \*.bak (backup files), and files used for temporary needs (blocks, text, etc.). Folder labeled (SUBMITTAL) shall be made to contain each of individual submitted files. These submitted files shall be named in accordance with **SECTION 3**.



## CAD Standard Design Criteria

### 3. Populating History and Working Folders

Copy file(s) from utilized Technical transfer method and place into “ACAD/GIS subfolder “History”. Then copy all files into main working folder “ACAD/GIS Conversion”.

From File Manager, or by other preferred method, uniquely rename files. Utilizing each particular System involved and an abbreviated company name. For example, if the firm name is Keish Environments (KE), rename each file (i.e., SD-Conversion-KE.dwg, or SW-Conversion-KE etc.). For submittal purposes, the submittal date shall be added as a suffix. (for example., SW-Conversion-KE-01292019.)

### 4. Receiving of Multiple XREF files obtained through CAD Command e-Transmit (Client Obligation)

Individual files obtained from Client may actually contain several XREFs (Overlay or Attached). Because of the native Directory structure each of the files came from, many of these files may appear as “Not Found” in XREF directory listing. *CAD Command (XR)*: Client shall supply all files associated with this particular Multi-XREF file in a well labeled “bound” ZIP file. This is obtained by running the “e-transmit” routine from ACAD pull down publishing command.

- To open drawing file(s), the extraction process can be done through File Manager. Highlight “bound” ZIP file in Base working directory. A pulldown menu will automatically appear.
- Highlight “EXTRACT ALL”. A single sub folder is automatically generated that will then contain all files required to successfully open the file for utilization.
- Once all files are Extracted, MOVE all extracted files associated with file into “baseline” working folder and delete ZIP folder.

### 5. Open applicable ACAD drawings in Paper and Model Space

- Access ACAD from desktop (or other preferred method) to open files in “baseline” working folder.
- Using CAD Command (PS) or CAD Command: TM set to 1, proceed to Paper Space (usually borders, linework, text, tables etc.).
- Turn “ON” and “THAW” all layers – CAD Command (-LA, O (open), \*, then, Thaw all layers, CAD Command (T) \*. Type CAD Command (REA) to regenerate (CAD lingo for refresh). This makes visible all entities.
- Zoom Extents – CAD command (Z, E) and completely ERASE all entities with “Window” command.
- Once assured no entities are contained in Paper Space, set Zoom scale factor to 0.7 (viewport actually contains more area). Using CAD Command (LIST), create window from upper right to lower left and “Enter”. There should be nothing found.



## CAD Standard Design Criteria

### 6. Establish ACAD/GIS area with a PLINE Border outline in Model Space

- Open drawing in Model Space – Zoom Extents – CAD command (Z,E)
- Make new layer called “G-OUTLINE”. Using ACAD Command for PLINE (PL) draw a line a maximum distance of 25’ from pre-established project boundaries. Both PLINE thickness and color shall be easily visible from Model Space Zoom Extents perspective. (See **Section 11** relating to Plotting)

### 7. Removal of nonessential layers, entities and blocks.

Take note of which of the remaining layer(s) contain elements of required system(s). Using Layer Manager, set current layer to “0”. Turn “OFF” required system layer(s) and Boundary Outline layer. All that should remain will be non-essential (Electrical, Mechanical, Structural, Architectural etc.) layers, hatches, entities and blocks not required for this exercise. Remove them all with ERASE window command. Purge all unused and removed entities, layers, linetypes, etc. and then regen all CAD Command (REA). The screen should be black and empty.

To reverify everything not essential to this exercise has been removed from both inside and outside Boundary Outline layer, Zoom extents. Set Zoom scale factor to 0.7 (viewport contains more area). Using CAD Command (LIST), create window from upper right to lower left and “Enter”. There should be nothing found.

If so, locate entities, (usually it is a stray comma, a piece of line etc., or residual text describing XREF’s not found at 0,0 location). Remove it and redo until nothing is found during List command search

From Layer Manager, Turn ON required system layer(s) and Border outline. The screen should only contain required system(s) and Border outline.

### 8. Reducing Blocks into individual linework

Pertinent system linework may contain blocks, (Manholes, casings etc.). These will need to be “exploded” using CAD Command (E). This process breaks up “block” linework into individual entities though still maintaining block configuration.

Once all pertinent entities have been located, Create a simple layering and colorization convention.

### 9. Adding XREF files (for clarification)

Once all previous associated files have been removed and purged from drawing it may be quite difficult to establish bearings as to location. Adding a viable XREF such as an alignment file is very much encouraged. To add XREF’s, first verify it was part of initial drawings delivered by Client to assure its compatibility. Add layer G-XREF, color 7.

Make sure XREF file has first been cleaned out using purge routines, all linework colors and linetypes are BYLAYER and is located in “baseline” working directory. In order to not be confused with original



## CAD Standard Design Criteria

file, each XREF file shall be renamed to include prefix “Z-” (i.e. Z-X-ALIGNMENT.DWG). This will place XREF(s) at bottom of directory listings, make much easier to locate and will not interfere with any previously named version making it unique to current project needs.

Make sure Model space UCS is set to World (W) and insertion point is at 0,0. Depending on origination (or Discipline) of file, the insertion scaling will be either 1, or 12. This XREF file should overlay System linework. Using Layer Manager, layer G-XREF should then be locked so as to avoid any change in file orientation, size or location.

Since file linework is “BYLAYER” you shall be able to adjust the color of this XREF’s linework to display according to preferences (Backgrounds are usually colored grey (8), other systems can vary according to suggested options shown in **Section 11**)

### 10. Layering, Colorization, Linetypes

**NOTE:** All associated layer coloring **SHALL** to be “BYLAYER”

Since the entities and associative layers involving this manual pertain to water (i.e. blue) it is still a good idea to place other system elements on separate layers and colors (BYLAYER). Though not a requirement for ACAD/GIS conversion itself, it is a good idea to associate each system with vibrant clearly visible colors when plotted. For example, yellow (and related shades) generally looks adequate when shown in ACAD, but has a tendency to not plot with enough visibility to warrant it’s use.

**NOTE:** all associated layer coloring **SHALL** to be “BYLAYER”

With very large project areas the line thickness is vital for visibility. Some experimenting may be required to develop perfect plot, but generally a line thickness of 5 – 10 should give a good indication as to linework legibility and visibility for particular size of project. Line thickness can always be manipulated until desired affect is obtained, just maintain linework, and colors BYLAYER.

When new line work is to be applied, all Line work should be drawn on appropriate Layer as a PLINE. This will minimize the number of entities and be easier to manipulate. Line thickness will vary according to size of plot. The smaller the plot size the thinner the required line thickness.

Generally, line types to be used will be CONTINUOUS. Depending on needs of engineer, other linetype such as dashed, hidden, phantom can be utilized. However, as with line thickness, and color selection, these embellishments are of no consequence for ACAD/GIS conversion. It is only to supply team with an easy to view multisystem check verification on a physically plotted drawing despite viewport scale.

### 11. Plotting

The CAD Technician will be supplied a CTB table named “**Color Full size -Exhibit.ctb**”. In it, plots can be colorized using several various combinations, in order to be uniquely visible to a long plot.

- Colors 1-7 generally always plot black with a slightly varied thickness.



## CAD Standard Design Criteria

- Colors 8,9 generally always plot a light and slightly darker shade of grey.

These particular colors may be sufficient with a relatively small project area (2-300 feet) with one or two viewports on a D or E size drawing. But when a project is miles long this limited color range is not practical.

Besides the nine colors listed above, a line, plotted using Color Full Size-Exhibit.ctb file from associated color pallet will plot as follows:

30 = orange

81 = light green

96 = dark green

131 = cyan

151 light blue

160 = dark blue

180 = magenta

200 = purple

240 = red

### 12. Prepare a Paper space border with viewport(s) and time stamp.

Depending on requirements of engineer(s) and plotter capability, a basic ANSI D size (22"x34") or E-size (34"x44") border line shall be utilized. As a general rule, the actual paper size for each is about an inch larger at borders in order to will allow an approximate 1" bleed area within paper limits. (D=24x36, E=36x48).

In reality however, if a long plot is used, the length of border can be up 10' or more. Engineers shall determine drawing scale, which will determine the length. Though engineers may need to see various scaling options (and dwg sizes) to verify actual requirement. Using *CAD Command OFFSET*, any length can be obtained. The primary driving factor, however, is limited to width of paper used in plotting.

Engineers will also decide title block variations, but, they usually appear, within a block in bottom right corner with desired text inserted as a block. Drawing title, number, dates, engineers' names and company names or logos may apply. Paper space drawing title block text can range .125 and .250 for to .5 or larger for other portions of drawing. A graphic scale, may be desired, depending on viewport scale, but an accurately colorized and labeled legend should always be utilized and located near Border text.

Add an existing border block or create a border using dimensions shown above using new Layer G-BDR, color blue (5). Also create layer G-VP color (30) and assign the "No Plot" option from within Layer Manager (small icon of a red lined printer).



## CAD Standard Design Criteria

Make G-VP layer current and type: MVIEW. Depending on size of border utilized, create a viewport layer either as a 4-corner rectangle or multiple points, so various cuts and corners can be developed. Once the number of viewports and settings have been established, “Lock” G-VP layer so viewports setting cannot be altered.

At all times, not just during submittals, verify, thru established best CAD practices that files are clean, purged, Zoomed to Extent, closed in paper space (if border is present) closed in layer “0”, legible, no stray markings and all entities are “BYLAYER”. Make sure all XREF and Viewport layers are locked so no accidental pan or zoom with make unwanted scaling adjustments.

Always practice good ACAD housekeeping! Make sure only files pertinent to drawings for submittal in “baseline” working directory. All other files need to be relocated to another folder (History, MISC etc.)

### 13. Submittal(s)

Once files have been developed to satisfaction of engineers, it is now time for a submittal. Open file. For extra good measure key in *CAD command (SAVE)*. Then, from ACAD Top ribbon, save file using pulldown “SAVE AS” option. (As indicated in **Section 3**, save file using existing file name, but add date). **Save and Close** file with Paper Space Border.

With newly renamed and dated file open, remove everything in Paper space and Remove all XREF's and Purge all unused entities. All that should remain is system linework in Model Space. Close out in Model Space.

Based upon submittal requirements established at beginning of project, package within preferred pre-arranged media (Thumb Drive, DVD etc.) along with documentation relaying required information.



## **ATTACHMENT J:**

### **POST-CONSTRUCTION STANDARD DETAILS, SPECIFICATIONS, AND GUIDANCE**

The details in this Attachment J are for VTA facilities only. Where there are conflicts with City Standard details or other VTA details, ask VTA MS4 Program Manager and VTA Project Manager for direction

For VTA Facilities, designers should note that industry best practices for storm water design should be used. These include, but are not limited to, the following:

#### NOTES:

1. OVERFLOW DEVICE: INSTALL 5MM PERFORATED GRATE ON OVERFLOW TO COMPLY WITH TRASH CAPTURE REQUIREMENTS. ENSURE OVERFLOW ALLOWS FOR A MIN. OF 6" OF PONDING.
2. PERFORATION PIPE SHOULD HAVE PERFORATIONS SET AT 120 DEGREES AND PERFORATION SLOTS SHOULD BE POINTED DOWN. AT LEAST 2" OF DRAIN ROCK SHOULD COVER THE UNDERDRAIN. THE UNDERDRAIN SHOULD BE PLACED AT A MINIMUM 0.5% SLOPE TO THE STORM DRAIN OR DISCHARGE POINT (UNLESS A FLATTER SLOPE IS ALLOWED BASED UPON SITE-SPECIFIC CONDITIONS).



3. ENERGY DISSIPATER: INSTALL ROCK WITH FILTER FABRIC BENEATH IT (OR EQUIVALENT) AT ALL OPENINGS TO BIORETENTION BASINS. ROCK SHOULD EXTEND PAST OPENING AND DISSIPATE ENERGY SUFFICIENTLY THAT NO EROSION OCCURS IN BIORETENTION SOIL MEDIA.
4. ENSURE THAT VEHICLE STOP/CURB DOES NOT IMPEDE FLOW OF WATER THROUGH THE CURB CUT TO THE BASIN. IF BASIN HAS SURROUNDING CURB, THE DEPTH FROM THE TOP OF THE CURB TO THE MEDIA SHOULD NOT EXCEED HEIGHT OF OVERFLOW BY MORE THAN 2". IF EXCEEDANCE OCCURS, CONSIDER SAFETY MEASURES (I.E . RAILING)
5. SIZING: 4% OF TRIBUTARY DRAINAGE OR 4% OF IMPERVOUS AREAS MAY BE USED AS A GUIDELINE TO SIZE BIORETENTION BASINS
6. CONSIDER IRRIGATION: MINIMIZE OVERSPRAY ENTERING STORM DRAINAGE OVERFLOWS. CONSIDER USE OF DRIP SYSTEM.
7. CONSIDER GROUNDWATER/WATER TABLE IMPACTS EARLY IN DESIGN.
8. NOTE: BASINS THAT DO NOT POND WATER, AND/OR ALLOW "SHORT CIRCUITING" OF G:FLOW DIRECTLY TO THE UNDERDRAIN DUE TO EXCESSIVELY LONG/THIN DIMENSIONS ARE NOT ACCEPTABLE DESIGNS. BASIN DIMENSIONS MUST ALLOW FOR INTENDED PONDING. DESIGNERS MAY BE REQUIRED TO DEMONSTRATE THAT PONDING WILL OCCUR USING FLOW MODELING.
9. PLANTS: SEE VTA'S PLANTING GUIDELINES. DO NOT INSTALL TREES IN BASIN IF IMPERMEABLE LINER IS PRESENT.





## **ATTACHMENT J:**

J1: LID STANDARD DETAILS  
(ADAPTED FROM CASQA)



TABLE OF CONTENTS: ATTACHMENT J

J1 LID STANDARD DETAILS:

STREET SIDE BIORETENTION (WITH PARKING)

STREET SLOPE-SIDED BIORETENTION, WITH PARKING, WITH UNDERDRAIN SW-1

STREET SLOPE-SIDED BIORETENTION, WITH PARKING, NO UNDERDRAIN SW-1A

STREET BIORETENTION PLANTER BOX, WITH PARKING, WITH UNDERDRAIN SW-2

STREET BIORETENTION PLANTER BOX, WITH PARKING, NO UNDERDRAIN SW-2A

STREET SIDE BIORETENTION (NO PARKING)

STREET SLOPE-SIDED BIORETENTION, NO PARKING, WITH UNDERDRAIN SW-3

STREET SLOPE-SIDED BIORETENTION, NO PARKING, NO UNDERDRAIN SW-3A

STREET BIORETENTION PLANTER BOX, NO PARKING, WITH UNDERDRAIN SW-4.

STREET BIORETENTION PLANTER BOX, NO PARKING, NO UNDERDRAIN SW-4A.

STREET BIORETENTION BULB OUT, NO PARKING, NO UNDERDRAIN SW-5

STREET BIORETENTION BULB OUT, MID BLOCK CROSSING PLAN VIEW SW-5.1.

PARKING LOT BIORETENTION

PARKING LOT SLOPE-SIDED BIORETENTION, WITH UNDERDRAIN SW-6

PARKING LOT SLOPE-SIDED BIORETENTION, NO UNDERDRAIN SW-6A

PARKING LOT BIORETENTION PLANTER BOX, WITH UNDERDRAIN SW-7

PARKING LOT BIORETENTION PLANTER BOX, NO UNDERDRAIN SW-7A.

BIOFILTRATION PLANTER BOX (NO PARKING)

PLANTER BOX, NO PARKING SW-9

APPURTENANT STRUCTURES

CURB AND GUTTER SW-12

CURB AND GUTTER SW-12A

DEEP CURB SW-13

THICKENED EDGE SIDEWALK SW-14

FLUSH CURB AT SIDEWALK SW-15

PARKING LOT EDGE OPTIONS SW-16

CURB CUT INLET FOR PLANTERS SW-17

CURB CUT INLET FOR SLOPE SIDED BIORETENTION FACILITY SW-18

INLET WITH GRATE SW-19



GRAVEL CHECK DAM SW-20

CONCRETE CHECK DAM SW-21

OVERFLOW STRUCTURE WITH BEEHIVE GRATE SW-22

OVERFLOW STRUCTURE COLLAR SW-22A

OVERFLOW STRUCTURE WITH SQUARE GRATE SW-23

IMPERMEABLE LINER CONNECTION SW-24

OTHER

PERVIOUS PAVEMENT SW-25

PLANTING INUNDATION ZONES & BIORETENTION PLANT LIST SW-26

DRYWELL STORMWATER BMP SW-27

BIORETENTION STANDARD SPECIFICATION

BIORETENTION STANDARD SPECIFICATION

**J2: VTA BMP GUIDANCE:**

TREE-WELL

SELF-RETAINING AREAS

EXAMPLE 1: SHEET FLOW TO SELF-RETAINING AREA

EXAMPLE 2: DOWNSPOUT DISCONNECTION TO SELF-RETAINING AREA

EXAMPLE 3: VEGETATED SWALE

5MM TRASH SCREEN

SQUARE OR RECTANGLE GRATE

DOMED GRATE

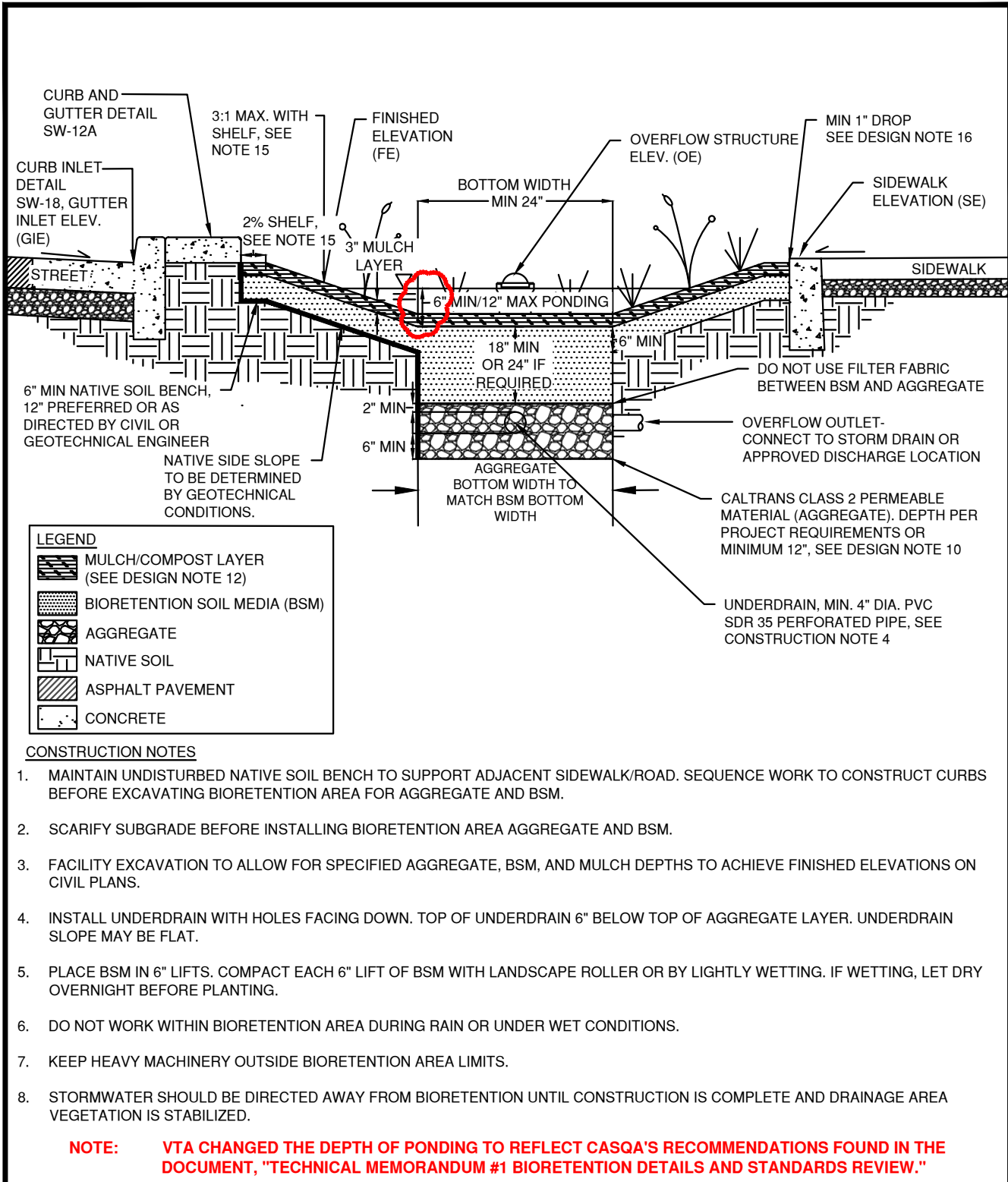

LOW IMPACT DEVELOPMENT STORMWATER MANAGEMENT STANDARD DETAILS

|   |                        |   |                   |
|---|------------------------|---|-------------------|
| DEVELOPED UNDER PROP. 84 GRANT                                | APPROVED BY:           | STREET SLOPE-SIDED BIORETENTION WITH PARKING, WITH UNDERDRAIN | STANDARD PLAN NO. |
|   | VERSION:<br>08/31/2017 |   | SW-1              |
| USE WITH STANDARD SPECIFICATIONS FOR PUBLIC WORK CONSTRUCTION |                        | SHEET 1 OF 2  |                   |



DESIGN NOTES

1. BIORETENTION FACILITY DESIGN SHOULD OPTIMIZE THE FLAT BOTTOM DIMENSIONS (I.E., WIDTH, LENGTH) TO MAXIMIZE THE FUNCTIONAL AREA OF THE FACILITY.
2. CAPTURE AND CONVEY OVERFLOW TO STORM DRAIN SYSTEM (DETAIL SW-22, SW-23). ALTERNATIVELY, CONVEY OVERFLOW TO APPROVED DISCHARGE LOCATION THROUGH OTHER OVERLAND METHODS (IE. CURB CUTS, SIDEWALK UNDERDRAIN, WEIR, ETC.).
3. PROVIDE SPOT ELEVATIONS AT INLETS AND OVERFLOW STRUCTURES ON CIVIL PLANS (FE, OE, GIE, SIE), PER DETAIL SW-18.
4. DUE TO SITE VARIABILITY, TO ENSURE THE LONG-TERM STRUCTURAL STABILITY OF THE BIORETENTION FACILITY AND ANY ADJACENT INFRASTRUCTURE CONSULT WITH A GEOTECHNICAL ENGINEER.
5. A VERTICAL LINER MAY BE USED FOR BIORETENTION FACILITIES TO PREVENT LATERAL FLOW AND TO SEPARATE THE NATIVE SOIL FROM THE BSM AND THE AGGREGATE, HOWEVER A HORIZONTAL LINER SHALL NOT BE USED.
6. DO NOT USE FILTER FABRIC BETWEEN BSM AND AGGREGATE.
7. PROVIDE CAPPED, THREADED PVC CLEANOUT FOR UNDERDRAIN, 4" MIN. DIA. WITH SWEEP BEND.
8. PROVIDE A CLEAN-OUT/OBSERVATION PORT IN EACH FACILITY, PER BIORETENTION TECHNICAL SPECIFICATIONS.
9. ON LONGITUDINAL SLOPE, USE CHECK DAMS (DETAILS SW-20, SW-21)
10. DEPTH OF AGGREGATE DETERMINED BY FACILITY SIZING. IF CALTRANS CLASS 2 PERMEABLE IS NOT AVAILABLE, SUBSTITUTE CLASS 3 PERMEABLE WITH AN OVERLYING 3" DEEP CHOKING LAYER OF EITHER CALTRANS COURSE AGGREGATE 1/2" (NO. 4) OR 3/4" X (NO.4) OPEN-GRADED AGGREGATE.
11. BIORETENTION SOIL MEDIA (BSM) SPECIFICATION PER BIORETENTION TECHNICAL SPECIFICATIONS.
12. PLANT SELECTION PER BIORETENTION TECHNICAL SPECIFICATIONS.
13. MULCH PER BIORETENTION TECHNICAL SPECIFICATIONS.
14. LOCATE ENERGY DISSIPATION AS SPECIFIED IN INLET DETAILS.
15. NATIVE SIDE SLOPE 4:1 (H:V) PREFERRED, 3:1 WITH SHELF. 6" MINIMUM SHELF WITH 2% SLOPE TOWARDS FACILITY ADJACENT TO PEDESTRIAN USE OR CURB UNLESS 4:1 SLOPE PROVIDED.
16. INCLUDE AT LEAST 1" DROP FROM CURB ABOVE MULCH LAYER.
17. AVOID DECORATIVE USE OF COBBLE THAT CAN INTERFERE WITH WITH INFILTRATION.

LOW IMPACT DEVELOPMENT STORMWATER MANAGEMENT STANDARD DETAILS

|   |                        |  |   |
|---|------------------------|--|---|
|  <br>DEVELOPED UNDER PROP. 84 GRANT | APPROVED BY:           | <b>STREET SLOPE-SIDED BIORETENTION WITH<br/>PARKING, WITH UNDERDRAIN</b> | STANDARD PLAN NO.   |
|   | VERSION:<br>08/31/2017 |  | USE WITH STANDARD SPECIFICATIONS FOR PUBLIC WORK CONSTRUCTION |

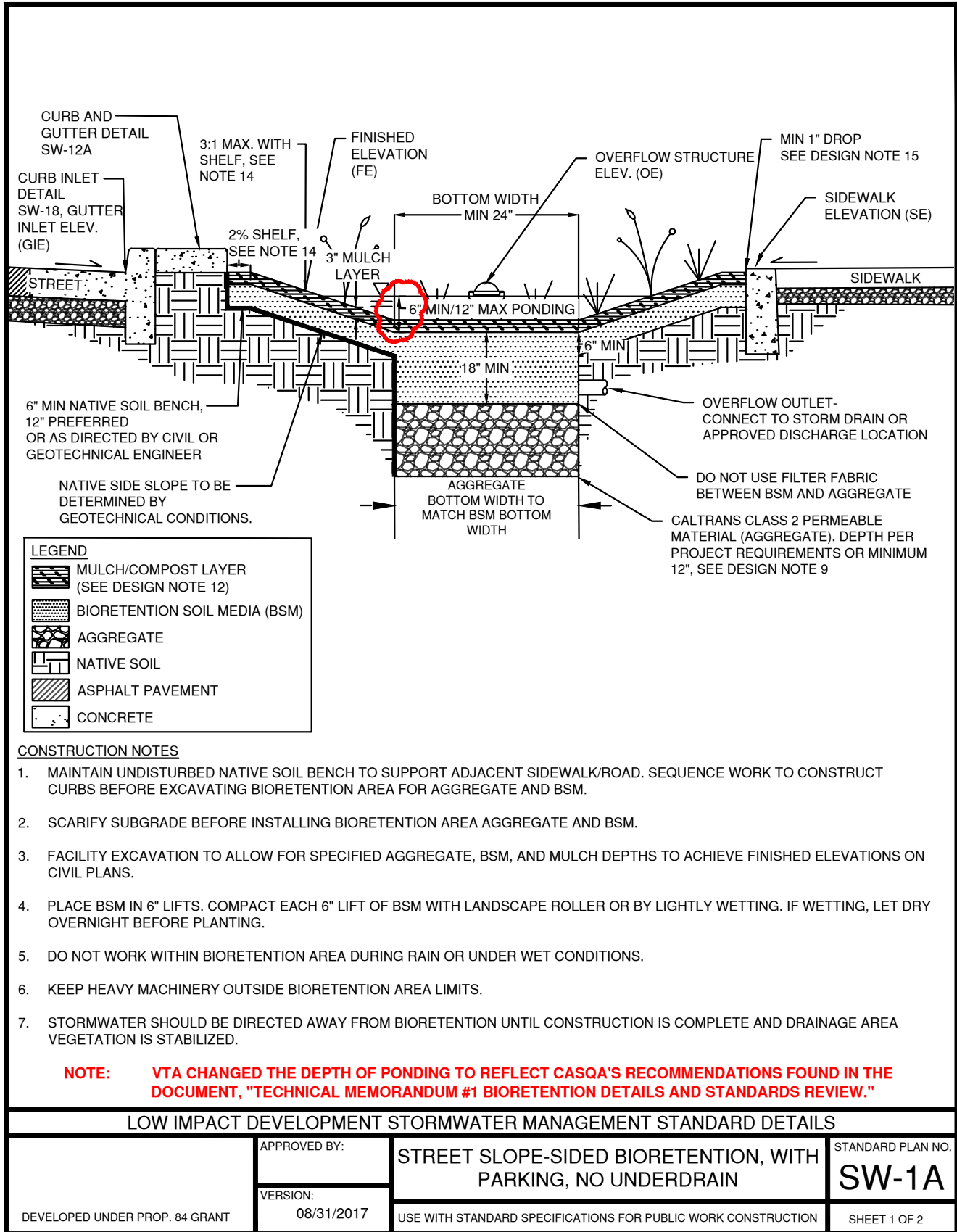



DESIGN NOTES

1. BIORETENTION FACILITY DESIGN SHOULD OPTIMIZE THE FLAT BOTTOM DIMENSIONS (I.E., WIDTH, LENGTH) TO MAXIMIZE THE FUNCTIONAL AREA OF THE FACILITY.
2. CAPTURE AND CONVEY OVERFLOW TO STORM DRAIN SYSTEM (DETAIL SW-22, SW-23). ALTERNATIVELY, CONVEY OVERFLOW TO APPROVED DISCHARGE LOCATION THROUGH OTHER OVERLAND METHODS (IE. CURB CUTS, SIDEWALK UNDERDRAIN, WEIR, ETC.).
3. PROVIDE SPOT ELEVATIONS AT INLETS AND OVERFLOW STRUCTURES ON CIVIL PLANS (FE, OE, GIE, SIE), PER DETAIL SW-18.
4. DUE TO SITE VARIABILITY, TO ENSURE THE LONG-TERM STRUCTURAL STABILITY OF THE BIORETENTION FACILITY AND ANY ADJACENT INFRASTRUCTURE CONSULT WITH A GEOTECHNICAL ENGINEER.
5. A VERTICAL LINER MAY BE USED FOR BIORETENTION FACILITIES TO PREVENT LATERAL FLOW AND TO SEPARATE THE NATIVE SOIL FROM THE BSM AND THE AGGREGATE, HOWEVER A HORIZONTAL LINER SHALL NOT BE USED.
6. DO NOT USE FILTER FABRIC BETWEEN BSM AND AGGREGATE.
7. PROVIDE A CLEAN-OUT/OBSERVATION PORT IN EACH FACILITY, PER BIORETENTION TECHNICAL SPECIFICATIONS.
8. ON LONGITUDINAL SLOPE, USE CHECK DAMS (DETAILS SW-20, SW-21)
9. USE AND DEPTH OF AGGREGATE DETERMINED BY FACILITY SIZING. IF CALTRANS CLASS 2 PERMEABLE IS NOT AVAILABLE, SUBSTITUTE CLASS 3 PERMEABLE WITH AN OVERLYING 3" DEEP CHOKING LAYER OF EITHER CALTRANS COURSE AGGREGATE 1/2" (NO. 4) OR 3/4" X (NO. 4) OPEN-GRADED AGGREGATE.
10. BIORETENTION SOIL MEDIA (BSM) SPECIFICATION PER BIORETENTION TECHNICAL SPECIFICATIONS.
11. PLANT SELECTION PER BIORETENTION TECHNICAL SPECIFICATIONS.
12. MULCH PER BIORETENTION TECHNICAL SPECIFICATIONS.
13. LOCATE ENERGY DISSIPATION AS SPECIFIED IN INLET DETAILS.
14. NATIVE SIDE SLOPE 4:1 (H:V) PREFERRED, 3:1 WITH SHELF. 6" MINIMUM SHELF WITH 2% SLOPE TOWARDS FACILITY ADJACENT TO PEDESTRIAN USE OR CURB UNLESS 4:1 SLOPE PROVIDED.
15. INCLUDE AT LEAST 1" DROP FROM CURB ABOVE MULCH LAYER.
16. AVOID DECORATIVE USE OF COBBLE THAT CAN INTERFERE WITH WITH INFILTRATION.

LOW IMPACT DEVELOPMENT STORMWATER MANAGEMENT STANDARD DETAILS

|   |                        |   |   |
|---|------------------------|---|---|
|   <p>DEVELOPED UNDER PROP. 84 GRANT</p> | APPROVED BY:           | <p><b>STREET SLOPE-SIDED BIORETENTION, WITH PARKING, NO UNDERDRAIN</b></p> <p>USE WITH STANDARD SPECIFICATIONS FOR PUBLIC WORK CONSTRUCTION</p> | STANDARD PLAN NO.                       |
|   | VERSION:<br>08/31/2017 |   | <p><b>SW-1A</b></p> <p>SHEET 2 OF 2</p> |

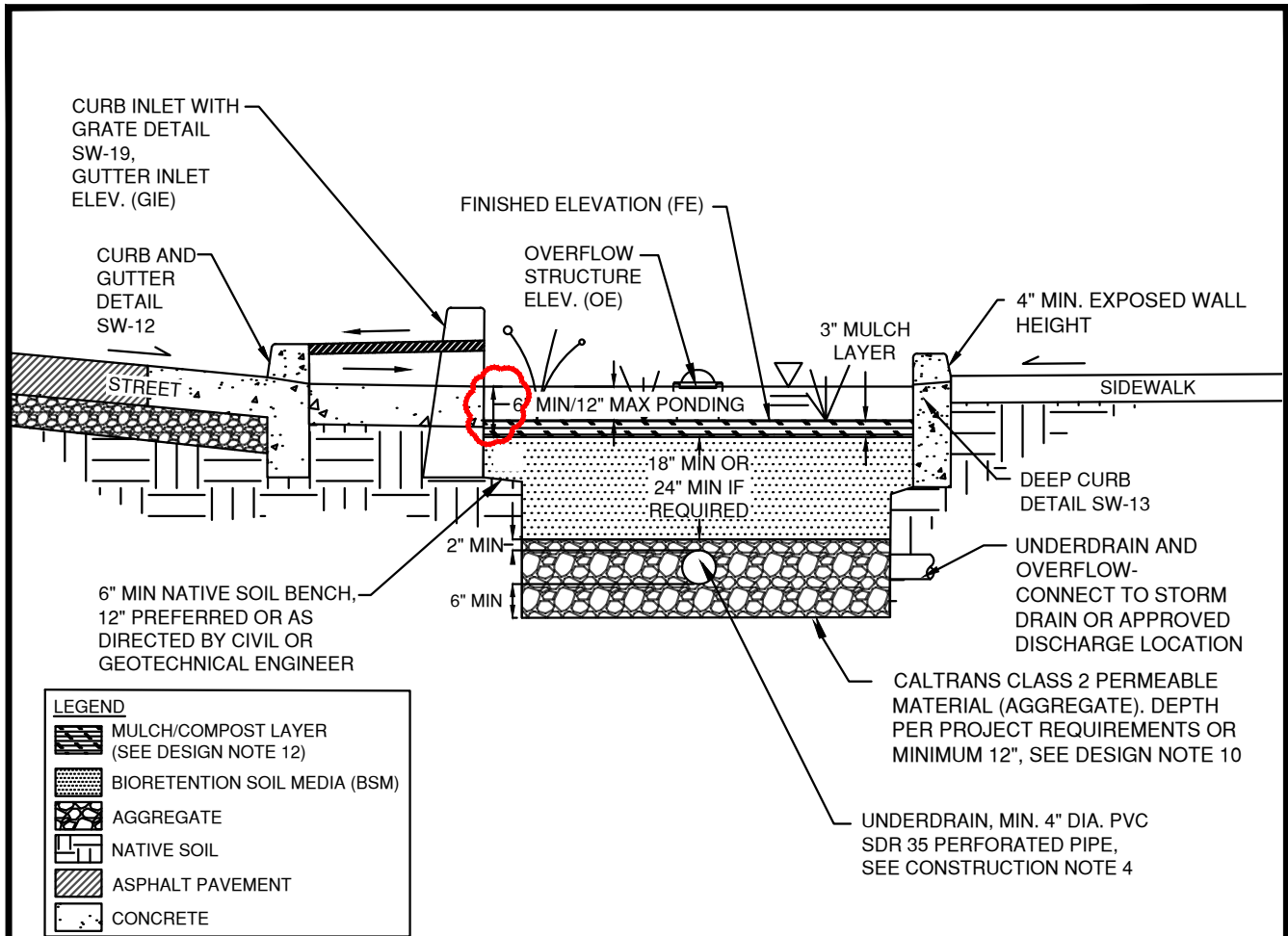

**CONSTRUCTION NOTES**

1. MAINTAIN UNDISTURBED NATIVE SOIL BENCH TO SUPPORT ADJACENT SIDEWALK/ROAD. SEQUENCE WORK TO CONSTRUCT CURBS BEFORE EXCAVATING BIORETENTION AREA FOR AGGREGATE AND BSM.
2. SCARIFY SUBGRADE BEFORE INSTALLING BIORETENTION AREA AGGREGATE AND BSM.
3. FACILITY EXCAVATION TO ALLOW FOR SPECIFIED AGGREGATE, BSM, AND MULCH DEPTHS TO ACHIEVE FINISHED ELEVATIONS ON CIVIL PLANS.
4. INSTALL UNDERDRAIN WITH HOLES FACING DOWN. TOP OF UNDERDRAIN 6" BELOW TOP OF AGGREGATE LAYER. UNDERDRAIN SLOPE MAY BE FLAT.
5. COMPACT EACH 6" LIFT OF BSM WITH LANDSCAPE ROLLER OR BY LIGHTLY WETTING. IF WETTING, LET DRY OVERNIGHT BEFORE PLANTING.
6. DO NOT WORK WITHIN BIORETENTION AREA DURING RAIN OR UNDER WET CONDITIONS.
7. KEEP HEAVY MACHINERY OUTSIDE BIORETENTION AREA LIMITS.
8. STORMWATER SHOULD BE DIRECTED AWAY FROM BIORETENTION UNTIL CONSTRUCTION IS COMPLETE AND DRAINAGE AREA VEGETATION IS STABILIZED.

**NOTE:** VTA CHANGED THE DEPTH OF PONDING TO REFLECT CASQA'S RECOMMENDATIONS FOUND IN THE DOCUMENT, "TECHNICAL MEMORANDUM #1 BIORETENTION DETAILS AND STANDARDS REVIEW."

**LOW IMPACT DEVELOPMENT STORMWATER MANAGEMENT STANDARD DETAILS**

|                                |                        |   |                   |
|--------------------------------|------------------------|---|-------------------|
| DEVELOPED UNDER PROP. 84 GRANT | APPROVED BY:           | STREET BIORETENTION PLANTER BOX,<br>WITH PARKING, WITH UNDERDRAIN | STANDARD PLAN NO. |
|                                | VERSION:<br>08/31/2017 |   | SW-2              |
|                                |                        | USE WITH STANDARD SPECIFICATIONS FOR PUBLIC WORK CONSTRUCTION     | SHEET 1 OF 2      |





DESIGN NOTES

1. BIORETENTION FACILITY DESIGN SHOULD OPTIMIZE THE FLAT BOTTOM DIMENSIONS (I.E., WIDTH, LENGTH) TO MAXIMIZE THE FUNCTIONAL AREA OF THE FACILITY.
2. CAPTURE AND CONVEY OVERFLOW TO STORM DRAIN SYSTEM (DETAIL SW-22, SW-23). ALTERNATIVELY, CONVEY OVERFLOW TO APPROVED DISCHARGE LOCATION THROUGH OTHER OVERLAND METHODS (IE. CURB CUTS, SIDEWALK UNDERDRAIN, WEIR, ETC.).
3. PROVIDE SPOT ELEVATIONS AT INLETS AND OVERFLOW STRUCTURES ON CIVIL PLANS (FE, OE, GIE, SIE), PER DETAIL SW-18.
4. DUE TO SITE VARIABILITY, TO ENSURE THE LONG-TERM STRUCTURAL STABILITY OF THE BIORETENTION FACILITY AND ANY ADJACENT INFRASTRUCTURE CONSULT WITH A GEOTECHNICAL ENGINEER.
5. A VERTICAL LINER MAY BE USED FOR BIORETENTION FACILITIES TO PREVENT LATERAL FLOW AND TO SEPARATE THE NATIVE SOIL FROM THE BSM AND THE AGGREGATE, HOWEVER A HORIZONTAL LINER SHALL NOT BE USED.
6. DO NOT USE FILTER FABRIC BETWEEN BSM AND AGGREGATE.
7. PROVIDE CAPPED, THREADED PVC CLEANOUT FOR UNDERDRAIN, 4" MIN. DIA. WITH SWEEP BEND.
8. PROVIDE A CLEAN-OUT/OBSERVATION PORT IN EACH FACILITY, PER BIORETENTION TECHNICAL SPECIFICATIONS.
9. ON LONGITUDINAL SLOPE, USE CHECK DAMS (DETAILS SW-20, SW-21)
10. USE AND DEPTH OF AGGREGATE DETERMINED BY FACILITY SIZING. IF CALTRANS CLASS 2 PERMEABLE IS NOT AVAILABLE, SUBSTITUTE CLASS 3 PERMEABLE WITH AN OVERLYING 3" DEEP CHOKING LAYER OF EITHER CALTRANS COURSE AGGREGATE 1/2" (NO. 4) OR 3/4" X (NO. 4) OPEN-GRADED AGGREGATE.
11. BIORETENTION SOIL MEDIA (BSM) SPECIFICATION PER BIORETENTION TECHNICAL SPECIFICATIONS.
12. PLANT SELECTION PER BIORETENTION TECHNICAL SPECIFICATIONS.
13. MULCH PER BIORETENTION TECHNICAL SPECIFICATIONS.
14. LOCATE ENERGY DISSIPATION AS SPECIFIED IN INLET DETAILS.
15. AVOID DECORATIVE USE OF COBBLE THAT CAN INTERFERE WITH WITH INFILTRATION.

LOW IMPACT DEVELOPMENT STORMWATER MANAGEMENT STANDARD DETAILS

|   |                        |   |   |
|---|------------------------|---|---|
|  <br>DEVELOPED UNDER PROP. 84 GRANT | APPROVED BY:           | STREET BIORETENTION PLANTER BOX,<br>WITH PARKING, WITH UNDERDRAIN | STANDARD PLAN NO.   |
|   | VERSION:<br>08/31/2017 |   | USE WITH STANDARD SPECIFICATIONS FOR PUBLIC WORK CONSTRUCTION |

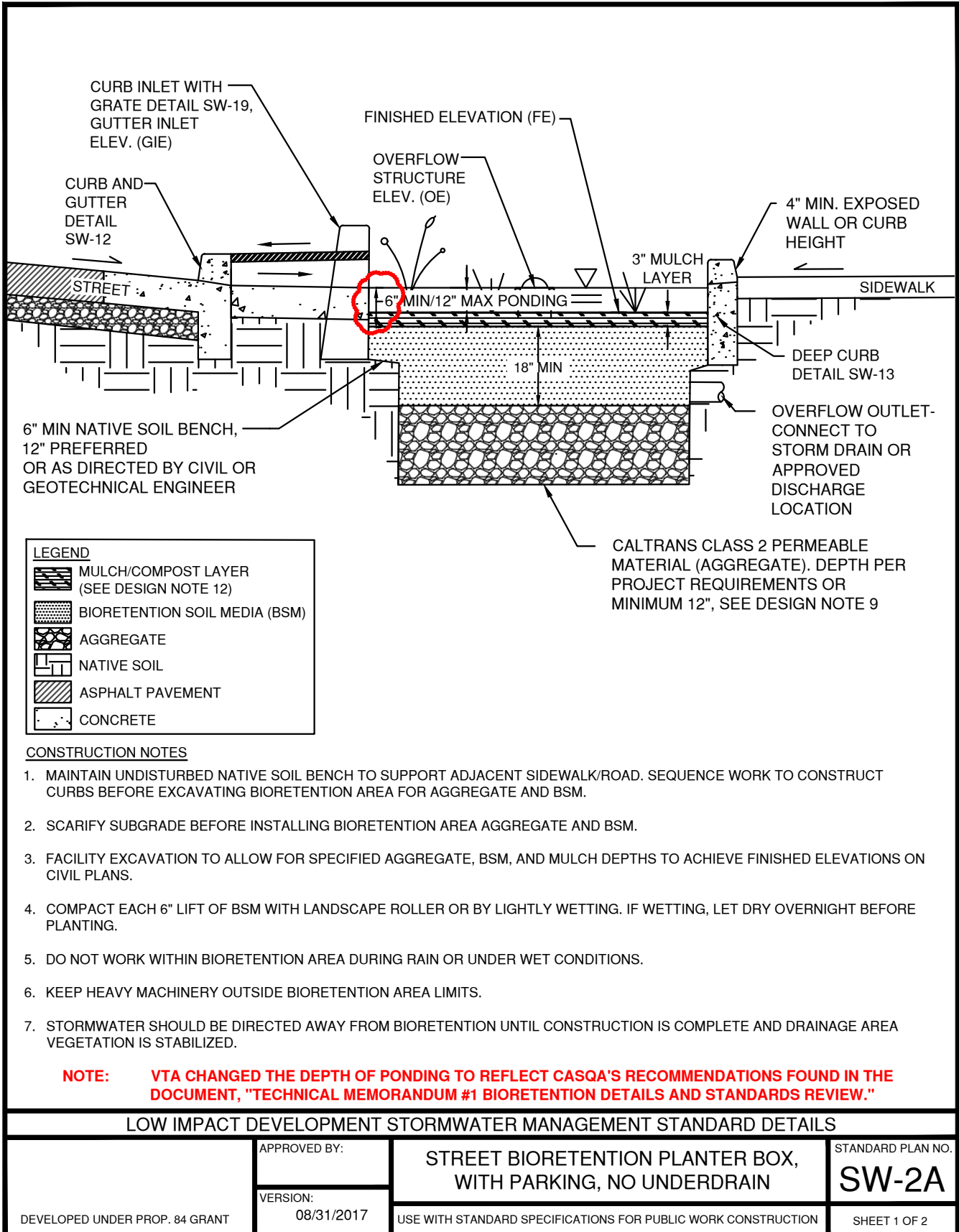



DESIGN NOTES

1. BIORETENTION FACILITY DESIGN SHOULD OPTIMIZE THE FLAT BOTTOM DIMENSIONS (I.E., WIDTH, LENGTH) TO MAXIMIZE THE FUNCTIONAL AREA OF THE FACILITY.
2. CAPTURE AND CONVEY OVERFLOW TO STORM DRAIN SYSTEM (DETAIL SW-22, SW-23). ALTERNATIVELY, CONVEY OVERFLOW TO APPROVED DISCHARGE LOCATION THROUGH OTHER OVERLAND METHODS (IE. CURB CUTS, SIDEWALK UNDERDRAIN, WEIR, ETC.).
3. PROVIDE SPOT ELEVATIONS AT INLETS AND OVERFLOW STRUCTURES ON CIVIL PLANS (FE, OE, GIE, SIE), PER DETAIL SW-18.
4. DUE TO SITE VARIABILITY, TO ENSURE THE LONG-TERM STRUCTURAL STABILITY OF THE BIORETENTION FACILITY AND ANY ADJACENT INFRASTRUCTURE CONSULT WITH A GEOTECHNICAL ENGINEER.
5. A VERTICAL LINER MAY BE USED FOR BIORETENTION FACILITIES TO PREVENT LATERAL FLOW AND TO SEPARATE THE NATIVE SOIL FROM THE BSM AND THE AGGREGATE, HOWEVER A HORIZONTAL LINER SHALL NOT BE USED.
6. DO NOT USE FILTER FABRIC BETWEEN BSM AND AGGREGATE.
7. PROVIDE A CLEAN-OUT/OBSERVATION PORT IN EACH FACILITY, PER BIORETENTION TECHNICAL SPECIFICATIONS.
8. ON LONGITUDINAL SLOPE, USE CHECK DAMS (DETAILS SW-20, SW-21)
9. USE AND DEPTH OF AGGREGATE DETERMINED BY FACILITY SIZING. IF CALTRANS CLASS 2 PERMEABLE IS NOT AVAILABLE, SUBSTITUTE CLASS 3 PERMEABLE WITH AN OVERLYING 3" DEEP CHOKING LAYER OF EITHER CALTRANS COURSE AGGREGATE 1/2" (NO. 4) OR 3/4" X (NO. 4) OPEN-GRADED AGGREGATE.
10. BIORETENTION SOIL MEDIA (BSM) SPECIFICATION PER BIORETENTION TECHNICAL SPECIFICATIONS.
11. PLANT SELECTION PER BIORETENTION TECHNICAL SPECIFICATIONS.
12. MULCH PER BIORETENTION TECHNICAL SPECIFICATIONS.
13. LOCATE ENERGY DISSIPATION AS SPECIFIED IN INLET DETAILS.
14. AVOID DECORATIVE USE OF COBBLE THAT CAN INTERFERE WITH WITH INFILTRATION.

LOW IMPACT DEVELOPMENT STORMWATER MANAGEMENT STANDARD DETAILS

|   |                        |   |                   |
|---|------------------------|---|-------------------|
|  <br>DEVELOPED UNDER PROP. 84 GRANT | APPROVED BY:           | STREET BIORETENTION PLANTER BOX,<br>WITH PARKING, NO UNDERDRAIN | STANDARD PLAN NO. |
|   | VERSION:<br>08/31/2017 |   | <b>SW-2A</b>      |
|   |                        | USE WITH STANDARD SPECIFICATIONS FOR PUBLIC WORK CONSTRUCTION   |                   |

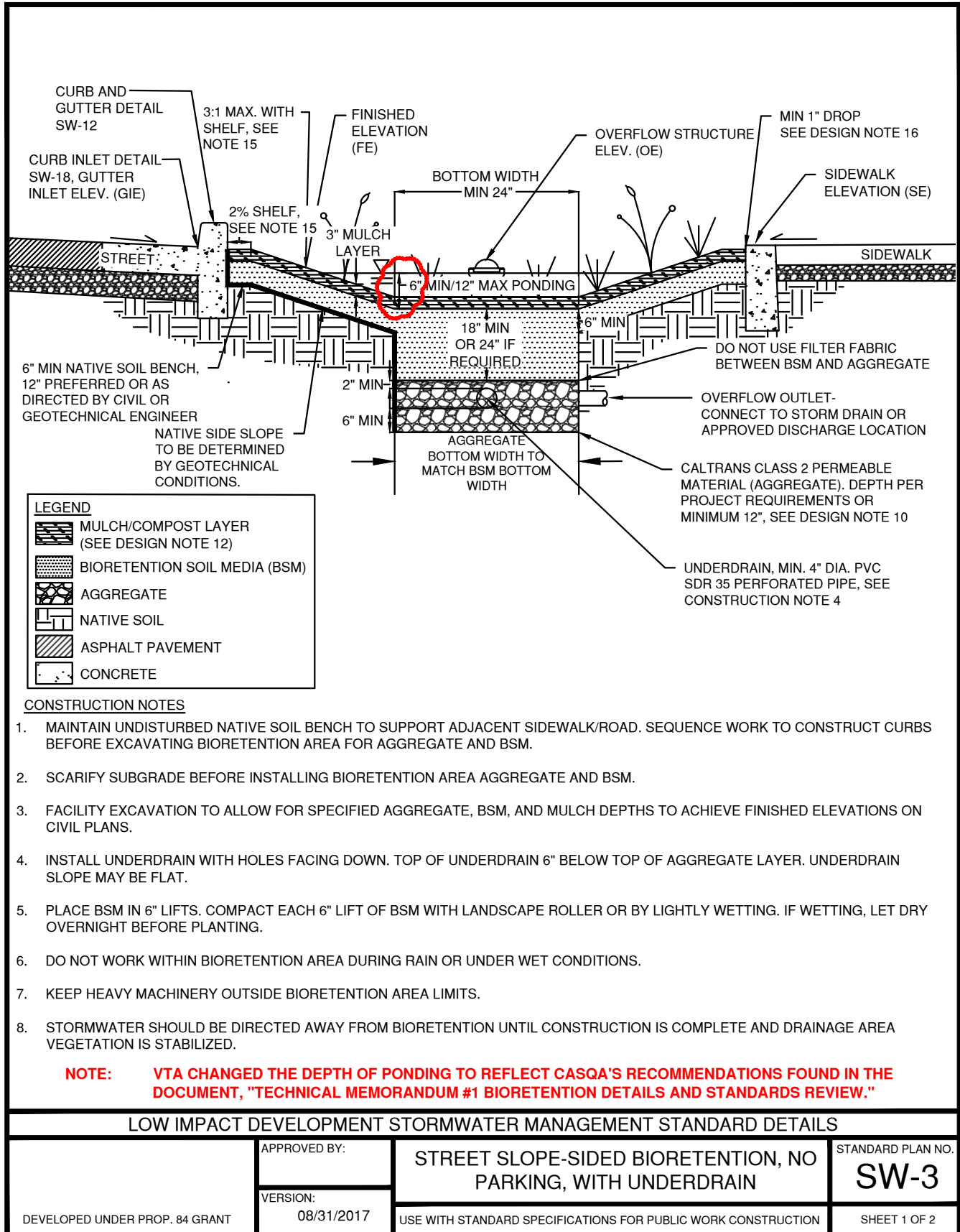



**DESIGN NOTES**

1. BIORETENTION FACILITY DESIGN SHOULD OPTIMIZE THE FLAT BOTTOM DIMENSIONS (I.E., WIDTH, LENGTH) TO MAXIMIZE THE FUNCTIONAL AREA OF THE FACILITY.
2. CAPTURE AND CONVEY OVERFLOW TO STORM DRAIN SYSTEM (DETAIL SW-22, SW-23). ALTERNATIVELY, CONVEY OVERFLOW TO APPROVED DISCHARGE LOCATION THROUGH OTHER OVERLAND METHODS (IE. CURB CUTS, SIDEWALK UNDERDRAIN, WEIR, ETC.).
3. PROVIDE SPOT ELEVATIONS AT INLETS AND OVERFLOW STRUCTURES ON CIVIL PLANS (FE, OE, GIE, SIE), PER DETAIL SW-18.
4. DUE TO SITE VARIABILITY, TO ENSURE THE LONG-TERM STRUCTURAL STABILITY OF THE BIORETENTION FACILITY AND ANY ADJACENT INFRASTRUCTURE CONSULT WITH A GEOTECHNICAL ENGINEER.
5. A VERTICAL LINER MAY BE USED FOR BIORETENTION FACILITIES TO PREVENT LATERAL FLOW AND TO SEPARATE THE NATIVE SOIL FROM THE BSM AND THE AGGREGATE, HOWEVER A HORIZONTAL LINER SHALL NOT BE USED.
6. DO NOT USE FILTER FABRIC BETWEEN BSM AND AGGREGATE.
7. PROVIDE CAPPED, THREADED PVC CLEANOUT FOR UNDERDRAIN, 4" MIN. DIA. WITH SWEEP BEND.
8. PROVIDE A CLEAN-OUT/OBSERVATION PORT IN EACH FACILITY, PER BIORETENTION TECHNICAL SPECIFICATIONS.
9. ON LONGITUDINAL SLOPE, USE CHECK DAMS (DETAILS SW-20, SW-21)
10. DEPTH OF AGGREGATE DETERMINED BY FACILITY SIZING. IF CALTRANS CLASS 2 PERMEABLE IS NOT AVAILABLE, SUBSTITUTE CLASS 3 PERMEABLE WITH AN OVERLYING 3" DEEP CHOKING LAYER OF EITHER CALTRANS COURSE AGGREGATE 1/2" (NO. 4) OR 3/4" X (NO.4) OPEN-GRADED AGGREGATE.
11. BIORETENTION SOIL MEDIA (BSM) SPECIFICATION PER BIORETENTION TECHNICAL SPECIFICATIONS.
12. PLANT SELECTION PER BIORETENTION TECHNICAL SPECIFICATIONS.
13. MULCH PER BIORETENTION TECHNICAL SPECIFICATIONS.
14. LOCATE ENERGY DISSIPATION AS SPECIFIED IN INLET DETAILS.
15. NATIVE SIDE SLOPE 4:1 (H:V) PREFERRED, 3:1 WITH SHELF. 6" MINIMUM SHELF WITH 2% SLOPE TOWARDS FACILITY ADJACENT TO PEDESTRIAN USE OR CURB UNLESS 4:1 SLOPE PROVIDED.
16. INCLUDE AT LEAST 1" DROP FROM CURB ABOVE MULCH LAYER.
17. AVOID DECORATIVE USE OF COBBLE THAT CAN INTERFERE WITH WITH INFILTRATION.

**LOW IMPACT DEVELOPMENT STORMWATER MANAGEMENT STANDARD DETAILS**

|   |                        |   |  |
|---|------------------------|---|--|
|   <p>DEVELOPED UNDER PROP. 84 GRANT</p> | APPROVED BY:           | <p><b>STREET SLOPE-SIDED BIORETENTION, NO PARKING, WITH UNDERDRAIN</b></p> <p>USE WITH STANDARD SPECIFICATIONS FOR PUBLIC WORK CONSTRUCTION</p> | STANDARD PLAN NO.                      |
|   | VERSION:<br>08/31/2017 |   | <p><b>SW-3</b></p> <p>SHEET 2 OF 2</p> |

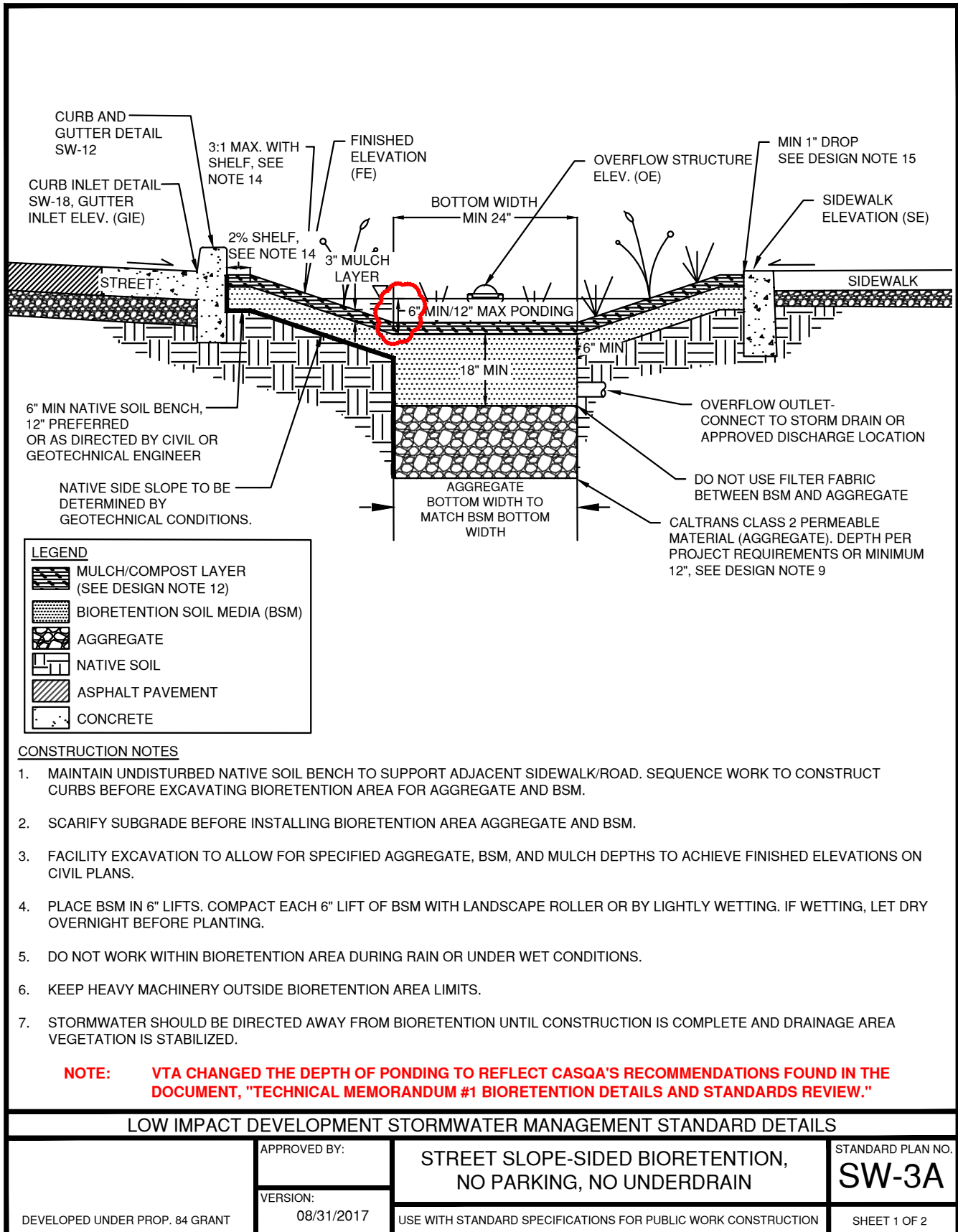



DESIGN NOTES

1. BIORETENTION FACILITY DESIGN SHOULD OPTIMIZE THE FLAT BOTTOM DIMENSIONS (I.E., WIDTH, LENGTH) TO MAXIMIZE THE FUNCTIONAL AREA OF THE FACILITY.
2. CAPTURE AND CONVEY OVERFLOW TO STORM DRAIN SYSTEM (DETAIL SW-22, SW-23). ALTERNATIVELY, CONVEY OVERFLOW TO APPROVED DISCHARGE LOCATION THROUGH OTHER OVERLAND METHODS (IE. CURB CUTS, SIDEWALK UNDERDRAIN, WEIR, ETC.).
3. PROVIDE SPOT ELEVATIONS AT INLETS AND OVERFLOW STRUCTURES ON CIVIL PLANS (FE, OE, GIE, SIE), PER DETAIL SW-18.
4. DUE TO SITE VARIABILITY, TO ENSURE THE LONG-TERM STRUCTURAL STABILITY OF THE BIORETENTION FACILITY AND ANY ADJACENT INFRASTRUCTURE CONSULT WITH A GEOTECHNICAL ENGINEER.
5. A VERTICAL LINER MAY BE USED FOR BIORETENTION FACILITIES TO PREVENT LATERAL FLOW AND TO SEPARATE THE NATIVE SOIL FROM THE BSM AND THE AGGREGATE, HOWEVER A HORIZONTAL LINER SHALL NOT BE USED.
6. DO NOT USE FILTER FABRIC BETWEEN BSM AND AGGREGATE.
7. PROVIDE A CLEAN-OUT/OBSERVATION PORT IN EACH FACILITY, PER BIORETENTION TECHNICAL SPECIFICATIONS.
8. ON LONGITUDINAL SLOPE, USE CHECK DAMS (DETAILS SW-20, SW-21)
9. USE AND DEPTH OF AGGREGATE DETERMINED BY FACILITY SIZING. IF CALTRANS CLASS 2 PERMEABLE IS NOT AVAILABLE, SUBSTITUTE CLASS 3 PERMEABLE WITH AN OVERLYING 3" DEEP CHOKING LAYER OF EITHER CALTRANS COURSE AGGREGATE 1/2" (NO. 4) OR 3/4" X (NO. 4) OPEN-GRADED AGGREGATE.
10. BIORETENTION SOIL MEDIA (BSM) SPECIFICATION PER BIORETENTION TECHNICAL SPECIFICATIONS.
11. PLANT SELECTION PER BIORETENTION TECHNICAL SPECIFICATIONS.
12. MULCH PER BIORETENTION TECHNICAL SPECIFICATIONS.
13. LOCATE ENERGY DISSIPATION AS SPECIFIED IN INLET DETAILS.
14. NATIVE SIDE SLOPE 4:1 (H:V) PREFERRED, 3:1 WITH SHELF. 6" MINIMUM SHELF WITH 2% SLOPE TOWARDS FACILITY ADJACENT TO PEDESTRIAN USE OR CURB UNLESS 4:1 SLOPE PROVIDED.
15. INCLUDE AT LEAST 1" DROP FROM CURB ABOVE MULCH LAYER.
16. AVOID DECORATIVE USE OF COBBLE THAT CAN INTERFERE WITH WITH INFILTRATION.

LOW IMPACT DEVELOPMENT STORMWATER MANAGEMENT STANDARD DETAILS

|   |                                   |   |  |
|---|-----------------------------------|---|--|
|   <p>DEVELOPED UNDER PROP. 84 GRANT</p> | <p>APPROVED BY:</p>               | <p>STREET SLOPE-SIDED BIORETENTION, NO PARKING, NO UNDERDRAIN</p> | <p>STANDARD PLAN NO.</p> <p><b>SW-3A</b></p>                         |
|   | <p>VERSION:</p> <p>08/31/2017</p> |   | <p>USE WITH STANDARD SPECIFICATIONS FOR PUBLIC WORK CONSTRUCTION</p> |

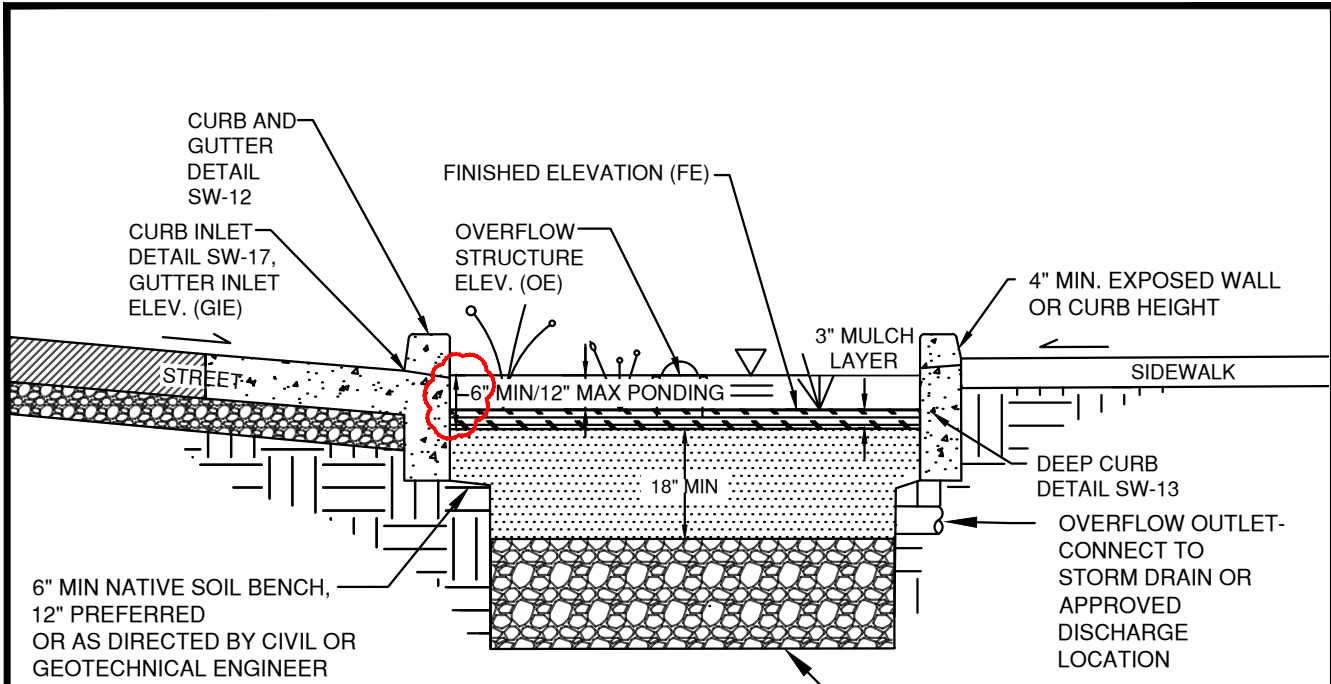

| LEGEND |  |
|--------|--|
|        | MULCH/COMPOST LAYER (SEE DESIGN NOTE 12) |
|        | BIORETENTION SOIL MEDIA (BSM)            |
|        | AGGREGATE                                |
|        | NATIVE SOIL                              |
|        | ASPHALT PAVEMENT                         |
|        | CONCRETE                                 |

**CONSTRUCTION NOTES**

1. MAINTAIN UNDISTURBED NATIVE SOIL BENCH TO SUPPORT ADJACENT SIDEWALK/ROAD. SEQUENCE WORK TO CONSTRUCT CURBS BEFORE EXCAVATING BIORETENTION AREA FOR AGGREGATE AND BSM.
2. SCARIFY SUBGRADE BEFORE INSTALLING BIORETENTION AREA AGGREGATE AND BSM.
3. FACILITY EXCAVATION TO ALLOW FOR SPECIFIED AGGREGATE, BSM, AND MULCH DEPTHS TO ACHIEVE FINISHED ELEVATIONS ON CIVIL PLANS.
4. COMPACT EACH 6" LIFT OF BSM WITH LANDSCAPE ROLLER OR BY LIGHTLY WETTING. IF WETTING, LET DRY OVERNIGHT BEFORE PLANTING.
5. DO NOT WORK WITHIN BIORETENTION AREA DURING RAIN OR UNDER WET CONDITIONS.
6. KEEP HEAVY MACHINERY OUTSIDE BIORETENTION AREA LIMITS.
7. STORMWATER SHOULD BE DIRECTED AWAY FROM BIORETENTION UNTIL CONSTRUCTION IS COMPLETE AND DRAINAGE AREA VEGETATION IS STABILIZED.

**NOTE: VTA CHANGED THE DEPTH OF PONDING TO REFLECT CASQA'S RECOMMENDATIONS FOUND IN THE DOCUMENT, "TECHNICAL MEMORANDUM #1 BIORETENTION DETAILS AND STANDARDS REVIEW."**

| LOW IMPACT DEVELOPMENT STORMWATER MANAGEMENT STANDARD DETAILS |                        |  |                   |
|---|------------------------|--|-------------------|
| DEVELOPED UNDER PROP. 84 GRANT                                | APPROVED BY:           | STREET BIORETENTION PLANTER BOX, NO PARKING, NO UNDERDRAIN | STANDARD PLAN NO. |
|   | VERSION:<br>08/31/2017 |  | SW-4A             |
| USE WITH STANDARD SPECIFICATIONS FOR PUBLIC WORK CONSTRUCTION |                        | SHEET 1 OF 2   |                   |





DESIGN NOTES

1. BIORETENTION FACILITY DESIGN SHOULD OPTIMIZE THE FLAT BOTTOM DIMENSIONS (I.E., WIDTH, LENGTH) TO MAXIMIZE THE FUNCTIONAL AREA OF THE FACILITY.
2. CAPTURE AND CONVEY OVERFLOW TO STORM DRAIN SYSTEM (DETAIL SW-22, SW-23). ALTERNATIVELY, CONVEY OVERFLOW TO APPROVED DISCHARGE LOCATION THROUGH OTHER OVERLAND METHODS (IE. CURB CUTS, SIDEWALK UNDERDRAIN, WEIR, ETC.).
3. PROVIDE SPOT ELEVATIONS AT INLETS AND OVERFLOW STRUCTURES ON CIVIL PLANS (FE, OE, GIE, SIE), PER DETAIL SW-18.
4. DUE TO SITE VARIABILITY, TO ENSURE THE LONG-TERM STRUCTURAL STABILITY OF THE BIORETENTION FACILITY AND ANY ADJACENT INFRASTRUCTURE CONSULT WITH A GEOTECHNICAL ENGINEER.
5. A VERTICAL LINER MAY BE USED FOR BIORETENTION FACILITIES TO PREVENT LATERAL FLOW AND TO SEPARATE THE NATIVE SOIL FROM THE BSM AND THE AGGREGATE, HOWEVER A HORIZONTAL LINER SHALL NOT BE USED.
6. DO NOT USE FILTER FABRIC BETWEEN BSM AND AGGREGATE.
7. PROVIDE CAPPED, THREADED PVC CLEANOUT FOR UNDERDRAIN, 4" MIN. DIA. WITH SWEEP BEND.
8. PROVIDE A CLEAN-OUT/OBSERVATION PORT IN EACH FACILITY, PER BIORETENTION TECHNICAL SPECIFICATIONS.
9. ON LONGITUDINAL SLOPE, USE CHECK DAMS (DETAILS SW-20, SW-21)
10. USE AND DEPTH OF AGGREGATE DETERMINED BY FACILITY SIZING. IF CALTRANS CLASS 2 PERMEABLE IS NOT AVAILABLE, SUBSTITUTE CLASS 3 PERMEABLE WITH AN OVERLYING 3" DEEP CHOKING LAYER OF EITHER CALTRANS COURSE AGGREGATE 1/2" (NO. 4) OR 3/4" X (NO. 4) OPEN-GRADED AGGREGATE.
11. BIORETENTION SOIL MEDIA (BSM) SPECIFICATION PER BIORETENTION TECHNICAL SPECIFICATIONS.
12. PLANT SELECTION PER BIORETENTION TECHNICAL SPECIFICATIONS.
13. MULCH PER BIORETENTION TECHNICAL SPECIFICATIONS.
14. LOCATE ENERGY DISSIPATION AS SPECIFIED IN INLET DETAILS.
15. AVOID DECORATIVE USE OF COBBLE THAT CAN INTERFERE WITH WITH INFILTRATION.

LOW IMPACT DEVELOPMENT STORMWATER MANAGEMENT STANDARD DETAILS

|   |                        |   |   |
|---|------------------------|---|---|
|  <br>DEVELOPED UNDER PROP. 84 GRANT | APPROVED BY:           | STREET BIORETENTION PLANTER BOX, NO<br>PARKING, WITH UNDERDRAIN | STANDARD PLAN NO.   |
|   | VERSION:<br>08/31/2017 |   | USE WITH STANDARD SPECIFICATIONS FOR PUBLIC WORK CONSTRUCTION |

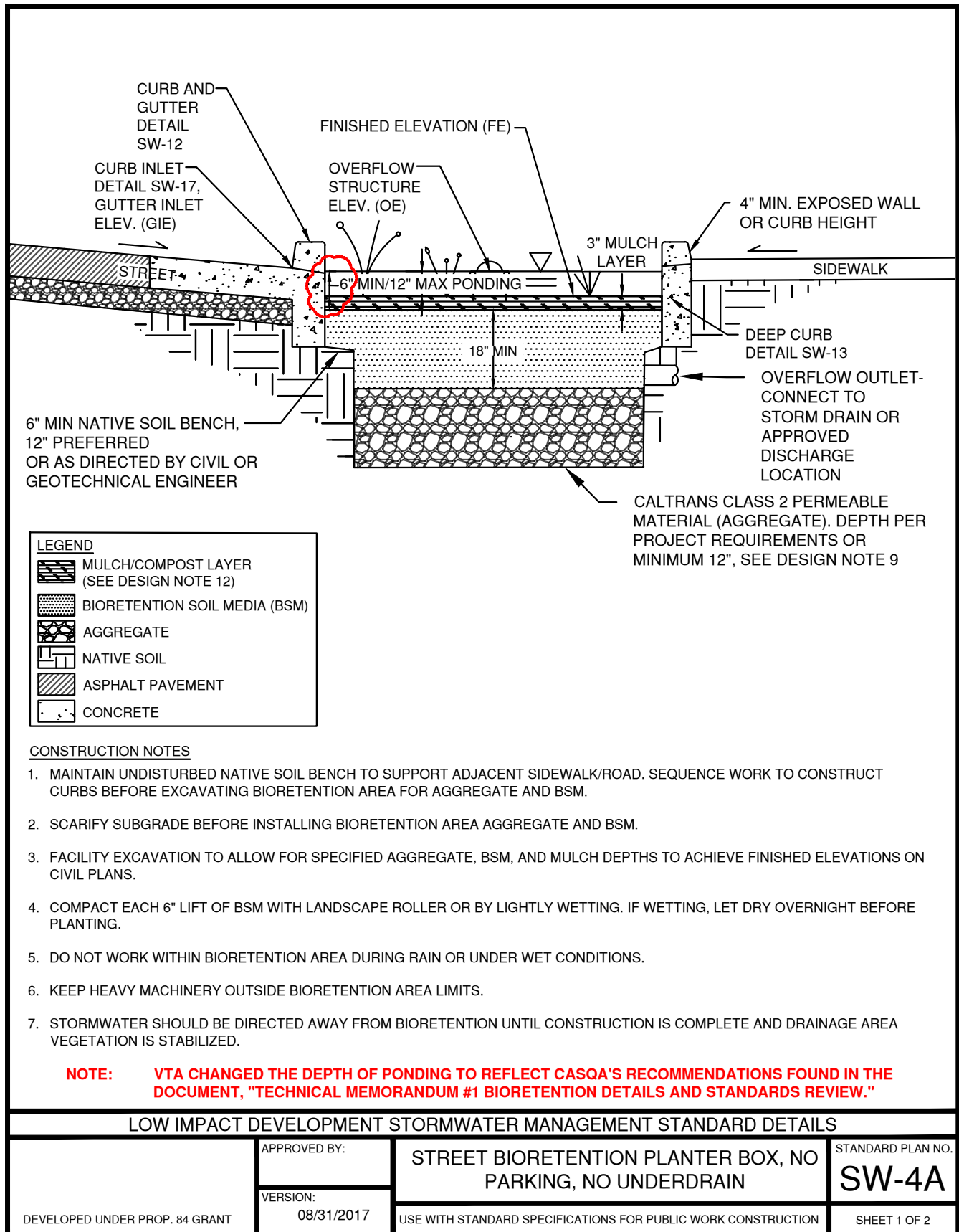



**DESIGN NOTES**

1. BIORETENTION FACILITY DESIGN SHOULD OPTIMIZE THE FLAT BOTTOM DIMENSIONS (I.E., WIDTH, LENGTH) TO MAXIMIZE THE FUNCTIONAL AREA OF THE FACILITY.
2. CAPTURE AND CONVEY OVERFLOW TO STORM DRAIN SYSTEM (DETAIL SW-22, SW-23). ALTERNATIVELY, CONVEY OVERFLOW TO APPROVED DISCHARGE LOCATION THROUGH OTHER OVERLAND METHODS (IE. CURB CUTS, SIDEWALK UNDERDRAIN, WEIR, ETC.).
3. PROVIDE SPOT ELEVATIONS AT INLETS AND OVERFLOW STRUCTURES ON CIVIL PLANS (FE, OE, GIE, SIE), PER DETAIL SW-18.
4. DUE TO SITE VARIABILITY, TO ENSURE THE LONG-TERM STRUCTURAL STABILITY OF THE BIORETENTION FACILITY AND ANY ADJACENT INFRASTRUCTURE CONSULT WITH A GEOTECHNICAL ENGINEER.
5. A VERTICAL LINER MAY BE USED FOR BIORETENTION FACILITIES TO PREVENT LATERAL FLOW AND TO SEPARATE THE NATIVE SOIL FROM THE BSM AND THE AGGREGATE, HOWEVER A HORIZONTAL LINER SHALL NOT BE USED.
6. DO NOT USE FILTER FABRIC BETWEEN BSM AND AGGREGATE.
7. PROVIDE A CLEAN-OUT/OBSERVATION PORT IN EACH FACILITY, PER BIORETENTION TECHNICAL SPECIFICATIONS.
8. ON LONGITUDINAL SLOPE, USE CHECK DAMS (DETAILS SW-20, SW-21)
9. USE AND DEPTH OF AGGREGATE DETERMINED BY FACILITY SIZING. IF CALTRANS CLASS 2 PERMEABLE IS NOT AVAILABLE, SUBSTITUTE CLASS 3 PERMEABLE WITH AN OVERLYING 3" DEEP CHOKING LAYER OF EITHER CALTRANS COURSE AGGREGATE 1/2" (NO. 4) OR 3/4" X (NO. 4) OPEN-GRADED AGGREGATE.
10. BIORETENTION SOIL MEDIA (BSM) SPECIFICATION PER BIORETENTION TECHNICAL SPECIFICATIONS.
11. PLANT SELECTION PER BIORETENTION TECHNICAL SPECIFICATIONS.
12. MULCH PER BIORETENTION TECHNICAL SPECIFICATIONS.
13. LOCATE ENERGY DISSIPATION AS SPECIFIED IN INLET DETAILS.
14. AVOID DECORATIVE USE OF COBBLE THAT CAN INTERFERE WITH WITH INFILTRATION.

**LOW IMPACT DEVELOPMENT STORMWATER MANAGEMENT STANDARD DETAILS**

|   |                        |   |   |
|---|------------------------|---|---|
|  <br>DEVELOPED UNDER PROP. 84 GRANT | APPROVED BY:           | STREET BIORETENTION PLANTER BOX, NO<br>PARKING, NO UNDERDRAIN | STANDARD PLAN NO.<br><b>SW-4A</b>                             |
|   | VERSION:<br>08/31/2017 |   | USE WITH STANDARD SPECIFICATIONS FOR PUBLIC WORK CONSTRUCTION |

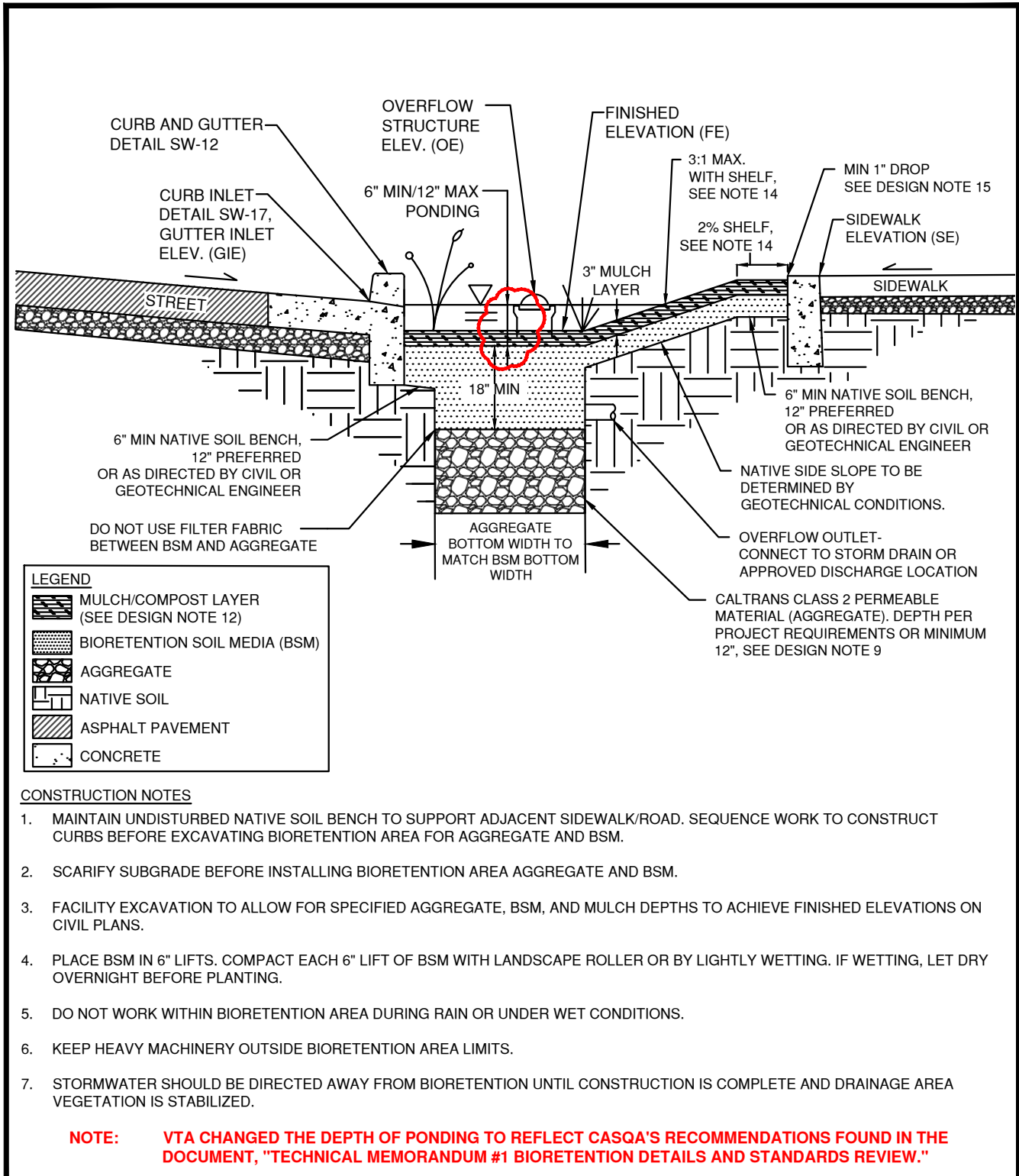

LOW IMPACT DEVELOPMENT STORMWATER MANAGEMENT STANDARD DETAILS

|   |                        |   |                   |
|---|------------------------|---|-------------------|
| DEVELOPED UNDER PROP. 84 GRANT                                | APPROVED BY:           | STREET BIORETENTION BULB OUT, NO PARKING, NO UNDERDRAIN, SINGLE SLOPE | STANDARD PLAN NO. |
|   | VERSION:<br>08/31/2017 |   | SW-5              |
| USE WITH STANDARD SPECIFICATIONS FOR PUBLIC WORK CONSTRUCTION |                        | SHEET 1 OF 2  |                   |



DESIGN NOTES

1. BIORETENTION FACILITY DESIGN SHOULD OPTIMIZE THE FLAT BOTTOM DIMENSIONS (I.E., WIDTH, LENGTH) TO MAXIMIZE THE FUNCTIONAL AREA OF THE FACILITY.
2. CAPTURE AND CONVEY OVERFLOW TO STORM DRAIN SYSTEM (DETAIL SW-22, SW-23). ALTERNATIVELY, CONVEY OVERFLOW TO APPROVED DISCHARGE LOCATION THROUGH OTHER OVERLAND METHODS (IE. CURB CUTS, SIDEWALK UNDERDRAIN, WEIR, ETC.).
3. PROVIDE SPOT ELEVATIONS AT INLETS AND OVERFLOW STRUCTURES ON CIVIL PLANS (FE, OE, GIE, SIE), PER DETAIL SW-18.
4. DUE TO SITE VARIABILITY, TO ENSURE THE LONG-TERM STRUCTURAL STABILITY OF THE BIORETENTION FACILITY AND ANY ADJACENT INFRASTRUCTURE CONSULT WITH A GEOTECHNICAL ENGINEER.
5. A VERTICAL LINER MAY BE USED FOR BIORETENTION FACILITIES TO PREVENT LATERAL FLOW AND TO SEPARATE THE NATIVE SOIL FROM THE BSM AND THE AGGREGATE, HOWEVER A HORIZONTAL LINER SHALL NOT BE USED.
6. DO NOT USE FILTER FABRIC BETWEEN BSM AND AGGREGATE.
7. PROVIDE A CLEAN-OUT/OBSERVATION PORT IN EACH FACILITY, PER BIORETENTION TECHNICAL SPECIFICATIONS.
8. ON LONGITUDINAL SLOPE, USE CHECK DAMS (DETAILS SW-20, SW-21)
9. USE AND DEPTH OF AGGREGATE DETERMINED BY FACILITY SIZING. IF CALTRANS CLASS 2 PERMEABLE IS NOT AVAILABLE, SUBSTITUTE CLASS 3 PERMEABLE WITH AN OVERLYING 3" DEEP CHOKING LAYER OF EITHER CALTRANS COURSE AGGREGATE 1/2" (NO. 4) OR 3/4" X (NO. 4) OPEN-GRADED AGGREGATE.
10. BIORETENTION SOIL MEDIA (BSM) SPECIFICATION PER BIORETENTION TECHNICAL SPECIFICATIONS.
11. PLANT SELECTION PER BIORETENTION TECHNICAL SPECIFICATIONS.
12. MULCH PER BIORETENTION TECHNICAL SPECIFICATIONS.
13. LOCATE ENERGY DISSIPATION AS SPECIFIED IN INLET DETAILS.
14. NATIVE SIDE SLOPE 4:1 (H:V) PREFERRED, 3:1 WITH SHELF. 6" MINIMUM SHELF WITH 2% SLOPE TOWARDS FACILITY ADJACENT TO PEDESTRIAN USE OR CURB UNLESS 4:1 SLOPE PROVIDED.
15. INCLUDE AT LEAST 1" DROP FROM CURB ABOVE MULCH LAYER.
16. AVOID DECORATIVE USE OF COBBLE THAT CAN INTERFERE WITH WITH INFILTRATION.

LOW IMPACT DEVELOPMENT STORMWATER MANAGEMENT STANDARD DETAILS

|   |                        |   |  |
|---|------------------------|---|--|
|   <p>DEVELOPED UNDER PROP. 84 GRANT</p> | APPROVED BY:           | <p>STREET BIORETENTION BULB OUT, NO PARKING, NO UNDERDRAIN, SINGLE SLOPE</p> <p>USE WITH STANDARD SPECIFICATIONS FOR PUBLIC WORK CONSTRUCTION</p> | STANDARD PLAN NO.                      |
|   | VERSION:<br>08/31/2017 |   | <p><b>SW-5</b></p> <p>SHEET 2 OF 2</p> |

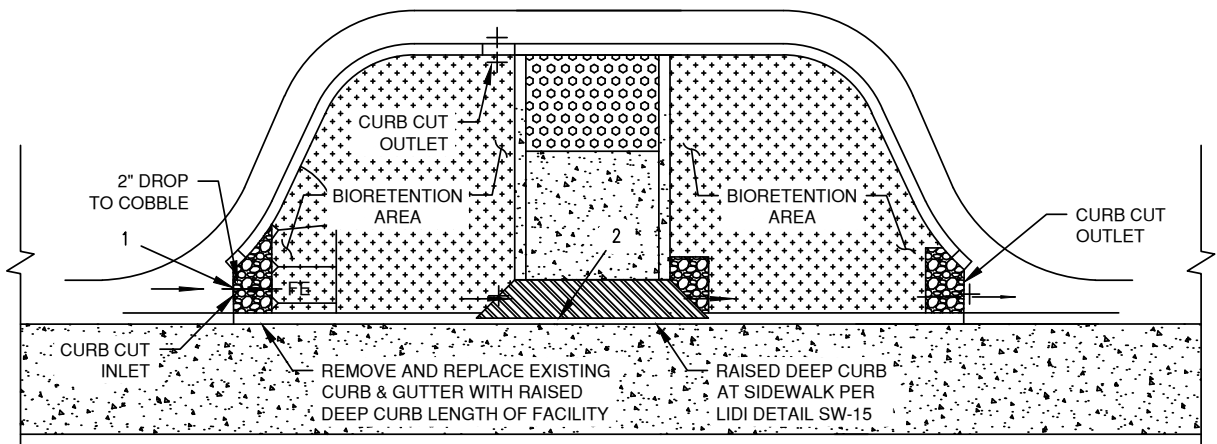
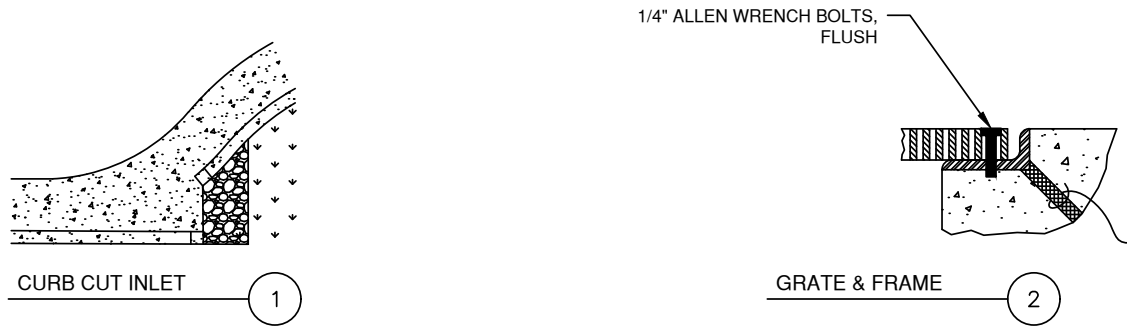

**CONSTRUCTION NOTES:**

1. INSTALL GRAVEL BAGS AT CURB CUTS TO BLOCK FLOW FROM ENTERING BIORETENTION AREA. CITY TO REMOVE GRAVEL BAGS AT A TIME FOLLOWING CONSTRUCTION COMPLETION.

**DESIGN NOTE:**

1. THIS STANDARD DETAIL ASSUMES GRADUAL LONGITUDINAL AND CROSS SLOPES OF THE ROADWAY. STEEPER SLOPES IN EITHER DIRECTION WILL IMPACT CONVEYANCE AND ELEVATION DIFFERENCES BETWEEN THE FACILITY AND ADJACENT ROADWAY, CURB, AND SIDEWALK SURFACES. RETROFIT PROJECTS WILL FACE GREATER CONSTRAINTS THAN NEW CONSTRUCTION. SITE SPECIFIC DESIGN IS CRITICAL TO AVOID GRADE CONFLICTS AND MAXIMIZING PONDING AREA. GRADING PLANS THAT PROVIDE SPOT ELEVATIONS ACROSS THE ENTIRE FACILITY AND ALONG ADJACENT SURFACES ARE NECESSARY.

**LOW IMPACT DEVELOPMENT STORMWATER MANAGEMENT STANDARD DETAILS**

|   |                        |   |   |
|---|------------------------|---|---|
|  <br>DEVELOPED UNDER PROP. 84 GRANT | APPROVED BY:           | <b>STREET BIORETENTION BULB OUT, MID<br/>BLOCK CROSSING</b> | STANDARD PLAN NO.   |
|   | VERSION:<br>08/31/2017 |   | USE WITH STANDARD SPECIFICATIONS FOR PUBLIC WORK CONSTRUCTION |

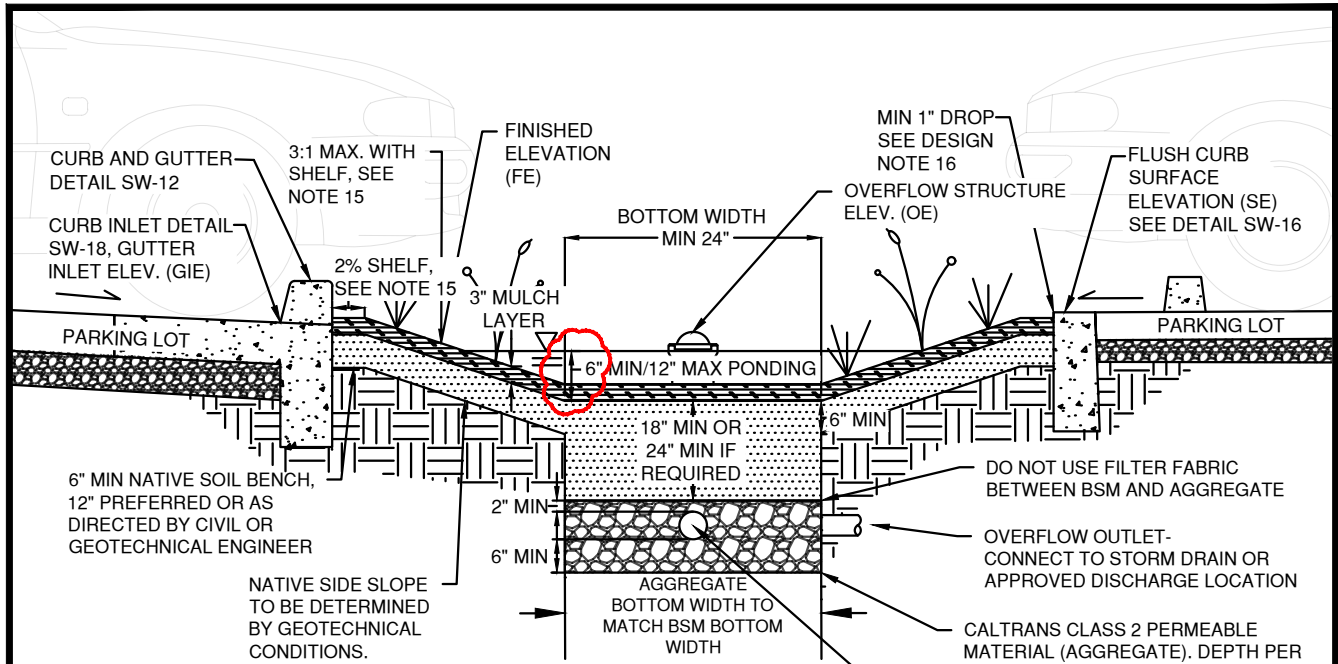

| LEGEND |  |
|--------|--|
|        | MULCH/COMPOST LAYER (SEE DESIGN NOTE 12) |
|        | BIORETENTION SOIL MEDIA (BSM)            |
|        | AGGREGATE                                |
|        | NATIVE SOIL                              |
|        | ASPHALT PAVEMENT                         |
|        | CONCRETE                                 |

**CONSTRUCTION NOTES**

1. MAINTAIN UNDISTURBED NATIVE SOIL BENCH TO SUPPORT ADJACENT SIDEWALK/ROAD. SEQUENCE WORK TO CONSTRUCT CURBS BEFORE EXCAVATING BIORETENTION AREA FOR AGGREGATE AND BSM.
2. SCARIFY SUBGRADE BEFORE INSTALLING BIORETENTION AREA AGGREGATE AND BSM.
3. FACILITY EXCAVATION TO ALLOW FOR SPECIFIED AGGREGATE, BSM, AND MULCH DEPTHS TO ACHIEVE FINISHED ELEVATIONS ON CIVIL PLANS.
4. INSTALL UNDERDRAIN WITH HOLES FACING DOWN. TOP OF UNDERDRAIN 6" BELOW TOP OF AGGREGATE LAYER. UNDERDRAIN SLOPE MAY BE FLAT.
5. PLACE BSM IN 6" LIFTS. COMPACT EACH 6" LIFT OF BSM WITH LANDSCAPE ROLLER OR BY LIGHTLY WETTING. IF WETTING, LET DRY OVERNIGHT BEFORE PLANTING.
6. DO NOT WORK WITHIN BIORETENTION AREA DURING RAIN OR UNDER WET CONDITIONS.
7. KEEP HEAVY MACHINERY OUTSIDE BIORETENTION AREA LIMITS.
8. STORMWATER SHOULD BE DIRECTED AWAY FROM BIORETENTION UNTIL CONSTRUCTION IS COMPLETE AND DRAINAGE AREA VEGETATION IS STABILIZED.

**NOTE:** VTA CHANGED THE DEPTH OF PONDING TO REFLECT CASQA'S RECOMMENDATIONS FOUND IN THE DOCUMENT, "TECHNICAL MEMORANDUM #1 BIORETENTION DETAILS AND STANDARDS REVIEW."

LOW IMPACT DEVELOPMENT STORMWATER MANAGEMENT STANDARD DETAILS

|   |                        |  |                   |
|---|------------------------|--|-------------------|
| DEVELOPED UNDER PROP. 84 GRANT                                | APPROVED BY:           | PARKING LOT SLOPE-SIDED BIORETENTION,<br>WITH UNDERDRAIN | STANDARD PLAN NO. |
|   | VERSION:<br>08/31/2017 |  | SW-6              |
| USE WITH STANDARD SPECIFICATIONS FOR PUBLIC WORK CONSTRUCTION |                        | SHEET 1 OF 2   |                   |



DESIGN NOTES

1. BIORETENTION FACILITY DESIGN SHOULD OPTIMIZE THE FLAT BOTTOM DIMENSIONS (I.E., WIDTH, LENGTH) TO MAXIMIZE THE FUNCTIONAL AREA OF THE FACILITY.
2. CAPTURE AND CONVEY OVERFLOW TO STORM DRAIN SYSTEM (DETAIL SW-22, SW-23). ALTERNATIVELY, CONVEY OVERFLOW TO APPROVED DISCHARGE LOCATION THROUGH OTHER OVERLAND METHODS (IE. CURB CUTS, SIDEWALK UNDERDRAIN, WEIR, ETC.).
3. PROVIDE SPOT ELEVATIONS AT INLETS AND OVERFLOW STRUCTURES ON CIVIL PLANS (FE, OE, GIE, SIE), PER DETAIL SW-18.
4. DUE TO SITE VARIABILITY, TO ENSURE THE LONG-TERM STRUCTURAL STABILITY OF THE BIORETENTION FACILITY AND ANY ADJACENT INFRASTRUCTURE CONSULT WITH A GEOTECHNICAL ENGINEER.
5. A VERTICAL LINER MAY BE USED FOR BIORETENTION FACILITIES TO PREVENT LATERAL FLOW AND TO SEPARATE THE NATIVE SOIL FROM THE BSM AND THE AGGREGATE, HOWEVER A HORIZONTAL LINER SHALL NOT BE USED.
6. DO NOT USE FILTER FABRIC BETWEEN BSM AND AGGREGATE.
7. PROVIDE CAPPED, THREADED PVC CLEANOUT FOR UNDERDRAIN, 4" MIN. DIA. WITH SWEEP BEND.
8. PROVIDE A CLEAN-OUT/OBSERVATION PORT IN EACH FACILITY, PER BIORETENTION TECHNICAL SPECIFICATIONS.
9. ON LONGITUDINAL SLOPE, USE CHECK DAMS (DETAILS SW-20, SW-21)
10. DEPTH OF AGGREGATE DETERMINED BY FACILITY SIZING. IF CALTRANS CLASS 2 PERMEABLE IS NOT AVAILABLE, SUBSTITUTE CLASS 3 PERMEABLE WITH AN OVERLYING 3" DEEP CHOKING LAYER OF EITHER CALTRANS COURSE AGGREGATE 1/2" (NO. 4) OR 3/4" X (NO.4) OPEN-GRADED AGGREGATE.
11. BIORETENTION SOIL MEDIA (BSM) SPECIFICATION PER BIORETENTION TECHNICAL SPECIFICATIONS.
12. PLANT SELECTION PER BIORETENTION TECHNICAL SPECIFICATIONS.
13. MULCH PER BIORETENTION TECHNICAL SPECIFICATIONS.
14. LOCATE ENERGY DISSIPATION AS SPECIFIED IN INLET DETAILS.
15. NATIVE SIDE SLOPE 4:1 (H:V) PREFERRED, 3:1 WITH BENCH. 6" MINIMUM SHELF WITH 2% SLOPE TOWARDS FACILITY ADJACENT TO PEDESTRIAN USE OR CURB UNLESS 4:1 SLOPE PROVIDED.
16. INCLUDE AT LEAST 1" DROP FROM CURB ABOVE MULCH LAYER.
17. AVOID DECORATIVE USE OF COBBLE THAT CAN INTERFERE WITH WITH INFILTRATION.

LOW IMPACT DEVELOPMENT STORMWATER MANAGEMENT STANDARD DETAILS

|   |                        |  |   |
|---|------------------------|--|---|
|  <br>DEVELOPED UNDER PROP. 84 GRANT | APPROVED BY:           | PARKING LOT SLOPE-SIDED<br>BIORETENTION, WITH UNDERDRAIN | STANDARD PLAN NO.   |
|   | VERSION:<br>08/31/2017 |  | SW-6<br><br>USE WITH STANDARD SPECIFICATIONS FOR PUBLIC WORK CONSTRUCTION |



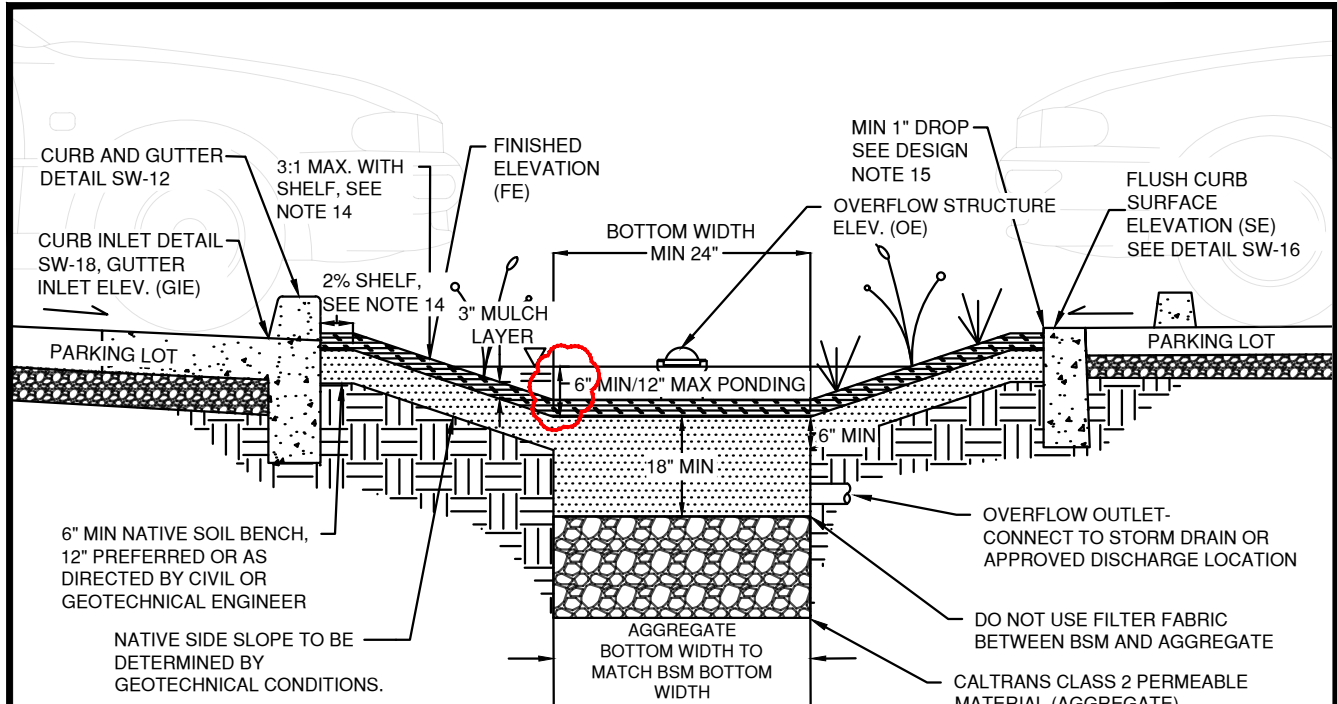

| LEGEND |   |
|--------|---|
|        | MULCH/COMPOST LAYER<br>(SEE DESIGN NOTE 12) |
|        | BIORETENTION SOIL MEDIA (BSM)               |
|        | AGGREGATE                                   |
|        | NATIVE SOIL                                 |
|        | ASPHALT PAVEMENT                            |
|        | CONCRETE                                    |

**CONSTRUCTION NOTES**

1. MAINTAIN UNDISTURBED NATIVE SOIL BENCH TO SUPPORT ADJACENT SIDEWALK/ROAD. SEQUENCE WORK TO CONSTRUCT CURBS BEFORE EXCAVATING BIORETENTION AREA FOR AGGREGATE AND BSM.
2. SCARIFY SUBGRADE BEFORE INSTALLING BIORETENTION AREA AGGREGATE AND BSM.
3. FACILITY EXCAVATION TO ALLOW FOR SPECIFIED AGGREGATE, BSM, AND MULCH DEPTHS TO ACHIEVE FINISHED ELEVATIONS ON CIVIL PLANS.
4. PLACE BSM IN 6" LIFTS. COMPACT EACH 6" LIFT OF BSM WITH LANDSCAPE ROLLER OR BY LIGHTLY WETTING. IF WETTING, LET DRY OVERNIGHT BEFORE PLANTING.
5. DO NOT WORK WITHIN BIORETENTION AREA DURING RAIN OR UNDER WET CONDITIONS.
6. KEEP HEAVY MACHINERY OUTSIDE BIORETENTION AREA LIMITS.
7. STORMWATER SHOULD BE DIRECTED AWAY FROM BIORETENTION UNTIL CONSTRUCTION IS COMPLETE AND DRAINAGE AREA VEGETATION IS STABILIZED.

**NOTE:** VTA CHANGED THE DEPTH OF PONDING TO REFLECT CASQA'S RECOMMENDATIONS FOUND IN THE DOCUMENT, "TECHNICAL MEMORANDUM #1 BIORETENTION DETAILS AND STANDARDS REVIEW."

**LOW IMPACT DEVELOPMENT STORMWATER MANAGEMENT STANDARD DETAILS**



|   |                        |  |                                   |
|---|------------------------|--|-----------------------------------|
| DEVELOPED UNDER PROP. 84 GRANT                                | APPROVED BY:           | PARKING LOT SLOPE-SIDED<br>BIORETENTION, NO UNDERDRAIN | STANDARD PLAN NO.<br><b>SW-6A</b> |
|   | VERSION:<br>08/31/2017 |  | SHEET 1 OF 2                      |
| USE WITH STANDARD SPECIFICATIONS FOR PUBLIC WORK CONSTRUCTION |                        |  |                                   |



DESIGN NOTES

1. BIORETENTION FACILITY DESIGN SHOULD OPTIMIZE THE FLAT BOTTOM DIMENSIONS (I.E., WIDTH, LENGTH) TO MAXIMIZE THE FUNCTIONAL AREA OF THE FACILITY.
2. CAPTURE AND CONVEY OVERFLOW TO STORM DRAIN SYSTEM (DETAIL SW-22, SW-23). ALTERNATIVELY, CONVEY OVERFLOW TO APPROVED DISCHARGE LOCATION THROUGH OTHER OVERLAND METHODS (IE. CURB CUTS, SIDEWALK UNDERDRAIN, WEIR, ETC.).
3. PROVIDE SPOT ELEVATIONS AT INLETS AND OVERFLOW STRUCTURE ON CIVIL PLANS (FE,OE, GIE, SIE), PER DETAIL SW-18.
4. DUE TO SITE VARIABILITY, TO ENSURE THE LONG-TERM STRUCTURAL STABILITY OF THE BIORETENTION FACILITY AND ANY ADJACENT INFRASTRUCTURE CONSULT WITH A GEOTECHNICAL ENGINEER.
5. A VERTICAL LINER MAY BE USED FOR BIORETENTION FACILITIES TO PREVENT LATERAL FLOW AND TO SEPARATE THE NATIVE SOIL FROM THE BSM AND THE AGGREGATE, HOWEVER A HORIZONTAL LINER SHALL NOT BE USED.
6. DO NOT USE FILTER FABRIC BETWEEN BSM AND AGGREGATE.
7. PROVIDE A CLEAN-OUT/OBSERVATION PORT IN EACH FACILITY, PER BIORETENTION TECHNICAL SPECIFICATIONS.
8. ON LONGITUDINAL SLOPE, USE CHECK DAMS (DETAILS SW-20, SW-21)
9. USE AND DEPTH OF AGGREGATE DETERMINED BY FACILITY SIZING. IF CALTRANS CLASS 2 PERMEABLE IS NOT AVAILABLE, SUBSTITUTE CLASS 3 PERMEABLE WITH AN OVERLYING 3" DEEP CHOKING LAYER OF EITHER CALTRANS COURSE AGGREGATE 1/2" (NO. 4) OR 3/4" X (NO. 4) OPEN-GRADED AGGREGATE.
10. BIORETENTION SOIL MEDIA (BSM) SPECIFICATION PER BIORETENTION TECHNICAL SPECIFICATIONS.
11. PLANT SELECTION PER BIORETENTION TECHNICAL SPECIFICATIONS.
12. MULCH PER BIORETENTION TECHNICAL SPECIFICATIONS.
13. LOCATE ENERGY DISSIPATION AS SPECIFIED IN INLET DETAILS.
14. NATIVE SIDE SLOPE 4:1 (H:V) PREFERRED, 3:1 WITH SHELF. 6" MINIMUM SHELF WITH 2% SLOPE TOWARDS FACILITY ADJACENT TO PEDESTRIAN USE OR CURB UNLESS 4:1 SLOPE PROVIDED.
15. INCLUDE AT LEAST 1" DROP FROM CURB ABOVE MULCH LAYER.
16. AVOID DECORATIVE USE OF COBBLE THAT CAN INTERFERE WITH WITH INFILTRATION.

LOW IMPACT DEVELOPMENT STORMWATER MANAGEMENT STANDARD DETAILS

|   |                        |  |                       |
|---|------------------------|--|-----------------------|
|  <br>DEVELOPED UNDER PROP. 84 GRANT | APPROVED BY:           | PARKING LOT SLOPE-SIDED<br>BIORETENTION, NO UNDERDRAIN | STANDARD PLAN NO.     |
|   | VERSION:<br>08/31/2017 |  | SW-6A<br>SHEET 2 OF 2 |
| USE WITH STANDARD SPECIFICATIONS FOR PUBLIC WORK CONSTRUCTION   |                        |  |                       |

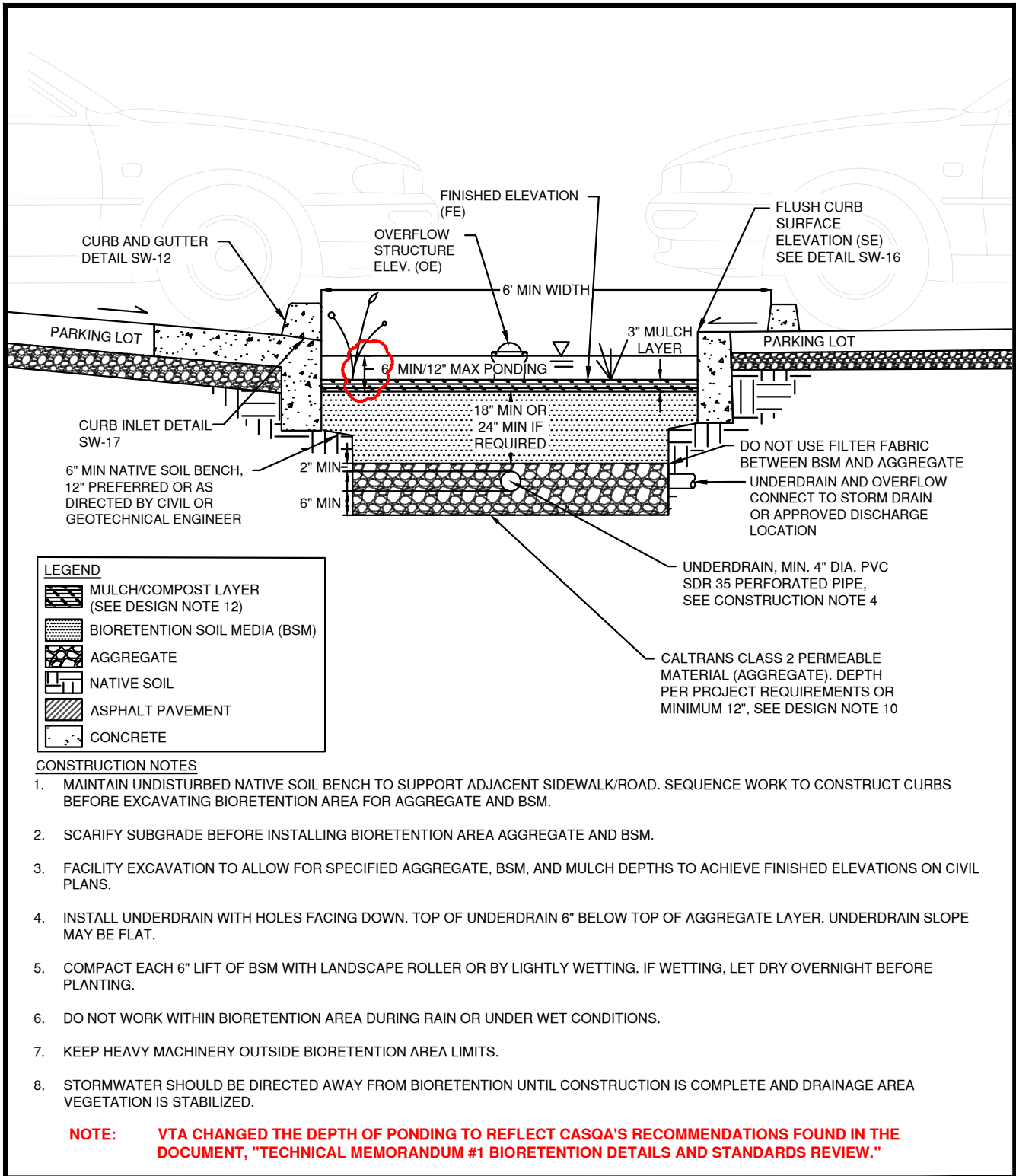

LOW IMPACT DEVELOPMENT STORMWATER MANAGEMENT STANDARD DETAILS

|   |                        |   |                   |
|---|------------------------|---|-------------------|
| DEVELOPED UNDER PROP. 84 GRANT                                | APPROVED BY:           | PARKING LOT BIORETENTION PLANTER BOX, WITH UNDERDRAIN | STANDARD PLAN NO. |
|   | VERSION:<br>08/31/2017 |   | SW-7              |
| USE WITH STANDARD SPECIFICATIONS FOR PUBLIC WORK CONSTRUCTION |                        | SHEET 1 OF 2  |                   |



DESIGN NOTES

1. BIORETENTION FACILITY DESIGN SHOULD OPTIMIZE THE FLAT BOTTOM DIMENSIONS (I.E., WIDTH, LENGTH) TO MAXIMIZE THE FUNCTIONAL AREA OF THE FACILITY.
2. CAPTURE AND CONVEY OVERFLOW TO STORM DRAIN SYSTEM (DETAIL SW-22, SW-23). ALTERNATIVELY, CONVEY OVERFLOW TO APPROVED DISCHARGE LOCATION THROUGH OTHER OVERLAND METHODS (IE. CURB CUTS, SIDEWALK UNDERDRAIN, WEIR, ETC.).
3. PROVIDE SPOT ELEVATIONS AT INLETS AND OVERFLOW STRUCTURES ON CIVIL PLANS (FE, OE, GIE, SIE), PER DETAIL SW-18.
4. DUE TO SITE VARIABILITY, TO ENSURE THE LONG-TERM STRUCTURAL STABILITY OF THE BIORETENTION FACILITY AND ANY ADJACENT INFRASTRUCTURE CONSULT WITH A GEOTECHNICAL ENGINEER.
5. A VERTICAL LINER MAY BE USED FOR BIORETENTION FACILITIES TO PREVENT LATERAL FLOW AND TO SEPARATE THE NATIVE SOIL FROM THE BSM AND THE AGGREGATE, HOWEVER A HORIZONTAL LINER SHALL NOT BE USED.
6. DO NOT USE FILTER FABRIC BETWEEN BSM AND AGGREGATE.
7. PROVIDE CAPPED, THREADED PVC CLEANOUT FOR UNDERDRAIN, 4" MIN. DIA. WITH SWEEP BEND.
8. PROVIDE A CLEAN-OUT/OBSERVATION PORT IN EACH FACILITY, PER BIORETENTION TECHNICAL SPECIFICATIONS.
9. ON LONGITUDINAL SLOPE, USE CHECK DAMS (DETAILS SW-20, SW-21)
10. USE AND DEPTH OF AGGREGATE DETERMINED BY FACILITY SIZING. IF CALTRANS CLASS 2 PERMEABLE IS NOT AVAILABLE, SUBSTITUTE CLASS 3 PERMEABLE WITH AN OVERLYING 3" DEEP CHOKING LAYER OF EITHER CALTRANS COURSE AGGREGATE 1/2" (NO. 4) OR 3/4" X (NO. 4) OPEN-GRADED AGGREGATE.
11. BIORETENTION SOIL MEDIA (BSM) SPECIFICATION PER BIORETENTION TECHNICAL SPECIFICATIONS.
12. PLANT SELECTION PER BIORETENTION TECHNICAL SPECIFICATIONS.
13. MULCH PER BIORETENTION TECHNICAL SPECIFICATIONS.
14. LOCATE ENERGY DISSIPATION AS SPECIFIED IN INLET DETAILS.
15. AVOID DECORATIVE USE OF COBBLE THAT CAN INTERFERE WITH WITH INFILTRATION.

LOW IMPACT DEVELOPMENT STORMWATER MANAGEMENT STANDARD DETAILS

|   |                        |   |                    |
|---|------------------------|---|--------------------|
|   <p>DEVELOPED UNDER PROP. 84 GRANT</p> | APPROVED BY:           | <p>PARKING LOT BIORETENTION PLANTER BOX, WITH UNDERDRAIN</p>  | STANDARD PLAN NO.  |
|   | VERSION:<br>08/31/2017 |   | <p><b>SW-7</b></p> |
|   |                        | USE WITH STANDARD SPECIFICATIONS FOR PUBLIC WORK CONSTRUCTION | SHEET 2 OF 2       |

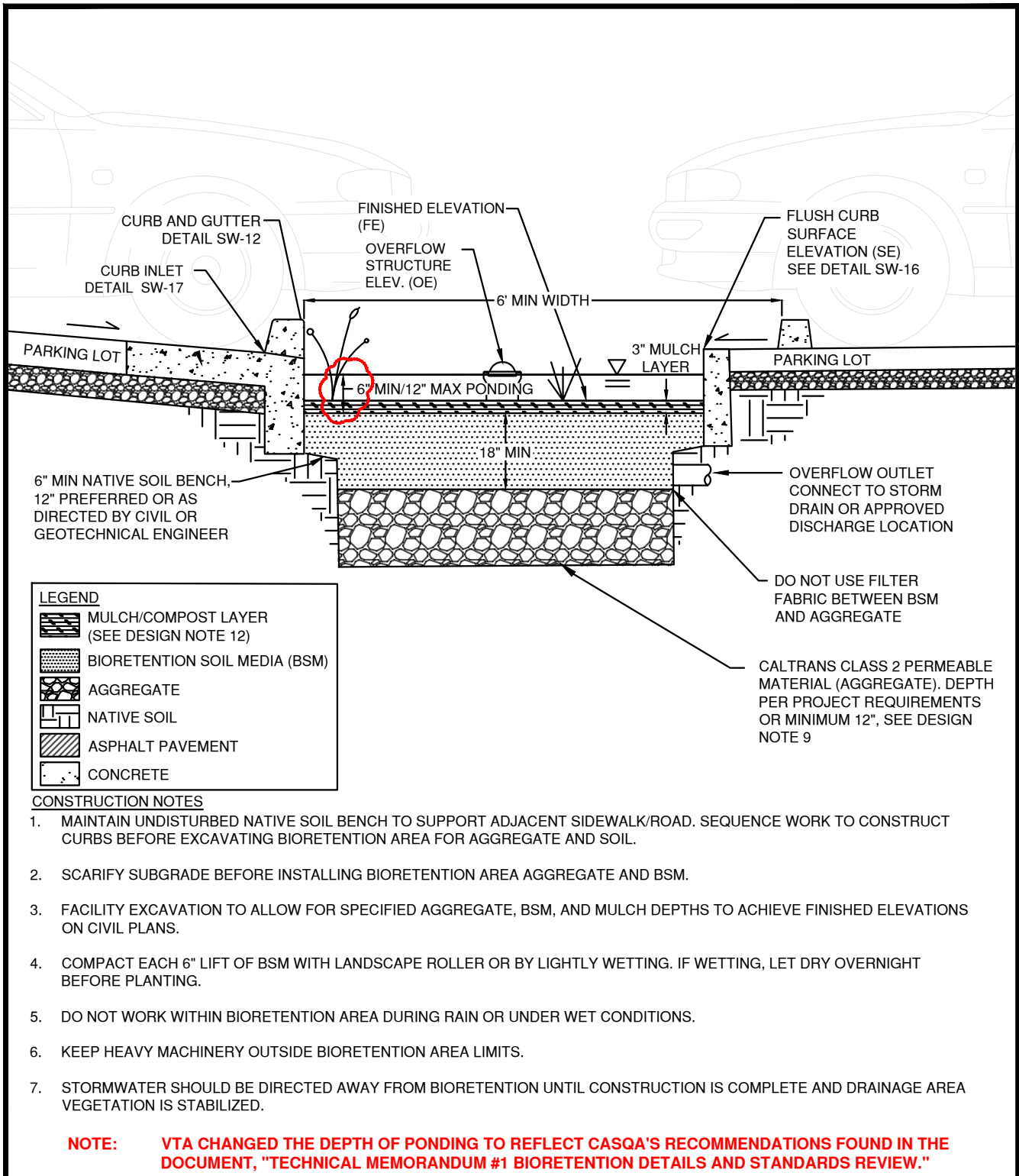

LOW IMPACT DEVELOPMENT STORMWATER MANAGEMENT STANDARD DETAILS

|   |                        |  |                   |
|---|------------------------|--|-------------------|
| DEVELOPED UNDER PROP. 84 GRANT                                | APPROVED BY:           | PARKING LOT BIORETENTION PLANTER<br>BOX, NO UNDERDRAIN | STANDARD PLAN NO. |
|   | VERSION:<br>08/31/2017 |  | SW-7A             |
| USE WITH STANDARD SPECIFICATIONS FOR PUBLIC WORK CONSTRUCTION |                        | SHEET 1 OF 2   |                   |



DESIGN NOTES

1. BIORETENTION FACILITY DESIGN SHOULD OPTIMIZE THE FLAT BOTTOM DIMENSIONS (I.E., WIDTH, LENGTH) TO MAXIMIZE THE FUNCTIONAL AREA OF THE FACILITY.
2. CAPTURE AND CONVEY OVERFLOW TO STORM DRAIN SYSTEM (DETAIL SW-22, SW-23). ALTERNATIVELY, CONVEY OVERFLOW TO APPROVED DISCHARGE LOCATION THROUGH OTHER OVERLAND METHODS (IE. CURB CUTS, SIDEWALK UNDERDRAIN, WEIR, ETC.).
3. PROVIDE SPOT ELEVATIONS AT INLETS AND OVERFLOW STRUCTURES ON CIVIL PLANS (FE, OE, GIE, SIE), PER DETAIL SW-18.
4. DUE TO SITE VARIABILITY, TO ENSURE THE LONG-TERM STRUCTURAL STABILITY OF THE BIORETENTION FACILITY AND ANY ADJACENT INFRASTRUCTURE CONSULT WITH A GEOTECHNICAL ENGINEER.
5. A VERTICAL LINER MAY BE USED FOR BIORETENTION FACILITIES TO PREVENT LATERAL FLOW AND TO SEPARATE THE NATIVE SOIL FROM THE BSM AND THE AGGREGATE, HOWEVER A HORIZONTAL LINER SHALL NOT BE USED.
6. DO NOT USE FILTER FABRIC BETWEEN BSM AND AGGREGATE.
7. PROVIDE A CLEAN-OUT/OBSERVATION PORT IN EACH FACILITY, PER BIORETENTION TECHNICAL SPECIFICATIONS.
8. ON LONGITUDINAL SLOPE, USE CHECK DAMS (DETAILS SW-20, SW-21)
9. USE AND DEPTH OF AGGREGATE DETERMINED BY FACILITY SIZING. IF CALTRANS CLASS 2 PERMEABLE IS NOT AVAILABLE, SUBSTITUTE CLASS 3 PERMEABLE WITH AN OVERLYING 3" DEEP CHOKING LAYER OF EITHER CALTRANS COURSE AGGREGATE 1/2" (NO. 4) OR 3/4" X (NO. 4) OPEN-GRADED AGGREGATE.
10. BIORETENTION SOIL MEDIA (BSM) SPECIFICATION PER BIORETENTION TECHNICAL SPECIFICATIONS.
11. PLANT SELECTION PER BIORETENTION TECHNICAL SPECIFICATIONS.
12. MULCH PER BIORETENTION TECHNICAL SPECIFICATIONS.
13. LOCATE ENERGY DISSIPATION AS SPECIFIED IN INLET DETAILS.
14. AVOID DECORATIVE USE OF COBBLE THAT CAN INTERFERE WITH WITH INFILTRATION.

LOW IMPACT DEVELOPMENT STORMWATER MANAGEMENT STANDARD DETAILS

|   |                        |  |   |
|---|------------------------|--|---|
|  <br>DEVELOPED UNDER PROP. 84 GRANT | APPROVED BY:           | PARKING LOT BIORETENTION PLANTER<br>BOX, NO UNDERDRAIN | STANDARD PLAN NO.   |
|   | VERSION:<br>08/31/2017 |  | USE WITH STANDARD SPECIFICATIONS FOR PUBLIC WORK CONSTRUCTION |

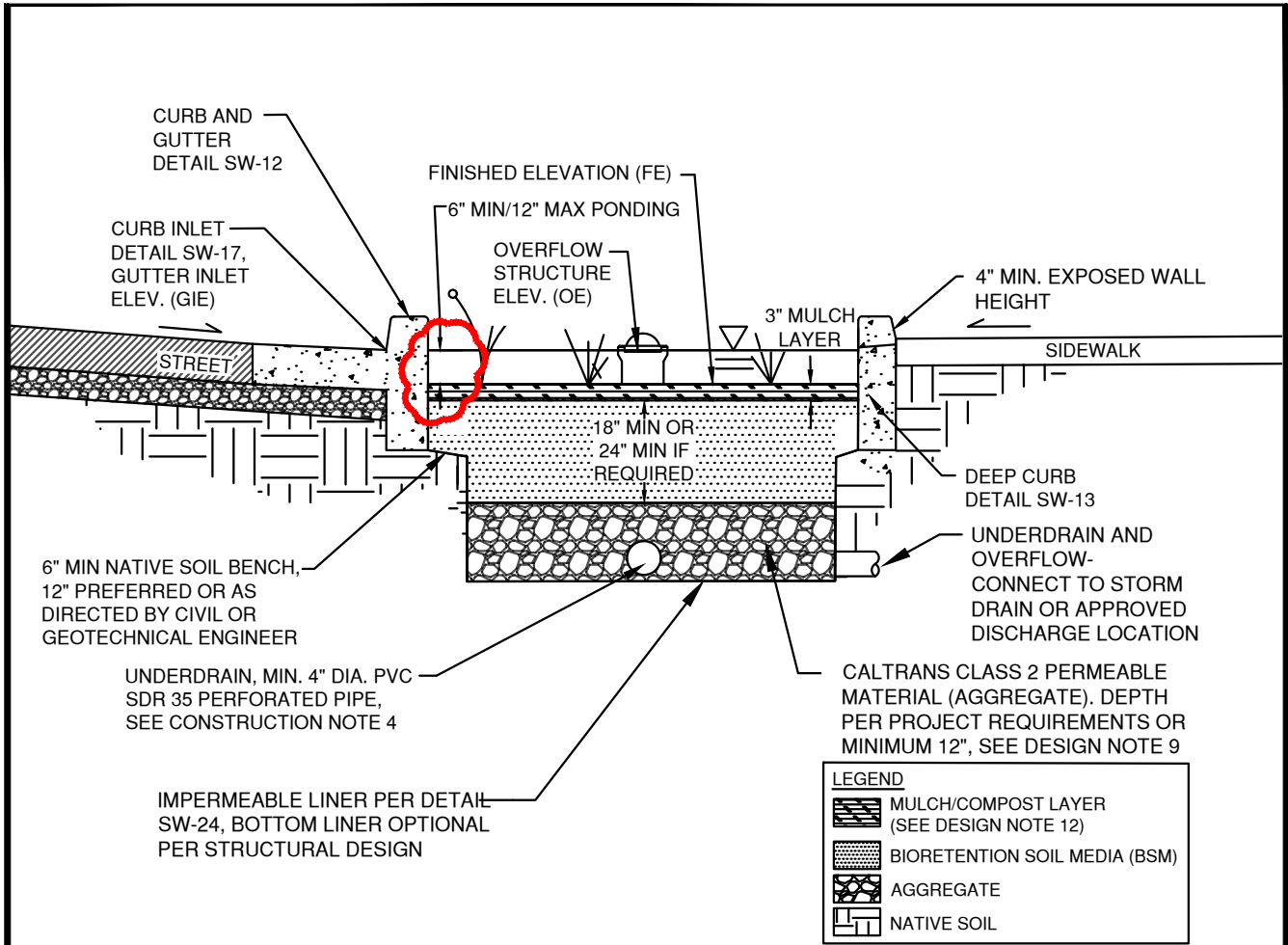

| LEGEND |  |
|--------|--|
|        | MULCH/COMPOST LAYER (SEE DESIGN NOTE 12) |
|        | BIORETENTION SOIL MEDIA (BSM)            |
|        | AGGREGATE                                |
|        | NATIVE SOIL                              |

**CONSTRUCTION NOTES**

1. MAINTAIN UNDISTURBED NATIVE SOIL BENCH TO SUPPORT ADJACENT SIDEWALK/ROAD. SEQUENCE WORK TO CONSTRUCT CURBS BEFORE EXCAVATING BIOFILTRATION AREA FOR AGGREGATE AND BSM.
2. SCARIFY SUBGRADE BEFORE INSTALLING BIORETENTION AREA AGGREGATE AND BSM.
3. FACILITY EXCAVATION TO ALLOW FOR SPECIFIED AGGREGATE, BSM, AND MULCH DEPTHS TO ACHIEVE FINISHED ELEVATIONS ON CIVIL PLANS.
4. COMPACT EACH 6" LIFT OF BSM WITH LANDSCAPE ROLLER OR BY LIGHTLY WETTING. IF WETTING, LET DRY OVERNIGHT BEFORE PLANTING.
5. DO NOT WORK WITHIN BIOFILTRATION AREA DURING RAIN OR UNDER WET CONDITIONS.
6. KEEP HEAVY MACHINERY OUTSIDE BIOFILTRATION AREA LIMITS.
7. STORMWATER SHOULD BE DIRECTED AWAY FROM BIOFILTRATION UNTIL CONSTRUCTION IS COMPLETE AND DRAINAGE AREA VEGETATION IS STABILIZED.

**NOTE: VTA CHANGED THE DEPTH OF PONDING TO REFLECT CASQA'S RECOMMENDATIONS FOUND IN THE DOCUMENT, "TECHNICAL MEMORANDUM #1 BIORETENTION DETAILS AND STANDARDS REVIEW."**

**LOW IMPACT DEVELOPMENT STORMWATER MANAGEMENT STANDARD DETAILS**



|   |                        |  |                   |
|---|------------------------|--|-------------------|
| DEVELOPED UNDER PROP. 84 GRANT                                | APPROVED BY:           | BIOFILTRATION PLANTER BOX,<br>NO PARKING | STANDARD PLAN NO. |
|   | VERSION:<br>08/31/2017 |  | SW-9              |
| USE WITH STANDARD SPECIFICATIONS FOR PUBLIC WORK CONSTRUCTION |                        | SHEET 1 OF 2                             |                   |



DESIGN NOTES

1. BIOFILTRATION FACILITY DESIGN SHOULD OPTIMIZE THE FLAT BOTTOM DIMENSIONS (I.E., WIDTH, LENGTH) TO MAXIMIZE THE FUNCTIONAL AREA OF THE FACILITY.
2. CAPTURE AND CONVEY OVERFLOW TO STORM DRAIN SYSTEM (DETAIL SW-22, SW-23). ALTERNATIVELY, CONVEY OVERFLOW TO APPROVED DISCHARGE LOCATION THROUGH OTHER OVERLAND METHODS (IE. CURB CUTS, SIDEWALK UNDERDRAIN, WEIR, ETC.).
3. PROVIDE SPOT ELEVATIONS AT INLETS AND OVERFLOW STRUCTURES ON CIVIL PLANS (FE,OE, GIE, SIE), PER DETAIL SW-18.
4. DUE TO SITE VARIABILITY, TO ENSURE THE LONG-TERM STRUCTURAL STABILITY OF THE BIOFILTRATION FACILITY AND ANY ADJACENT INFRASTRUCTURE CONSULT WITH A GEOTECHNICAL ENGINEER.
5. DO NOT USE FILTER FABRIC BETWEEN BSM AND AGGREGATE.
6. PROVIDE CAPPED, THREADED PVC CLEANOUT FOR UNDERDRAIN, 4" MIN. DIA. WITH SWEEP BEND.
7. PROVIDE A CLEAN-OUT/OBSERVATION PORT IN EACH FACILITY, PER BIORETENTION TECHNICAL SPECIFICATIONS.
8. ON LONGITUDINAL SLOPE, USE CHECK DAMS (DETAILS SW-20, SW-21)
9. USE AND DEPTH OF AGGREGATE DETERMINED BY FACILITY SIZING. IF CALTRANS CLASS 2 PERMEABLE IS NOT AVAILABLE, SUBSTITUTE CLASS 3 PERMEABLE WITH AN OVERLYING 3" DEEP CHOKING LAYER OF EITHER CALTRANS COURSE AGGREGATE 1/2" (NO. 4) OR 3/4" X (NO. 4) OPEN-GRADED AGGREGATE.
10. BIORETENTION SOIL MEDIA (BSM) SPECIFICATION PER BIORETENTION TECHNICAL SPECIFICATIONS.
11. PLANT SELECTION PER BIORETENTION TECHNICAL SPECIFICATIONS.
12. MULCH PER BIORETENTION TECHNICAL SPECIFICATIONS.
13. LOCATE ENERGY DISSIPATION AS SPECIFIED IN INLET DETAILS.
14. AVOID DECORATIVE USE OF COBBLE THAT CAN INTERFERE WITH WITH INFILTRATION.

LOW IMPACT DEVELOPMENT STORMWATER MANAGEMENT STANDARD DETAILS

|   |                        |  |   |
|---|------------------------|--|---|
|   <p>DEVELOPED UNDER PROP. 84 GRANT</p> | APPROVED BY:           | <p>BIOFILTRATION PLANTER BOX,<br/>NO PARKING</p> | STANDARD PLAN NO.   |
|   | VERSION:<br>08/31/2017 |  | USE WITH STANDARD SPECIFICATIONS FOR PUBLIC WORK CONSTRUCTION |



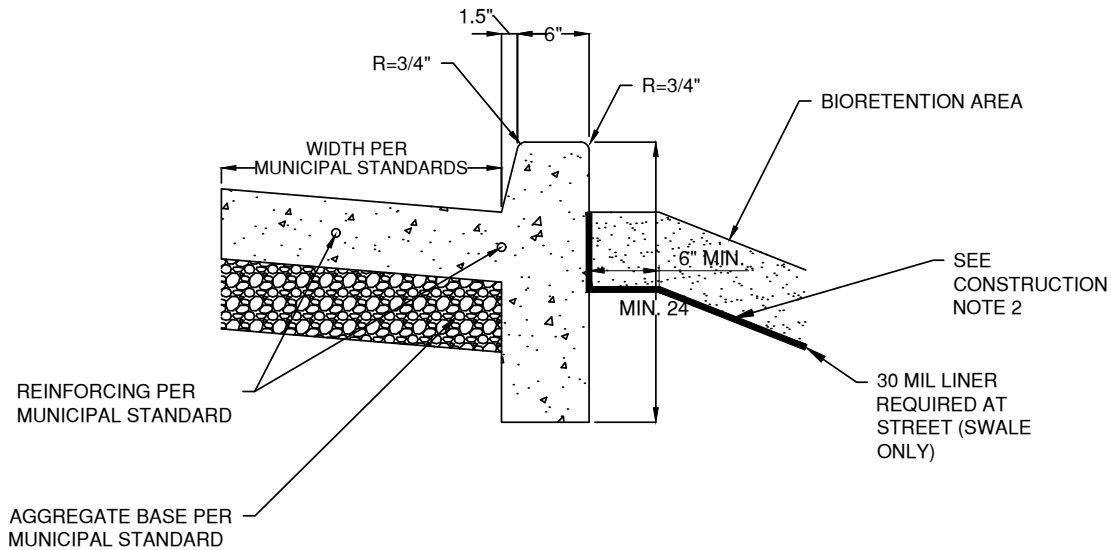



**DESIGN NOTES**

1. SPECIAL DESIGN CONSIDERATION OR STRUCTURAL REVIEW MAY BE REQUIRED FOR LONGER PLANTER WALL SPANS. STEEL REINFORCEMENT OR ADDITIONAL CONCRETE CHECK DAMS MAY BE NEEDED FOR STABILITY.
2. EDGE CONDITION WILL VARY FOR NEW AND RETROFIT PROJECTS. CURB, GUTTER, AND WALL DETAILS MAY BE MODIFIED BY CIVIL AND GEOTECHNICAL ENGINEERS SUBJECT TO APPROVAL BY CITY ENGINEER.
3. CONCRETE AND EXPANSION JOINTS SHALL MEET THE REQUIREMENTS OF THE MUNICIPALITY.
4. STEEL REINFORCEMENT OR ADDITIONAL CONCRETE CHECK DAMS MAY BE NEEDED FOR STABILITY.

**CONSTRUCTION NOTES**

1. FINISH ALL EXPOSED CONCRETE SURFACES.
2. LAYBACK SLOPE AS FLAT AS POSSIBLE UNTIL TOP WIDTH PRODUCES 1:1 SLOPE & 24" BOTTOM WIDTH. AS PLANTER GETS WIDER MAINTAIN 1:1 SLOPE AND INCREASE BOTTOM WIDTH WIDER THAN 24". ALTERNATIVE TRENCH WALL CONFIGURATIONS MAY BE PROPOSED BY THE PROJECT GEOTECHNICAL ENGINEER (I.E. VERTICAL SHORING, REINFORCED TRENCH SIDEWALL) THAT DO NOT REQUIRE SIDEWALK SUPPORT FROM THE LIGHTLY COMPACTED BSM.

**LOW IMPACT DEVELOPMENT STORMWATER MANAGEMENT STANDARD DETAILS**

|   |                        |                        |   |
|---|------------------------|------------------------|---|
|  <br>DEVELOPED UNDER PROP. 84 GRANT | APPROVED BY:           | <b>CURB AND GUTTER</b> | STANDARD PLAN NO.   |
|   | VERSION:<br>08/31/2017 |                        | USE WITH STANDARD SPECIFICATIONS FOR PUBLIC WORK CONSTRUCTION |

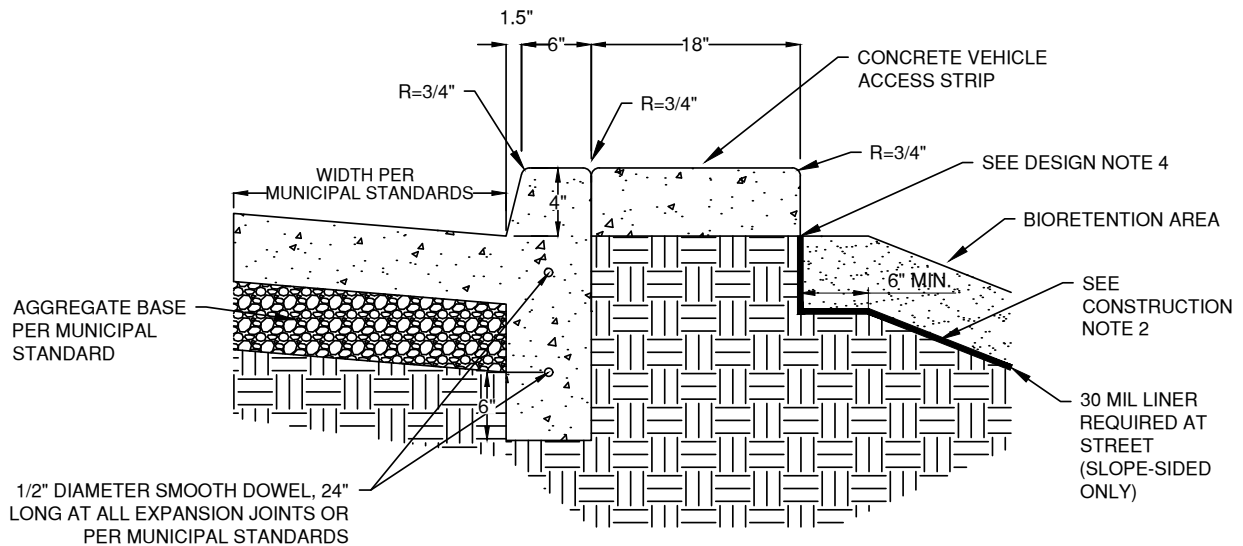



DESIGN NOTES

1. SPECIAL CONCRETE AND EXPANSION JOINTS SHALL MEET THE REQUIREMENTS OF THE MUNICIPALITY.
2. PROVIDE OPENINGS IN CURB (12" WIDE) TO ALLOW FOR SURFACE DRAINAGE TO BIORETENTION AREAS IF DEDICATED INLET NOT USED. SPACING TO BE DETERMINED BY PROJECT ENGINEER BASED ON DESIGN STORM TO MINIMIZE PONDING AGAINST CURB FOR MEDIAN ISLAND APPLICATION.
3. STEEL REINFORCEMENT OR ADDITIONAL CONCRETE CHECK DAMS MAY BE NEEDED FOR STABILITY.
4. SEE REFERENCE DETAIL SW-24 FOR ATTACHMENT OF IMPERVIOUS LINER.

CONSTRUCTION NOTES

1. FINISH ALL EXPOSED CONCRETE SURFACES.
2. LAYBACK SLOPE AS FLAT AS POSSIBLE UNTIL TOP WIDTH PRODUCES 1:1 SLOPE & 24" BOTTOM WIDTH. AS PLANTER GETS WIDER MAINTAIN 1:1 SLOPE AND INCREASE BOTTOM WIDER THAN 24". ALTERNATIVE TRENCH WALL CONFIGURATIONS MAY BE PROPOSED BY THE PROJECT GEOTECHNICAL ENGINEER (I.E. VERTICAL SHORING, REINFORCED TRENCH SIDEWALL) THAT DO NOT REQUIRE SIDEWALK SUPPORT FROM THE LIGHTLY COMPACTED BSM.

LOW IMPACT DEVELOPMENT STORMWATER MANAGEMENT STANDARD DETAILS

|   |                        |                        |   |
|---|------------------------|------------------------|---|
|   <p>DEVELOPED UNDER PROP. 84 GRANT</p> | APPROVED BY:           | <p>CURB AND GUTTER</p> | STANDARD PLAN NO.   |
|   | VERSION:<br>08/31/2017 |                        | USE WITH STANDARD SPECIFICATIONS FOR PUBLIC WORK CONSTRUCTION |

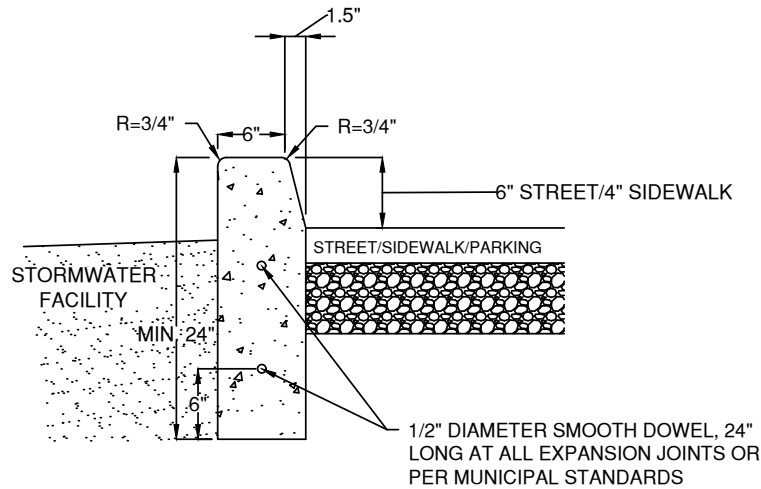

**DESIGN NOTES**

1. SPECIAL DESIGN CONSIDERATION OR STRUCTURAL REVIEW MAY BE REQUIRED FOR LONGER SWALE EDGE SPANS. STEEL REINFORCEMENT OR ADDITIONAL CONCRETE CHECK DAMS MAY BE NEEDED FOR STABILITY.
2. WHEN SIDEWALK DRAINS TO PLANTER, PROVIDE 4" - 6" WIDE NOTCH OPENINGS, 1" BELOW SIDEWALK, SLOPED TO FACILITY, PER BIORETENTION PLANTER DETAILS. SPACE OPENINGS TO CONVEY FLOWS. PROVIDE MINIMUM 2" COVER BETWEEN DRAINAGE NOTCH OPENING AND DOWELS.
3. CONCRETE AND EXPANSION JOINTS SHALL MEET THE REQUIREMENTS OF THE MUNICIPALITY.
4. STEEL REINFORCEMENT OR ADDITIONAL CONCRETE CHECK DAMS MAY BE NEEDED FOR STABILITY.

**CONSTRUCTION NOTES**

1. FINISH ALL EXPOSED CONCRETE SURFACES.
2. LAYBACK SLOPE AS FLAT AS POSSIBLE UNTIL TOP WIDTH PRODUCES 1:1 SLOPE & 24" BOTTOM WIDTH. AS PLANTER GETS WIDER MAINTAIN 1:1 SLOPE AND INCREASE BOTTOM WIDTH WIDER THAN 24". ALTERNATIVE TRENCH WALL CONFIGURATIONS MAY BE PROPOSED BY THE PROJECT GEOTECHNICAL ENGINEER (I.E. VERTICAL SHORING, REINFORCED TRENCH SIDEWALL) THAT DO NOT REQUIRE SIDEWALK SUPPORT FROM THE LIGHTLY COMPACTED BSM.

**LOW IMPACT DEVELOPMENT STORMWATER MANAGEMENT STANDARD DETAILS**

|   |                        |                         |   |
|---|------------------------|-------------------------|---|
|   <p>DEVELOPED UNDER PROP. 84 GRANT</p> | APPROVED BY:           | <p><b>DEEP CURB</b></p> | STANDARD PLAN NO.   |
|   | VERSION:<br>08/31/2017 |                         | USE WITH STANDARD SPECIFICATIONS FOR PUBLIC WORK CONSTRUCTION |

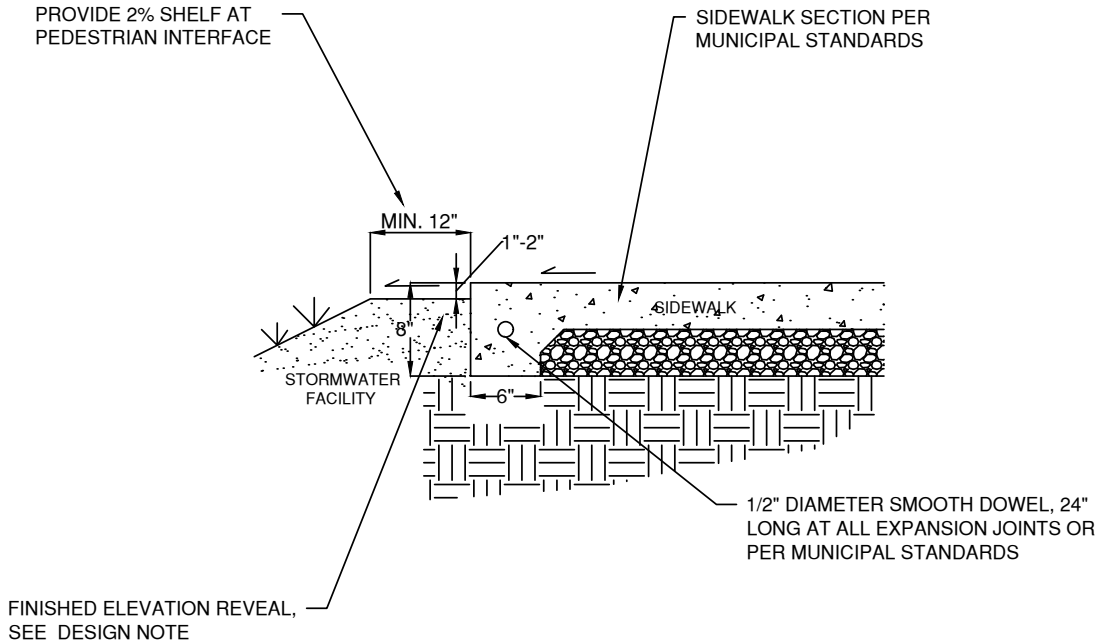

DESIGN NOTES

1. SPECIAL DESIGN CONSIDERATION OR STRUCTURAL REVIEW MAY BE REQUIRED FOR LONGER FACILITY EDGE SPANS. STEEL REINFORCEMENT OR ADDITIONAL CONCRETE CHECK DAMS MAY BE NEEDED FOR STABILITY.
2. FINISHED ELEVATION REVEAL - WHERE SIDEWALK CONVEYS SHEET FLOW TO FACILITY, A 1"-2" REVEAL SHOULD BE MAINTAINED BETWEEN SIDEWALK AND FACILITY FINISHED GRADE TO AVOID MULCH OR PLANT BUILDUP FROM BLOCKING FLOWS.
3. CONCRETE AND EXPANSION JOINTS SHALL MEET THE REQUIREMENTS OF THE MUNICIPALITY.

CONSTRUCTION NOTES

1. FINISH ALL EXPOSED CONCRETE SURFACES.

LOW IMPACT DEVELOPMENT STORMWATER MANAGEMENT STANDARD DETAILS

|   |                        |                         |   |
|---|------------------------|-------------------------|---|
|   <p>DEVELOPED UNDER PROP. 84 GRANT</p> | APPROVED BY:           | THICKENED EDGE SIDEWALK | STANDARD PLAN NO.   |
|   | VERSION:<br>08/31/2017 |                         | USE WITH STANDARD SPECIFICATIONS FOR PUBLIC WORK CONSTRUCTION |

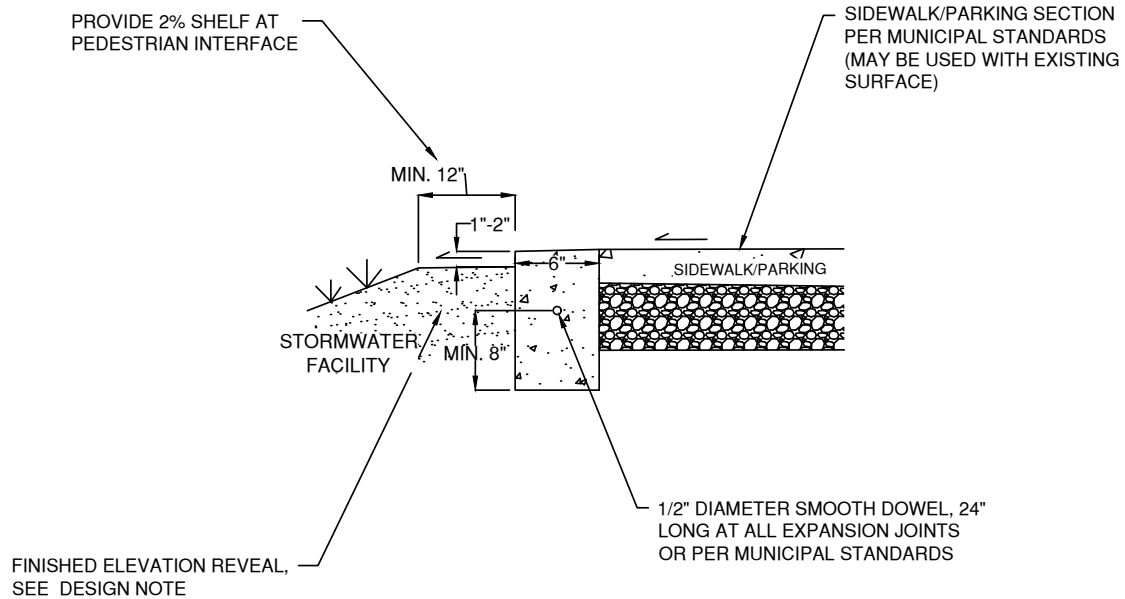

**DESIGN NOTES**

1. SPECIAL DESIGN CONSIDERATION OR STRUCTURAL REVIEW MAY BE REQUIRED FOR LONGER FACILITY EDGE SPANS. STEEL REINFORCEMENT OR ADDITIONAL CONCRETE CHECK DAMS MAY BE NEEDED FOR STABILITY.
2. EDGE CONDITION WILL VARY FOR PROJECTS. CURB DETAILS MAY BE MODIFIED BY CIVIL AND GEOTECHNICAL ENGINEERS SUBJECT TO APPROVAL BY CITY ENGINEER.
3. CONCRETE AND EXPANSION JOINTS SHALL MEET THE REQUIREMENTS OF THE MUNICIPALITY.
4. FINISHED ELEVATION REVEAL AT SIDEWALK - WHERE SIDEWALK CONVEYS SHEET FLOW TO FACILITY, A 1"-2" REVEAL SHOULD BE MAINTAINED BETWEEN SIDEWALK AND FACILITY FINISHED GRADE TO AVOID MULCH OR PLANT BUILDUP FROM BLOCKING FLOWS AND REDUCE DROP AT PEDESTRIAN INTERFACE.

**CONSTRUCTION NOTES**

1. FINISH ALL EXPOSED CONCRETE SURFACES.

LOW IMPACT DEVELOPMENT STORMWATER MANAGEMENT STANDARD DETAILS



DEVELOPED UNDER PROP. 84 GRANT

APPROVED BY:

VERSION:

08/31/2017

FLUSH CURB AT SIDEWALK

USE WITH STANDARD SPECIFICATIONS FOR PUBLIC WORK CONSTRUCTION

STANDARD PLAN NO.

SW-15

SHEET 1 OF 1



DEEP CURB  
DETAIL SW-13

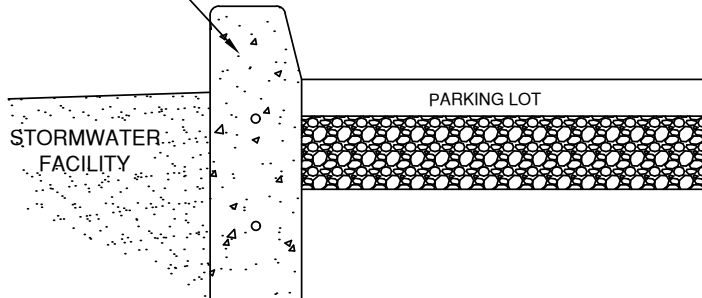

DEEP CURB

CURB AND  
GUTTER  
DETAILSW-12

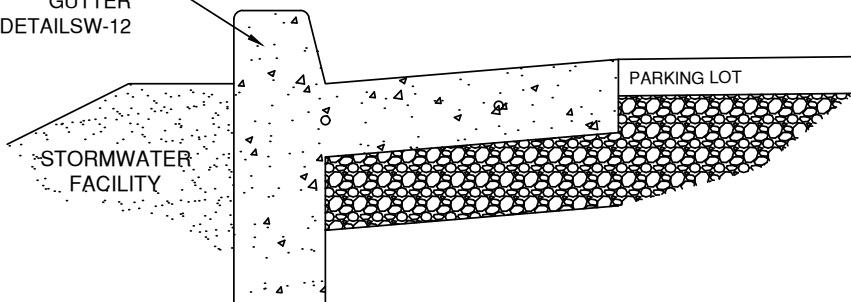

CURB AND GUTTER

FLUSH CURB  
DETAIL SW-15

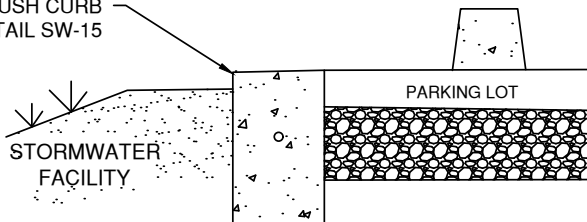

FLUSH EDGE/WHEEL STOPS

**DESIGN NOTES**

1. WHEEL STOPS MAY BE USED ON NON-FLUSH DESIGNS TO KEEP CARS FROM OVERHANGING BIORETENTION FACILITY.
2. VEHICLE OVERHANG CAN BE USED TO REDUCE IMPERVIOUS PAVEMENT AREA.
3. WHERE VEHICLE OVERHANG IS UTILIZED SELECT LOW GROWING PLANTS THAT WILL TOLERATE SHADING.

**LOW IMPACT DEVELOPMENT STORMWATER MANAGEMENT STANDARD DETAILS**



DEVELOPED UNDER PROP. 84 GRANT

APPROVED BY:

VERSION:

08/31/2017

PARKING LOT EDGE OPTIONS

USE WITH STANDARD SPECIFICATIONS FOR PUBLIC WORK CONSTRUCTION

STANDARD PLAN NO.

**SW-16**

SHEET 1 OF 1

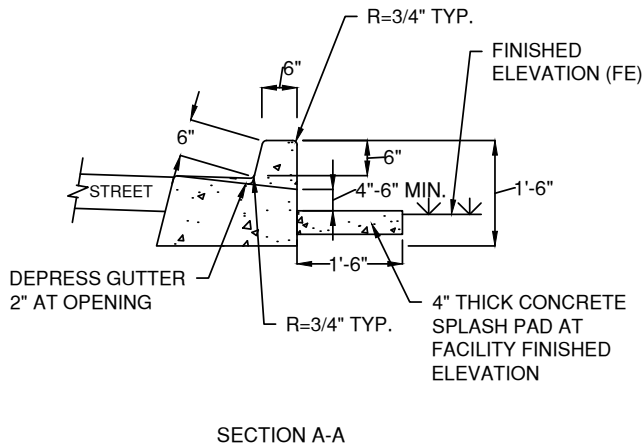
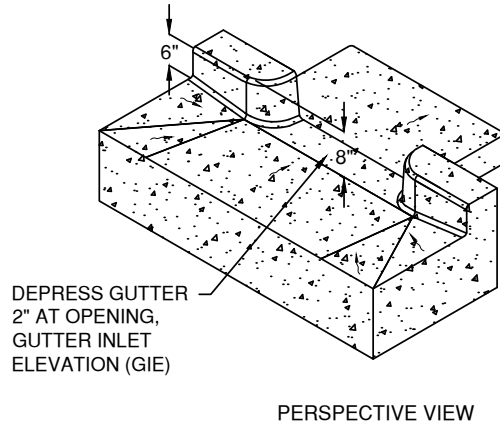
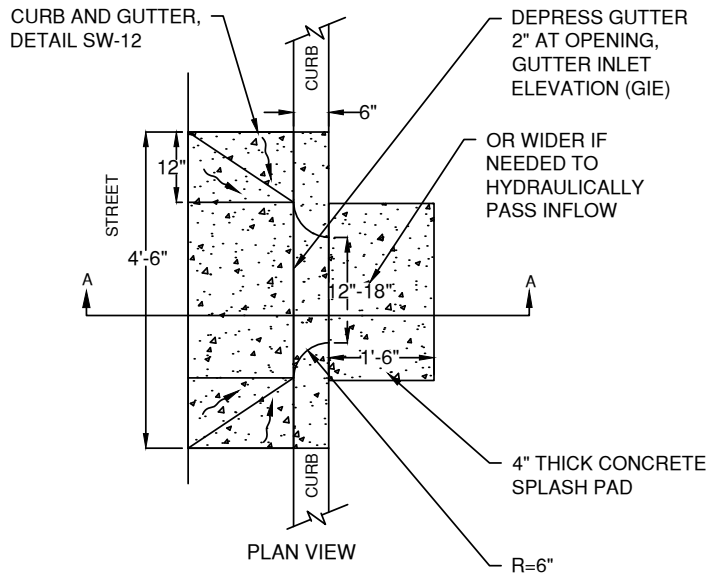

**BIORETENTION DESIGN NOTES**

1. FOR USE WITH STORMWATER FACILITIES WITH FLAT BOTTOMS.
2. PROVIDE SPOT ELEVATIONS ON PLANS (FE, OE, GIE, IE). SEE DETAIL SW-2, SW-2A, SW-4 OR SW-4A.
3. CURB AND WALL DETAILS MAY BE MODIFIED BY CIVIL AND GEOTECHNICAL ENGINEERS SUBJECT TO APPROVAL BY CITY ENGINEER.
4. CURB HEIGHT MAY BE REDUCED TO 4-INCHES WHERE ADJACENT TO A SIDEWALK. SEE DETAILS SW-12 & SW-13.

**CONSTRUCTION NOTES**

1. AFTER CONSTRUCTION PLACE SAND BAGS AT GUTTER OPENINGS TO KEEP STORM FLOWS FROM ENTERING FACILITY UNTIL VEGETATION IS ESTABLISHED.

LOW IMPACT DEVELOPMENT STORMWATER MANAGEMENT STANDARD DETAILS



DEVELOPED UNDER PROP. 84 GRANT

APPROVED BY:

VERSION:  
08/31/2017

CURB CUT INLET FOR PLANTERS

USE WITH STANDARD SPECIFICATIONS FOR PUBLIC WORK CONSTRUCTION

STANDARD PLAN NO.

SW-17

SHEET 1 OF 1

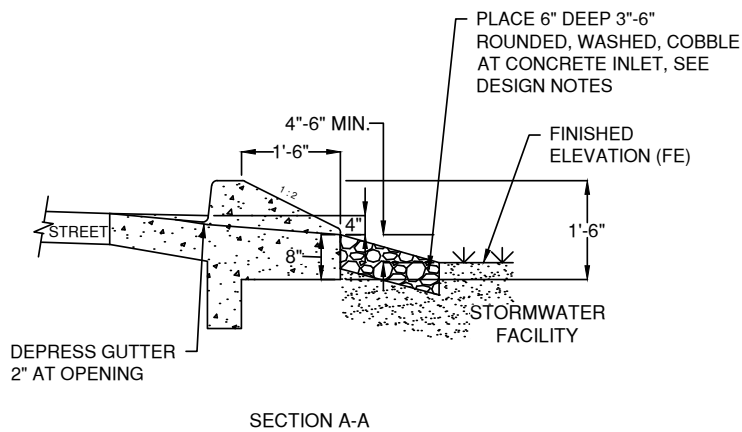
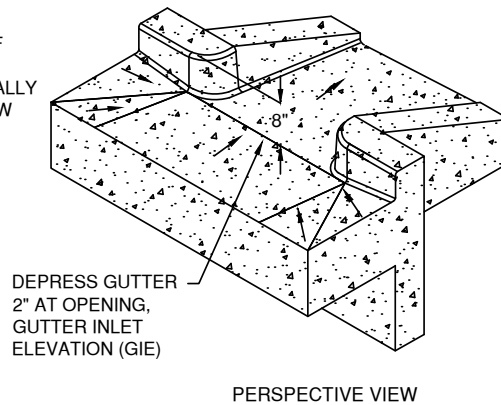
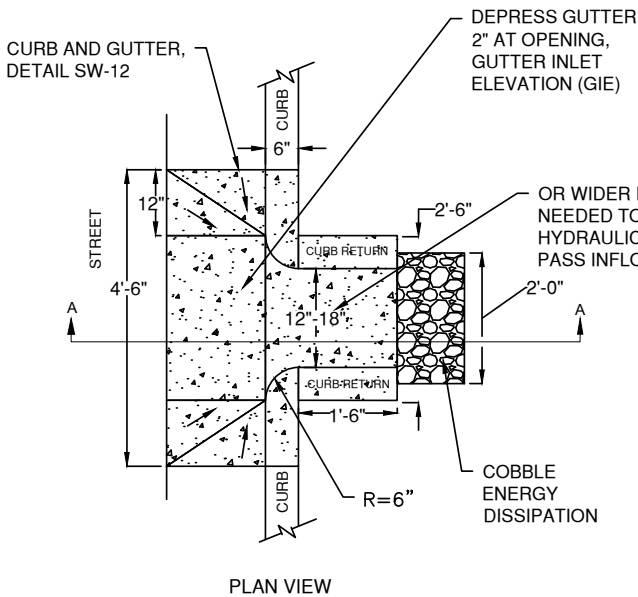

**BIORETENTION DESIGN NOTES**

1. FOR USE WITH STORMWATER FACILITIES WITH SIDE SLOPES.
2. PROVIDE SPOT ELEVATIONS ON PLANS (FE, OE, GIE, IE). SEE DETAIL SW-1, SW-1A, SW-3 OR SW-3A.
3. CURB AND WALL DETAILS MAY BE MODIFIED BY CIVIL AND GEOTECHNICAL ENGINEERS SUBJECT TO APPROVAL BY CITY ENGINEER.
4. WHERE INLET FLOW VELOCITY IS HIGH, EXTEND COBBLE INTO FACILITY, BUT AVOID EXCESSIVE USE.
5. CURB HEIGHT MAY BE REDUCED TO 4-INCHES WHERE ADJACENT TO A SIDEWALK. SEE DETAILS SW-12 & SW-13.

**CONSTRUCTION NOTES**

1. AFTER CONSTRUCTION PLACE SAND BAGS AT GUTTER OPENINGS TO KEEP STORM FLOWS FROM ENTERING FACILITY UNTIL VEGETATION IS ESTABLISHED.

**LOW IMPACT DEVELOPMENT STORMWATER MANAGEMENT STANDARD DETAILS**



DEVELOPED UNDER PROP. 84 GRANT

APPROVED BY:

VERSION:

08/31/2017

**CURB CUT INLET FOR SLOPE SIDED  
BIORETENTION SWALE**

USE WITH STANDARD SPECIFICATIONS FOR PUBLIC WORK CONSTRUCTION

STANDARD PLAN NO.

**SW-18**

SHEET 1 OF 1



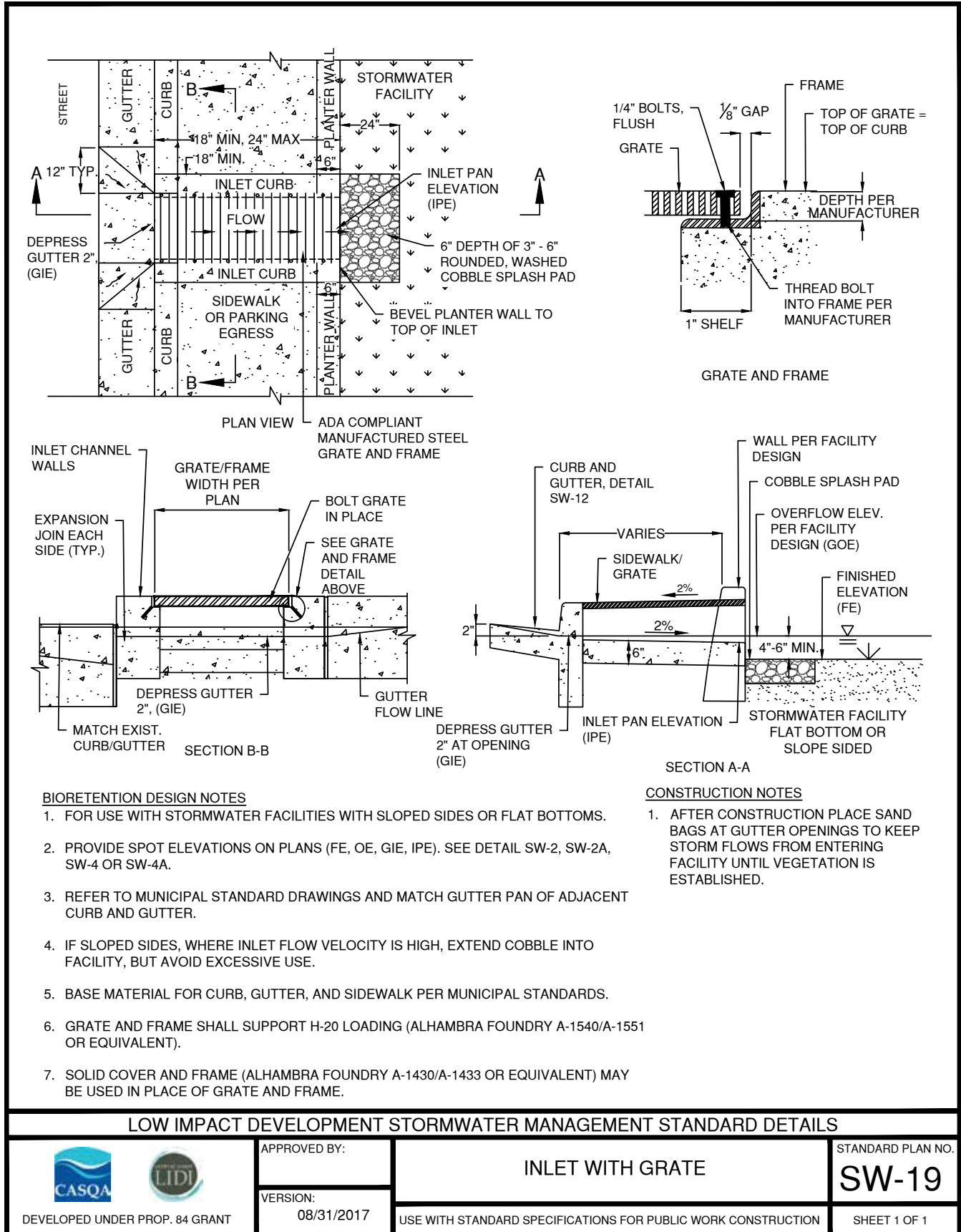



CURB AND GUTTER  
PER BIORETENTION  
WITH SIDESLOPE  
DETAIL

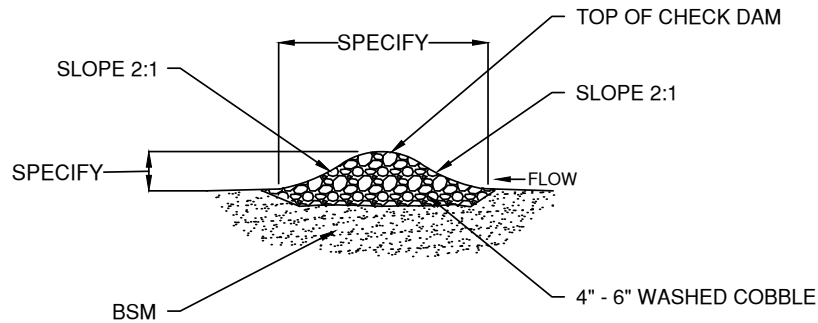
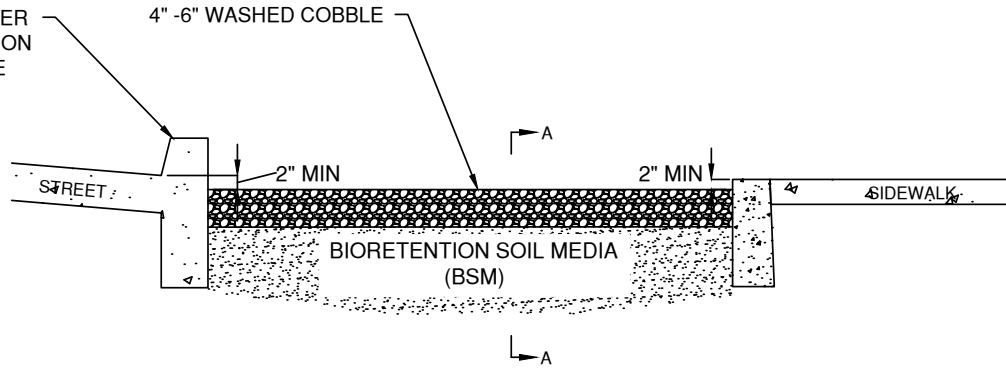

SECTION A-A

**BIORETENTION DESIGN NOTES**

1. FOR USE WITH STORMWATER FACILITIES WITH SLOPED SIDES.
2. BEST SUITED FOR FACILITIES WITH  $\leq 2\%$  LONGITUDINAL SLOPE.
3. PROVIDE ELEVATIONS AND STATIONING AND/OR DIMENSIONING FOR CHECK DAMS.
4. SPACE CHECK DAMS TO MAXIMIZE PONDING ACROSS ENTIRE CELL.
5. ENSURE THAT CHECK DAM ELEVATIONS DO NOT CAUSE STORMWATER TO OVERFLOW TO SIDEWALK.

**CONSTRUCTION NOTES**

1. DO NOT WORK DURING RAIN OR UNDER WET CONDITIONS.
2. KEEP ALL HEAVY MACHINERY OUTSIDE BIORETENTION AREA LIMITS.

LOW IMPACT DEVELOPMENT STORMWATER MANAGEMENT STANDARD DETAILS



DEVELOPED UNDER PROP. 84 GRANT

APPROVED BY:

VERSION:

08/31/2017

GRAVEL CHECK DAM

USE WITH STANDARD SPECIFICATIONS FOR PUBLIC WORK CONSTRUCTION

STANDARD PLAN NO.

SW-20

SHEET 1 OF 1

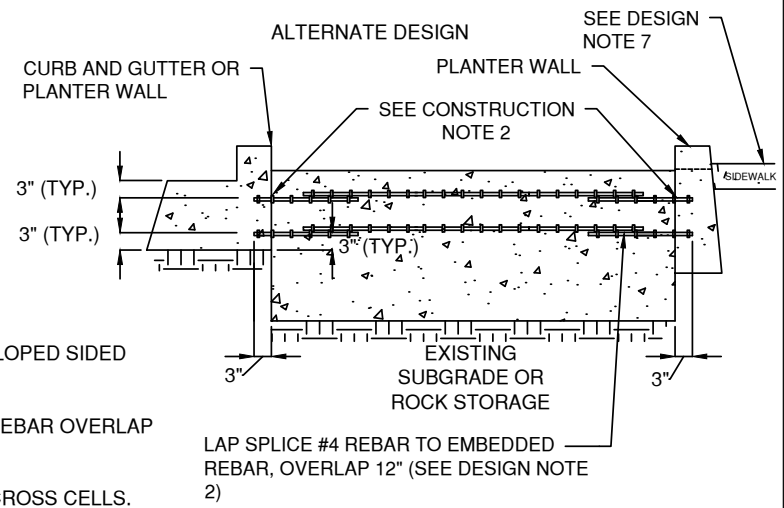
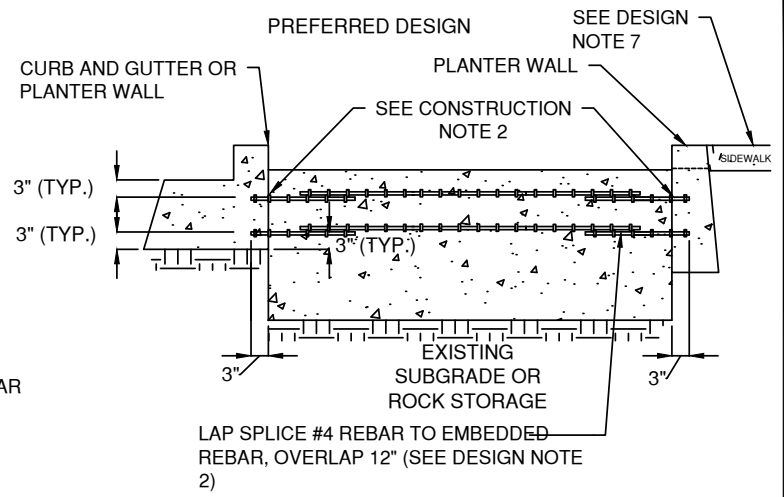
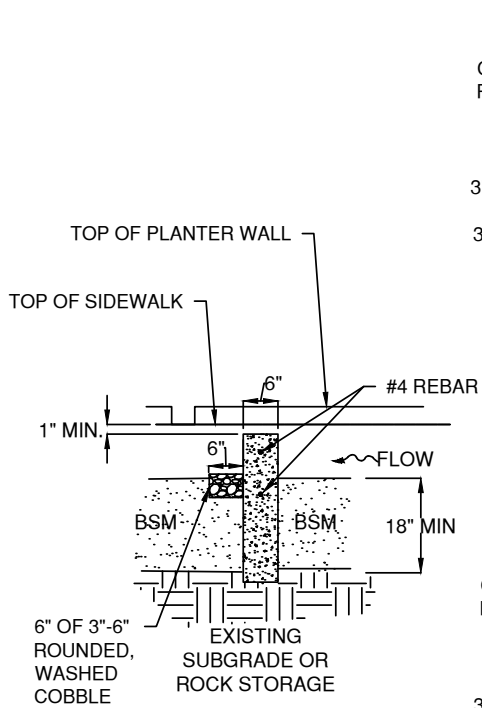

**BIORETENTION DESIGN NOTES**

1. FOR USE WITH BIORETENTION PLANTERS OR SLOPED SIDED SWALES/RAIN GARDENS.
2. FOR CHECK DAMS LONGER THAN 12' SPECIFY REBAR OVERLAP LENGTH.
3. SPACE CHECK DAMS TO MAXIMIZE PONDING ACROSS CELLS.
4. PROVIDE ELEVATIONS AND STATIONING AND/OR DIMENSIONING FOR CHECK DAMS.
5. ENSURE THAT CHECK DAM ELEVATIONS DO NOT CAUSE STORMWATER TO OVERFLOW TO SIDEWALK.
6. SHOW PLANTER WALL EMBEDDED IN EXISTING SUBGRADE OR DRAINROCK.
7. PREFERRED DESIGN IS TO CONSTRUCT TOP OF SIDEWALK AT GRADE WITH TOP OF PLANTER WALL TO ALLOW RUNOFF TO SHEETFLOW INTO BIORETENTION PLANTER. IF CURB IS NEEDED, USE ALTERNATE DESIGN AND ENSURE TOP OF CONCRETE CHECK DAM IS A MINIMUM OF 1" BELOW BOTTOM OF CURB NOTCH.

**CONSTRUCTION NOTES**

1. EMBED #3 REBAR 3" INTO CURB AND PLANTER WALL.
2. DO NOT WORK DURING RAIN OR UNDER WET CONDITIONS.
3. KEEP ALL HEAVY MACHINERY OUTSIDE BIORETENTION AREA LIMITS.

**LOW IMPACT DEVELOPMENT STORMWATER MANAGEMENT STANDARD DETAILS**

|   |                        |                           |   |
|---|------------------------|---------------------------|---|
|  <br>DEVELOPED UNDER PROP. 84 GRANT | APPROVED BY:           | <b>CONCRETE CHECK DAM</b> | STANDARD PLAN NO.   |
|   | VERSION:<br>08/31/2017 |                           | USE WITH STANDARD SPECIFICATIONS FOR PUBLIC WORK CONSTRUCTION |

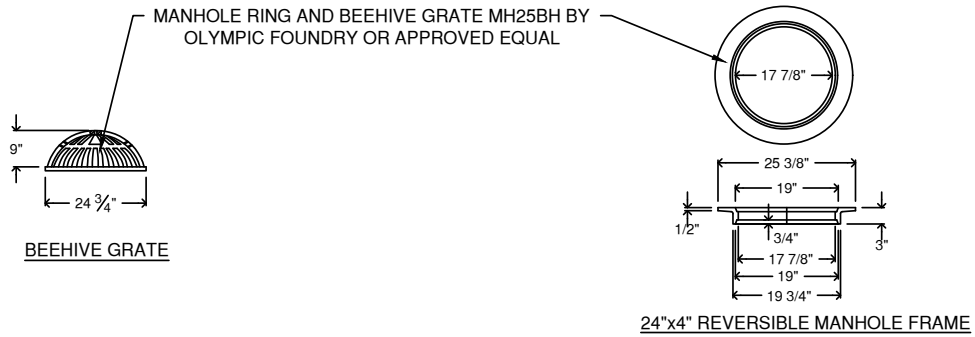
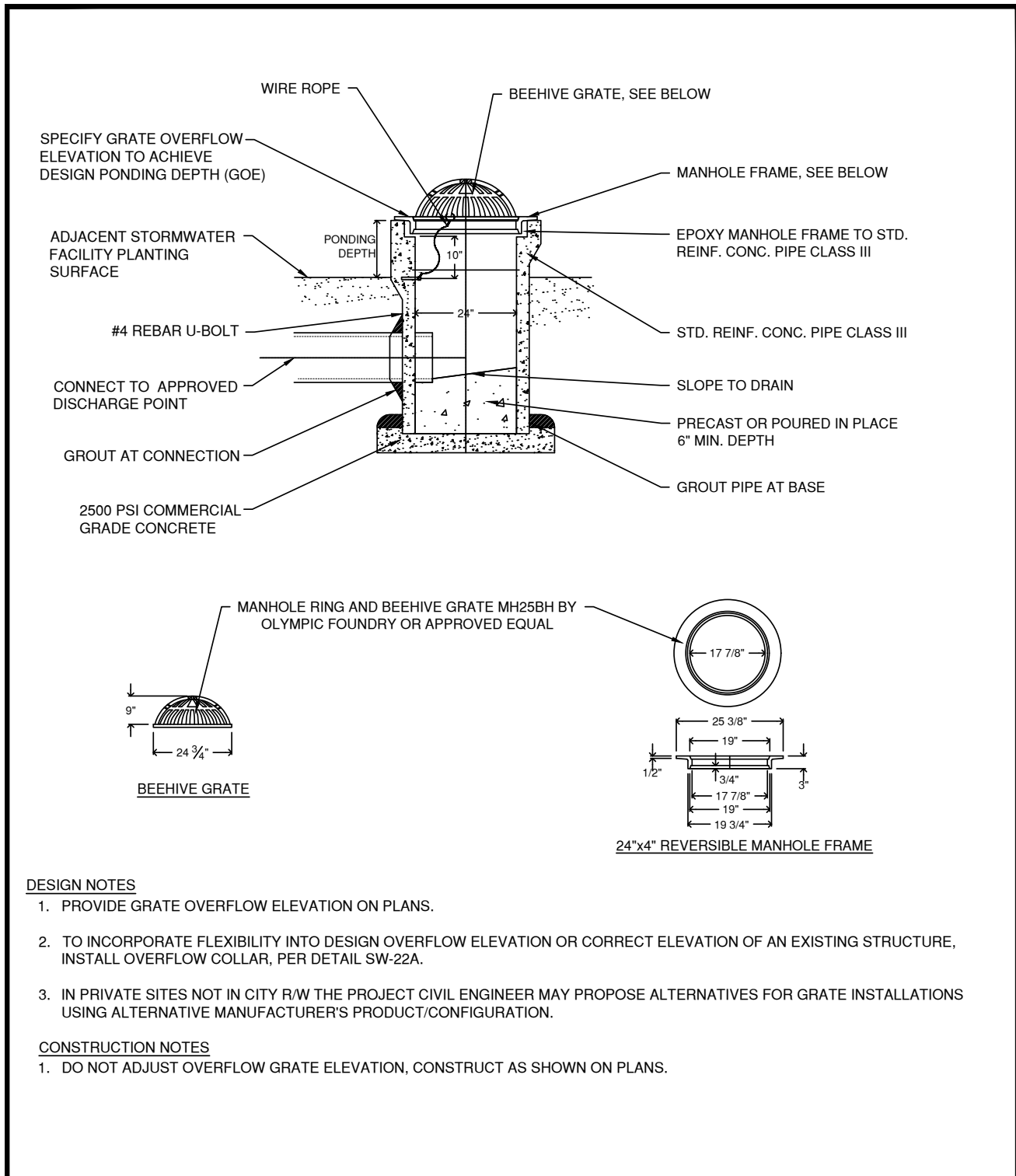

**DESIGN NOTES**

1. PROVIDE GRATE OVERFLOW ELEVATION ON PLANS.
2. TO INCORPORATE FLEXIBILITY INTO DESIGN OVERFLOW ELEVATION OR CORRECT ELEVATION OF AN EXISTING STRUCTURE, INSTALL OVERFLOW COLLAR, PER DETAIL SW-22A.
3. IN PRIVATE SITES NOT IN CITY R/W THE PROJECT CIVIL ENGINEER MAY PROPOSE ALTERNATIVES FOR GRATE INSTALLATIONS USING ALTERNATIVE MANUFACTURER'S PRODUCT/CONFIGURATION.

**CONSTRUCTION NOTES**

1. DO NOT ADJUST OVERFLOW GRATE ELEVATION, CONSTRUCT AS SHOWN ON PLANS.

**LOW IMPACT DEVELOPMENT STORMWATER MANAGEMENT STANDARD DETAILS**

|   |                                   |   |  |
|---|-----------------------------------|---|--|
|   <p>DEVELOPED UNDER PROP. 84 GRANT</p> | <p>APPROVED BY:</p>               | <p><b>OVERFLOW STRUCTURE WITH<br/>BEEHIVE GRATE</b></p> | <p>STANDARD PLAN NO.</p> <p><b>SW-22</b></p>                         |
|   | <p>VERSION:</p> <p>08/31/2017</p> |   | <p>USE WITH STANDARD SPECIFICATIONS FOR PUBLIC WORK CONSTRUCTION</p> |

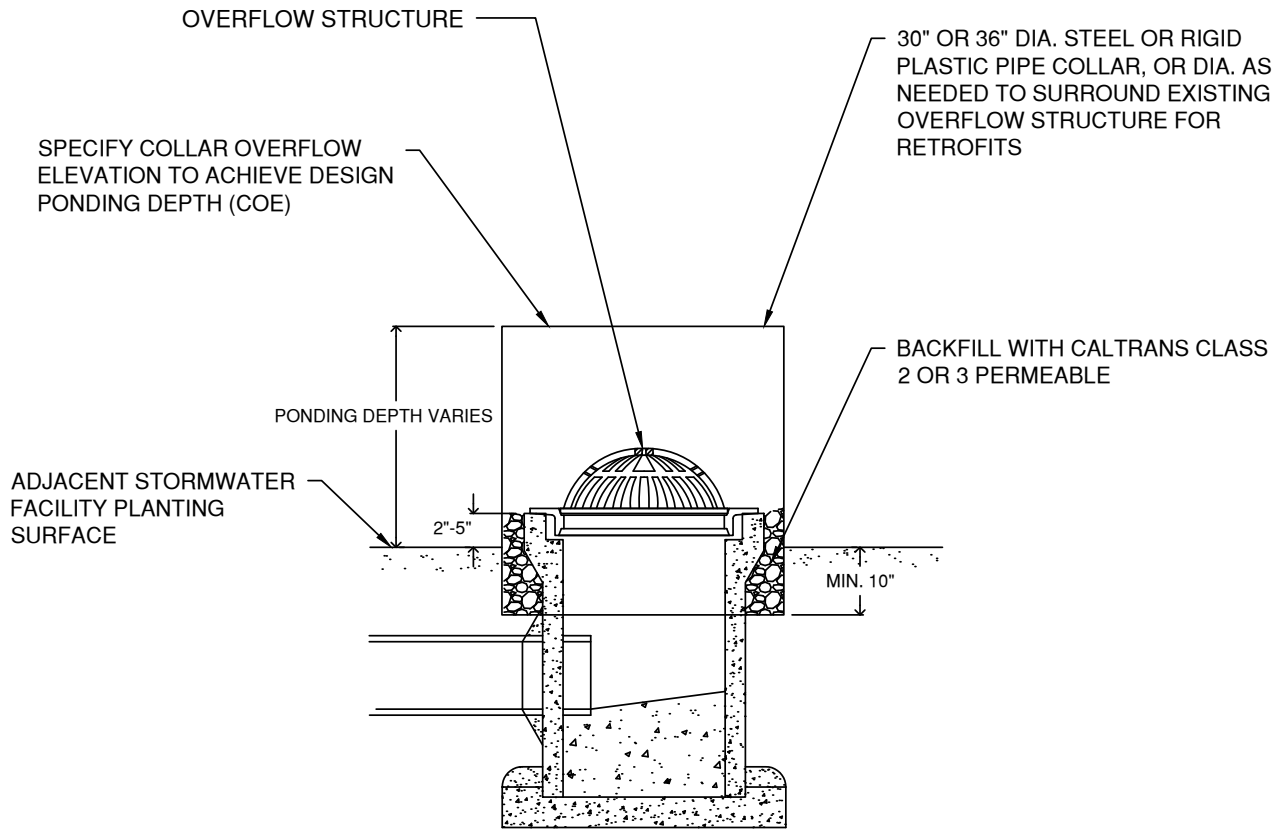

**DESIGN NOTES**

1. MAY BE USED IN CONJUNCTION WITH OVERFLOW STRUCTURES TO ALLOW FOR FIELD ADJUSTMENT OF OVERFLOW ELEVATION, OR AS RETROFIT TO CORRECT EXISTING STRUCTURE THAT DOES NOT ALLOW PONDING TO OCCUR.
2. PROVIDE COLLAR OVERFLOW ELEVATION (COE) ON PLANS.
3. PCC PIPE RISER EXTENSIONS MAY BE UTILIZED IN LIEU OF OVER FLOW STRUCTURE COLLAR.

**CONSTRUCTION NOTES**

1. CENTER COLLAR ON OVERFLOW GRATE.

LOW IMPACT DEVELOPMENT STORMWATER MANAGEMENT STANDARD DETAILS

|   |                        |                                  |   |
|---|------------------------|----------------------------------|---|
|  <br>DEVELOPED UNDER PROP. 84 GRANT | APPROVED BY:           | <b>OVERFLOW STRUCTURE COLLAR</b> | STANDARD PLAN NO.   |
|   | VERSION:<br>08/31/2017 |                                  | USE WITH STANDARD SPECIFICATIONS FOR PUBLIC WORK CONSTRUCTION |

C.I. GRATE

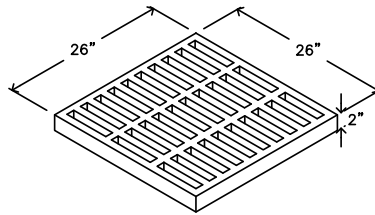

C.I. FRAME  
EXTENSION

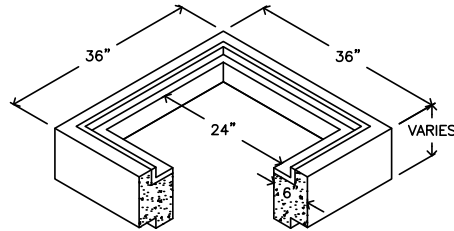

BOTTOM

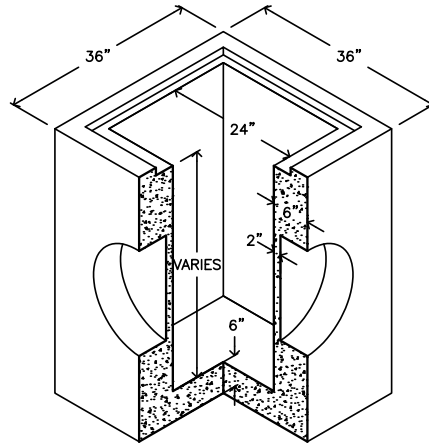

DESIGN NOTES

1. PROVIDE GRATE OVERFLOW ELEVATION ON PLANS.
2. PROVIDE EXTENSION OVERFLOW ELEVATION (COE) ON PLANS.
3. ON PRIVATE SITES NOT IN CITY RIGHT-OF-WAY THE PROJECT CIVIL ENGINEER MAY PROPOSE ALTERNATIVES FOR GRATE INSTALLATIONS USING ALTERNATIVE MANUFACTURER'S PRODUCTION/CONFIGURATION.

CONSTRUCTION NOTES

1. DO NOT ADJUST OVERFLOW GRATE ELEVATION, CONSTRUCT AS SHOWN ON PLANS.

LOW IMPACT DEVELOPMENT STORMWATER MANAGEMENT STANDARD DETAILS



DEVELOPED UNDER PROP. 84 GRANT

APPROVED BY:

VERSION:

08/31/2017

OVERFLOW STRUCTURE WITH  
SQUARE GRATE

USE WITH STANDARD SPECIFICATIONS FOR PUBLIC WORK CONSTRUCTION

STANDARD PLAN NO.

SW-23

SHEET 1 OF 1

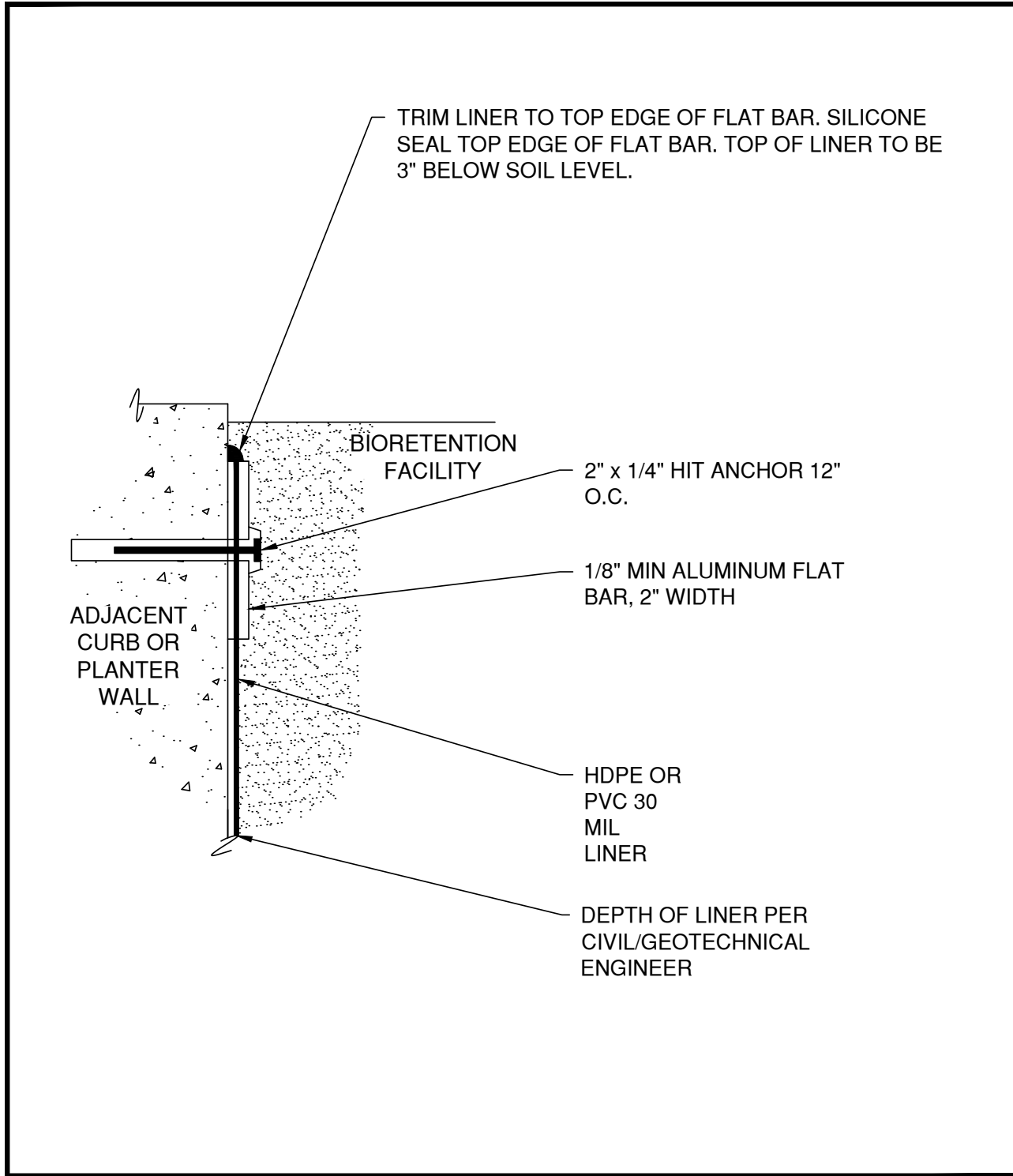

LOW IMPACT DEVELOPMENT STORMWATER MANAGEMENT STANDARD DETAILS

|   |                        |                              |   |
|---|------------------------|------------------------------|---|
|  <br>DEVELOPED UNDER PROP. 84 GRANT | APPROVED BY:           | IMPERMEABLE LINER CONNECTION | STANDARD PLAN NO.   |
|   | VERSION:<br>08/31/2017 |                              | USE WITH STANDARD SPECIFICATIONS FOR PUBLIC WORK CONSTRUCTION |



|                               | RESIDENTIAL DRIVEWAY OR PEDESTRIAN ONLY | PRIVATE STREET, PARKING LOT | PUBLIC STREET OR FIRE LANE |
|-------------------------------|---|-----------------------------|----------------------------|
| PERVIOUS CONCRETE             | 4"                                      | 6"                          | 8"                         |
| POROUS ASPHALT                | 3"                                      | 4"                          | 6"                         |
| PERMEABLE INTERLOCKING PAVERS | 2 3/8"                                  | 3 1/8"                      | 3 1/8"                     |
| ENGINEERING REQ'D             | NO                                      | YES                         | YES                        |
| COMPACTION REQ'D              | NO                                      | YES                         | 95%                        |

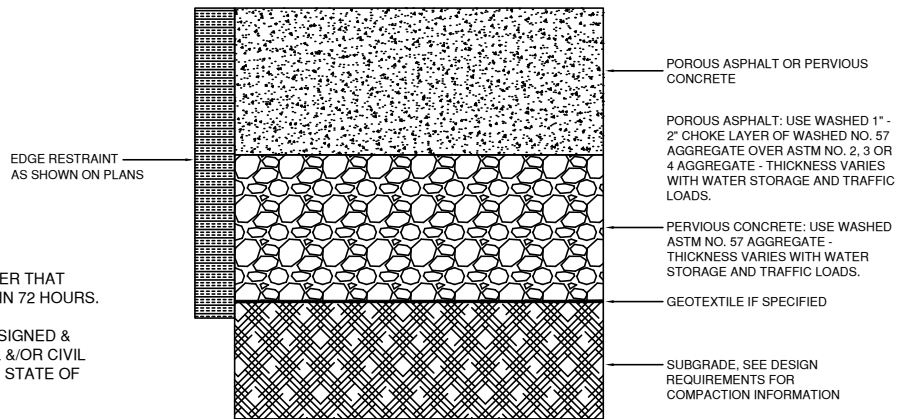
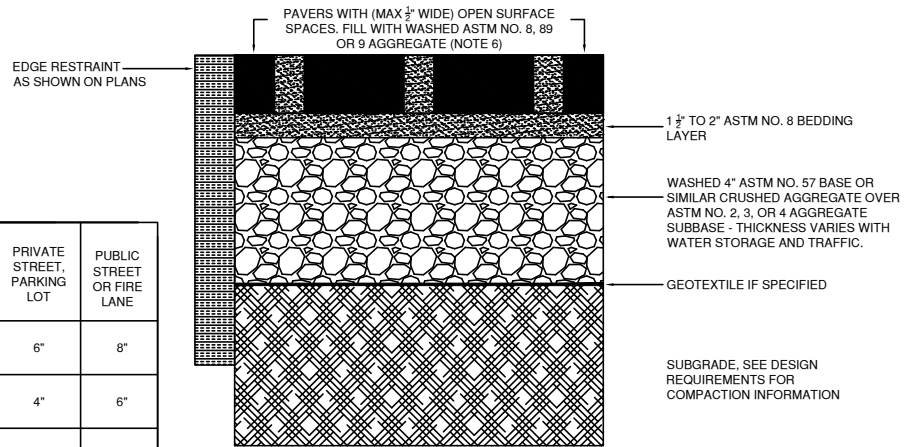

**NOTES:**

1. UNDERDRAIN TO REMOVE WATER THAT CANNOT BE INFILTRATED WITHIN 72 HOURS.
2. DESIGNS PROVIDED SHALL BE SIGNED & STAMPED BY A GEOTECHNICAL &/OR CIVIL ENGINEER REGISTERED IN THE STATE OF CALIFORNIA.
3. GEOTEXTILE USE AND SELECTION MAY BE DETERMINED BY A GEOTECHNICAL ENGINEER PER AASHTO M-288.
4. UNDERDRAIN AND ORIFICE CONFIGURATION SHALL BE BASED ON ENGINEERED DESIGN.

**LOW IMPACT DEVELOPMENT STORMWATER MANAGEMENT STANDARD DETAILS**



DEVELOPED UNDER PROP. 84 GRANT

APPROVED BY:

VERSION:  
08/31/2017

**PERVIOUS PAVEMENT**

USE WITH STANDARD SPECIFICATIONS FOR PUBLIC WORK CONSTRUCTION

STANDARD PLAN NO.

**SW-25**

SHEET 1 OF 1





**Varying slope and ponding levels:** Varying slope and ponding levels: This bioretention planting area has sloped edges. Plants in the bottom area will be inundated during storms (**Zone A**). Those planted on the sideslopes are above the level of ponding, but will experience seasonally wet conditions (**Zone B**).

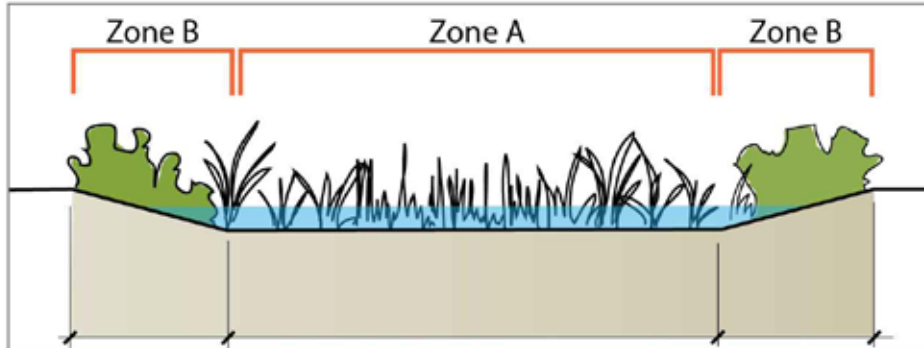

**Uniform surface grade:** This stormwater planter has a flat bottom with consistent depth of ponding across the structure. All of the plants selected for this design must be tolerant of periodic inundation (**Zone A**).

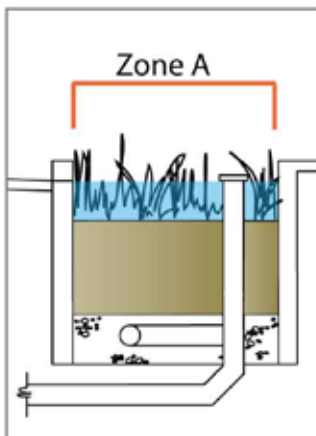

LOW IMPACT DEVELOPMENT STORMWATER MANAGEMENT STANDARD DETAILS



DEVELOPED UNDER PROP. 84 GRANT

APPROVED BY:

VERSION:

08/31/2017

PLANTING INUNDATION ZONES

USE WITH STANDARD SPECIFICATIONS FOR PUBLIC WORK CONSTRUCTION

STANDARD PLAN NO.

**SW-26**

SHEET 1 OF 4

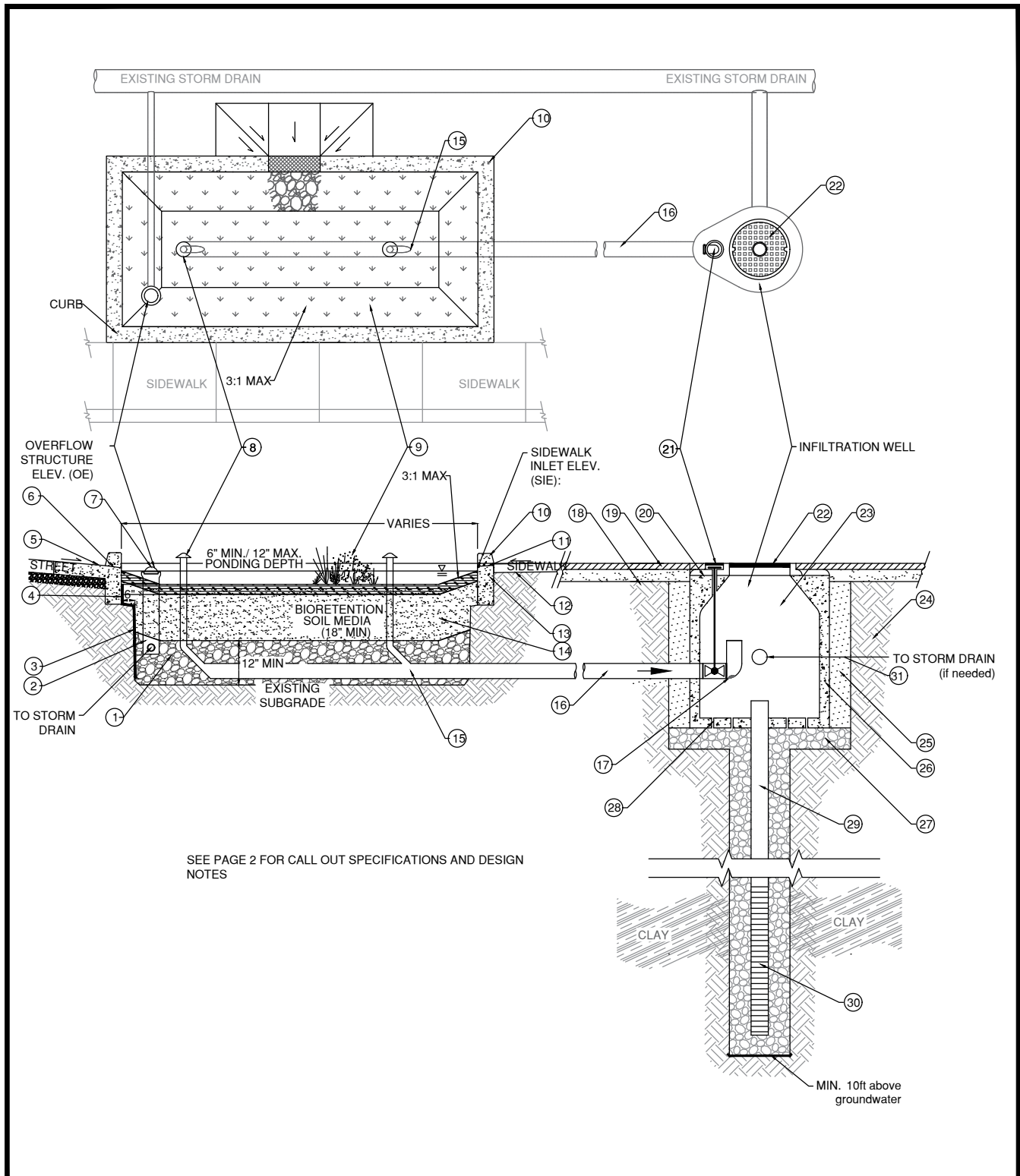

LOW IMPACT DEVELOPMENT STORMWATER MANAGEMENT STANDARD DETAILS

|   |   |  |  |
|---|---|--|--|
|   <p>DEVELOPED UNDER PROP. 84 GRANT</p> | <p>APPROVED BY:</p> <hr/> <p>VERSION:</p> <p>08/31/2017</p> | <p>DRYWELL STORMWATER BMP</p> <p>USE WITH STANDARD SPECIFICATIONS FOR PUBLIC WORK CONSTRUCTION</p> | <p>STANDARD PLAN NO.</p> <p><b>SW-27</b></p> <p>SHEET 1 OF 2</p> |
|---|---|--|--|



## SPECIFICATIONS

1. 12" DEEP OPEN GRADED WASHED STONE (TYPICALLY 3/4" TO 1-1/2" (ASTM #4 STONE) OR 1" TO 2" (ASTM #3 STONE).
2. BRIDGING LAYER(S) PER LIDI BIORETENTION TECHNICAL SPECIFICATIONS (BTS). DO NOT USE FILTER FABRIC BETWEEN BSM AND AGGREGATE. DO NOT USE FILTER FABRIC BETWEEN BIOFILTER SOIL MATERIAL (BSM) AND AGGREGATE.
3. 30 ML LINER MAY BE REQUIRED TO AVOID LATERAL INFILTRATION BELOW STREET; SUBJECT TO GEOTECHNICAL RECOMMENDATIONS.
4. MAINTAIN 6" MINIMUM BENCH OF NATIVE SOIL FOR SUPPORT OF ADJACENT SIDEWALK/ROAD (TYPICAL).
5. CURB AND GUTTER DETAIL SW-12.
6. CURB INLET DETAIL SW-17, GUTTER INLET ELEV (GIE). LOCATE ENERGY DISSIPATION COBBLE PADS AS SPECIFIED IN INLET DETAILS.
7. OVERFLOW STRUCTURE REQUIRED FOR IN-LINE SYSTEMS WITHOUT OVERFLOW BYPASS, DETAIL SW-22, SW-22A, and SW-23.
8. MAINTENANCE PIPES - 4" MIN. DIA. VERTICAL PVC PIPES CONNECTED TO UNDERDRAIN. PLACED AT START AND 3 FEET BEFORE END OF UNDERDRAIN. REQUIRES DIRECTIONAL SWEEP BEND. THREADED AND CAPPED
9. VEGETATION - PLANT SELECTION AND MULCH (OPTIONAL) PER BIORETENTION TECHNICAL SPECIFICATIONS.
10. 4" MIN. EXPOSED WALL HEIGHT
11. SIDEWALK DRAINAGE NOTCH 1" LOWER THAN SIDEWALK, SLOPED TO FACILITY
12. SEE PLANS FOR SIDEWALK RESTORATION
13. DEEP CURB DETAIL SW-13
14. BIORETENTION SOIL MEDIA (BSM). SPECIFICATION PER BIORETENTION TECHNICAL SPECIFICATIONS (BTS). SPECIFICATION SHOULD AVOID COMPOST OR OTHER MATERIAL KNOWN TO LEACH NUTRIENTS.
15. UNDERDRAIN, MIN. 4" DIA. PVC SDR 35 PERFORATED PIPE OR LARGER AS NEEDED TO CONVEY PEAK TREATED FLOWRATE WITH MINIMAL HEAD LOSS, SEE CONSTRUCTION NOTES.
16. 8" INLET PIPE OR OTHER.
17. LOW FLOW ORIFICE. (SEE DESIGN NOTE 11).
18. STABILIZED BACKFILL - TWO-SACK SLURRY MIX.
19. SIDEWALK PER MUNICIPAL STANDARDS.
20. COMPACTED BASE MATERIAL.
21. ACCESS HATCH WITH SHUT OFF VALVE SWITCH. CONNECTED TO SHUT OFF VALVE IN INLET PIPE.
22. MAINTENANCE HOLE COS TYPE 204-204 MH A OR B. 3/4" I.D. MIN OBSERVATION PORT.
23. MANHOLE CONE - MODIFIED FLAT BOTTOM.
24. EXISTING SOILS. (SEE CONSTRUCTION NOTE 4, 8).
25. COMPACTED BACKFILL
26. PRE-CAST OR INSITU CAST CONTROL VAULT (SEE DESIGN NOTE 8)
27. ROCK - WASHED, SIZED BETWEEN 3/8" AND 1-1/2"
28. PERFORATED BASE OF CONTROL VAULT
29. DRILLED SHAFT WITH 6" WELDED STEEL OR THREADED PVC CASING (SEE DESIGN NOTE 13 & CONSTRUCTION NOTE 7,8)
30. 6 - 8" O.D. WELDED WIRE STAINLESS STEEL WELL SCREEN OR THREADED PVC SLOTTED SCREEN. SCREEN LENGTH + LENGTH + SLOT WIDTH TO BE DETERMINED IN ACCORDANCE WITH LOCAL CONSTRAINTS .I.E. DISTANCE BETWEEN CLAY LAYER AND MIN. 10FT ABOVE SEASONAL HIGH GROUNDWATER LEVEL
31. PVC STORMDRAIN CONNECTOR PIPE. SAME DIAMETER AS INFLOW PIPE TO CONTROL VAULT.

## DESIGN NOTES

1. ADDITIONAL DESIGN GUIDANCE FOR BIOFILTRATION SYSTEM PROVIDED IN LIDI BIORETENTION TECHNICAL SPECIFICATIONS (BTS) DOCUMENT.
2. BOTTOM WIDTH - PROVIDE 2 FT MINIMUM FLAT BREGENALL
3. BOTTOM WITH A MAX 3:1 SLOPE FOR SURFACE FINISHING WITHIN BIOFILTRATION SYSTEM
4. IF CALTRANS CLASS 2 PERMEABLE IS NOT AVAILABLE, SUBSTITUTE CLASS 3 PERMEABLE WITH AN OVERLYING 3" DEEP LAYER OF 3/4" (NO. 4) OPEN-GRADED AGGREGATE.
5. PROVIDE SPOT ELEVATIONS AT INLETS ON CIVIL PLANS (FE, OE, GIE, SIE). SEE DETAIL SW-17.
6. EDGE CONDITION WILL VARY FOR NEW AND RETROFIT PROJECTS. CURB, WALL, AND SIDEWALK DETAILS MAY BE MODIFIED FOR PROJECT BY CIVIL AND GEOTECHNICAL ENGINEERS.
7. PROVIDE MONITORING WELL IN EACH FACILITY, PER BIORETENTION TECHNICAL SPECIFICATIONS.
8. LONGITUDINAL SLOPE 6% WITH CHECK DAMS.
9. IF CHECK DAMS ARE NEEDED, SEE CONCRETE CHECK DAM DETAIL SW-18.
10. VARIATIONS IN DRY WELL DESIGN SHOULD BE MADE TO ACCOMMODATE STORAGE VOLUME DESIGN AND TO SUIT LOCAL CONDITIONS AND CONSTRAINTS.
11. IN AREAS WITHOUT A STORMDRAIN, THE SYSTEM SHOULD ONLY BE CONSTRUCTED WHERE THE MAINTENANCE HOLE SURFACE INVERT IS ABOVE THE BIOFILTER OVERFLOW ELEVATION.
12. ALTERNATIVE VAULT LOCATIONS POSSIBLE INCLUDING WITHIN THE BIOFILTER FOOTPRINT.
13. VALVE CAN BE MOVED TO THE BIOFILTER IF DESIRED. REQUIRES STRUCTURAL SUPPORT.
14. ALTERNATIVE PRODUCTS SUCH AS VENDOR-SUPPLIED DRY WELL PRODUCTS MAY BE USED AS A SUBSTITUTE PROVIDED THAT THE ALTERNATIVE PRODUCT IS EQUAL.
15. THIS DESIGN IS LIKELY TO QUALIFY AS A CLASS V WELL SUBJECT TO REGISTRATION WITH THE USEPA.

## LOW IMPACT DEVELOPMENT STORMWATER MANAGEMENT STANDARD DETAILS

|   |                        |   |                                  |
|---|------------------------|---|----------------------------------|
|  <br>DEVELOPED UNDER PROP. 84 GRANT | APPROVED BY:           | DRYWELL STORMWATER BMP<br><br>USE WITH STANDARD SPECIFICATIONS FOR PUBLIC WORK CONSTRUCTION | STANDARD PLAN NO.                |
|   | VERSION:<br>08/31/2017 |   | <b>SW-27</b><br><br>SHEET 2 OF 2 |



**Low Impact Development Initiative (LIDI)  
Bioretention Technical Specifications (Adapted from CASQA)**

The following technical information is for use in conjunction with the complete set of bioretention area standard details developed by the LIDI for use in the Central Coast region and throughout California. Central Coast region-specific requirements are noted where applicable.

Facility Design/Dimensions

- Bioretention facilities should be sized to retain and/or treat the water quality design flow and/or volume in accordance with the stormwater permit requirements that apply to the local jurisdiction and appropriate local, countywide, and/or statewide (CASQA) guidance documents. Design parameters specified in stormwater permits will determine the surface area and storage volume required within the facility.
- Bottom width – facilities should have flat bottoms and sufficient width for ease of constructability and maintenance.
  - Provide 2’ wide minimum for facilities with side slopes and planters (facilities with vertical side walls).
- Allowable standing water duration – generally 48 to 72 hours  
 Allowable ponding time is typically associated with mosquito vector control or perceived nuisance flooding and varies by location.
- Ponding depth - Min. 6", max. 12". The depth is measured from the surface of the bioretention soil media and not adjusted for application of mulch.
- Planter depth – (from adjacent pedestrian walking surface to facility finished elevation/planting surface) is based on desired ponding plus freeboard, but also relates to planter width. Planters can be deeper if they are wider, and need to be shallower as they narrow. This is a pedestrian perception and safety issue. Some recommended width to depth guidelines are as follows (allowable depths and appropriate edge treatments may be specified by the local jurisdiction and may be determined by ADA requirements):

| PLANTER WIDTH | MAX. PLANTER DEPTH |
|---------------|--------------------|
| > 5’          | 16”                |
| 4’ – 5’       | 12”                |
| 3’ – 4’       | 10”                |
| 2’ – 3’       | 8”                 |



- Slope/grades
  - Side slope - 4:1 preferred
    - Max. 3:1 allowed with min. 12" wide shoulder (2% slope toward facility) adjacent to pedestrian use or curb.
  - Longitudinal slope – Facility should be relatively flat (i.e., maximum of 2% longitudinal slope of bottom) so that water ponds and infiltrates evenly across the facility surface.
    - If installed on a slope, facilities should be terraced and separated by check dams and weir overflows to provide flat-bottomed cells with proper storage and infiltration.
    - Installation not recommended on slopes > 8%.
  - Grades on opposite sides within a facility should be similar to optimize ponding across the entire basin/cell.

### Hard Infrastructure

- Inlet curb cut design selection should be based on application considerations:
  - Sloped sided or planter facility
  - Curb and gutter adjacent to facility or separated by pedestrian sidewalk
- Curb cut width – 12"-18" minimum, with rounded edges, depress gutter 2" at opening (see SW-14, SW-15, SW-16)
- Sidewalk edge type selection should be based on application considerations:
  - New or retrofit
  - Sloped sided or planter box
- Sidewalk wall - planter box requires 4" min. height wall adjacent to sidewalk for pedestrian safety.
- Sidewalk wall drainage notch – when sidewalk drains to planter, provide 4"-6" wide notch openings in wall, opening 1" below sidewalk, slope to facility. Space openings to convey flows.
  - Provide minimum 2" cover between notch and structural dowels in curbs/walls.
- Energy dissipation – provide aggregate or concrete splash pads at inlets per inlet details.
  - For aggregate: 6" depth, 3" – 6" rounded, washed cobble
  - For sloped sided facilities where inlet flow velocity is high, extend cobble into facility, but avoid excessive or decorative use.
- Where impermeable liner is included between facility and adjacent



infrastructure (street, parking lot), use 30 ML HDPE or PVC material, see Impermeable Liner detail.

- Check dams – provide for facilities installed on slope
  - Per check dam details SW-17 and SW-18
  - Check dams should be placed for every 4-6” of elevation change and so that the top of each dam is at least as high as the toe of the next upstream dam.
- Overflow structure – required for on-line systems without an overflow bypass
  - Per overflow structure details SW-19, SW-20
  - Connect to approved discharge point or another downstream bioretention area.
- Provide observation well in facility if required
  - Upright 6 inch rigid PVC (SDR 40 or equivalent) pipe, perforated for the section extending through the depth of the bioretention soil media (and aggregate layer if included), extending 6 inches above the top of soil elevation, with a threaded cap.
  - Locate to avoid damage from maintenance activities.

#### Facility Media (soil, aggregate, mulch)

- Aggregate layer – where an aggregate layer is included in the design (underdrain design or optional use based on project requirements, depth based on sizing calculations), specify “CalTrans Class 2 Permeable.”
  - CalTrans Class 2 Permeable does not require an aggregate filter course between the aggregate storage layer and the bioretention soil media above.
  - When CalTrans Class 2 Permeable is not available, substitute CalTrans Class 3 Permeable.
    - Class 3 Permeable requires an overlying 3” deep layer of  $\frac{3}{4}$ ” (No. 4) open graded aggregate (between Class 3 and bioretention soil media above).
  - Filter fabric - do NOT use fabric between bioretention soil media and aggregate layer
- Bioretention soil media (BSM) - use local jurisdiction approved/recommended BSM (e.g. Bay Area Stormwater Management Agencies Association (BASMAA) Regional Biotreatment Soil Specification (revised January 29, 2016)<sup>1</sup>.

1

[http://www.waterboards.ca.gov/sanfranciscobay/water\\_issues/programs/stormwater/MRP/provisionC.3/Revised\\_%20Biotreatment%](http://www.waterboards.ca.gov/sanfranciscobay/water_issues/programs/stormwater/MRP/provisionC.3/Revised_%20Biotreatment%20Soil%20Specification.pdf)



- Using a performance specification for alternative bioretention soil mix is not recommended (but may be allowed by the local jurisdiction).
- A pre-mixed bioretention soil media is preferable to mixing soil on-site.
- BSM depth – 18” minimum depth; 24” recommended, or as required by the local jurisdiction. 24” depth required in the Central Coast Region for facilities with underdrains.
  - Where trees are specified, increase BSM depth in tree planting locations, per arborist’s or landscape architects direction, or allow trees access to sufficient volume of native soil.
    - Tree planting in bioretention - see BASMAA Literature Review - Bioretention Design for Tree Health (September 15, 2016)<sup>2</sup>
- Bioretention soil media placement and compaction – place BSM in 6” lifts. Compact each lift with a landscape roller or by lightly wetting. Allow BSM to dry overnight before planting.
- Mulch depth – 2” – 3” (3” recommended and required by State Model Water Efficiency Landscape Ordinance)
  - Do not apply mulch in ponding zone just prior to or during rainy season.
  - When mulch is used, excavation must allow for specified bioretention soil depth to achieve finished elevations as shown on civil plans
- Mulch type - when used in ponding zone, must be aged, stabilized, non-floating mulch, such as a specified composted wood mulch. Gravel mulch may also be used when high flow velocities through the system are expected.

#### Landscape (planting and irrigation)

- Irrigation - Provide irrigation for plant establishment (2-3 years), and supplemental irrigation during periods of prolonged drought.
  - Provide separate zone for connection to water supply
- Planting - see LIDI plant guidance for bioretention areas technical assistance memo (TAM) or use bioretention plant list in other local or countywide guidance document.
  - Landscape Architects who have not previously designed bioretention systems should use plants from the LIDI TAM or other approved plant list. Landscape Architects with experience designing for bioretention may use additional plant species consistent with the above lists and

---

<sup>2</sup>20\_Soil.pdf  
[www.basmaa.org](http://www.basmaa.org)



appropriate for the facility design and local conditions.

- Do not locate plants at inlets. Consider mature growth to determine planting layout and avoid future blockage of inlets by plants.
- Trees located on slopes should be 5' minimum from inlets to avoid erosion of soil at root ball.

### Underdrain Design

- Aggregate layer depth – 12" minimum depth.
- Underdrain – use 4" diameter, PVC SDR 35 perforated pipe.
  - Install underdrain with holes facing down.
  - Underdrain discharge elevation should be near top of aggregate layer if facility is allowed to infiltrate into native soil.
  - Underdrain slope may be flat or have a slight slope.
  - Connect underdrain to approved discharge point.
  - Provide capped, threaded PVC cleanout for underdrain, 4" min. dia. with sweep bend.
  - Do NOT wrap underdrain with filter fabric.





**ATTACHMENT J:**  
J2: POST-CONSTRUCTION BMP DESIGN  
GUIDANCE

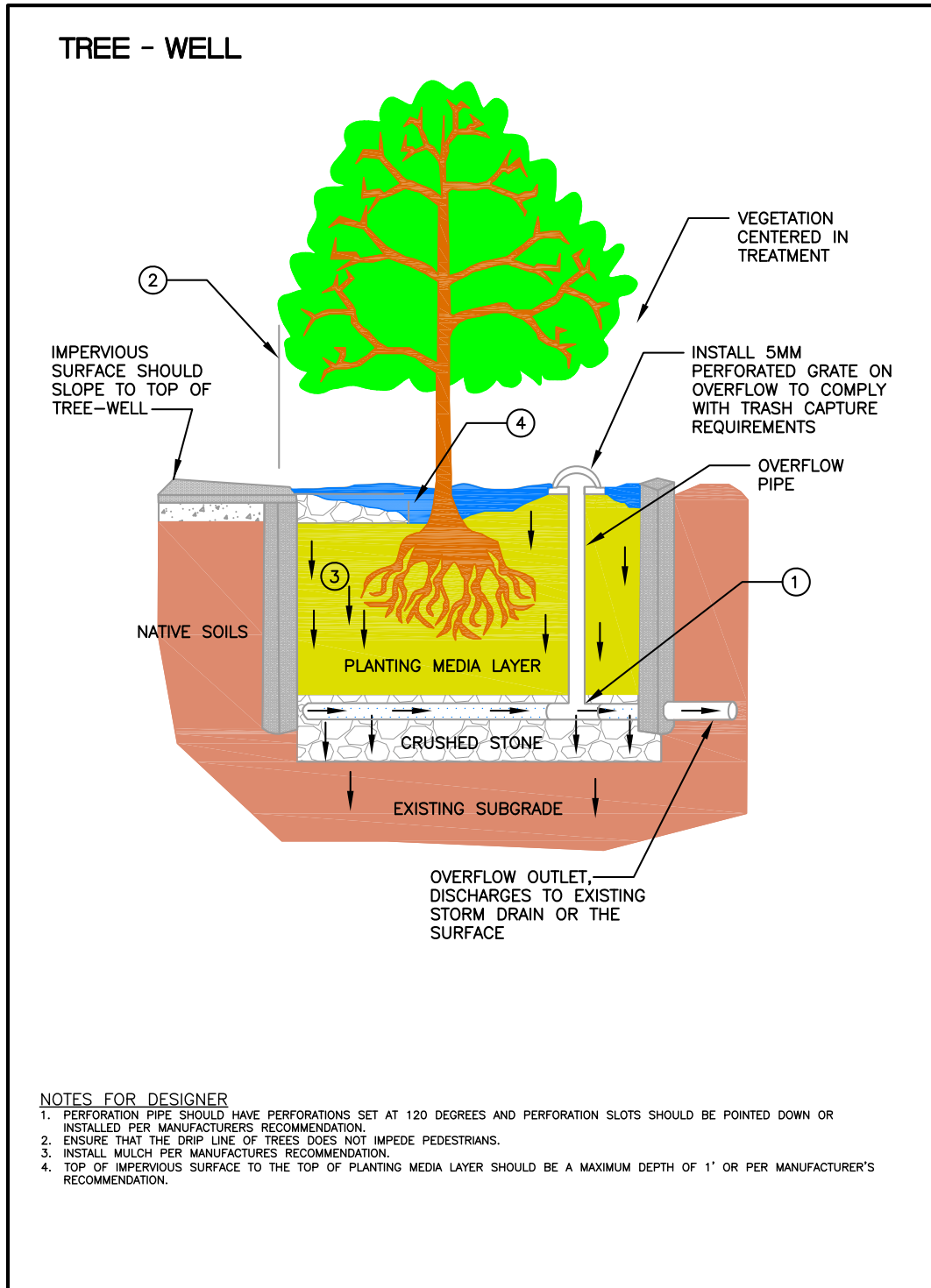



## SELF - RETAINING AREAS

### NOTES FOR DESIGNERS:

1. LANDSCAPED SELF-RETAINING AREAS ARE DESIGNED AS CONCAVE AREAS THAT WILL RETAIN THE FIRST ONE-INCH OF RAINFALL WITHOUT PRODUCING ANY RUNOFF (ALTHOUGH SELF-RETAINING AREAS DO NOT NEED TO BE HYDRAULICALLY SIZED LIKE A TREATMENT MEASURE, ONE-INCH DEPTH ROUGHLY CORRESPONDS TO THE MS4 NUMERIC VOLUME-BASED AND FLOW-BASED SIZING CRITERIA).
2. PERVIOUS PAVING OR ARTIFICIAL TURF DESIGNED AS A SELF-RETAINING AREA MUST PROVIDE ADEQUATE STORAGE IN THE VOID SPACE OF THE GRAVEL BASE LAYER TO ACCOMMODATE THE VOLUME OF RUNOFF SPECIFIED IN THE MS4 PERMIT FOR BOTH THE AREA OF PERVIOUS PAVING AND THE IMPERVIOUS SURFACES THAT CONTRIBUTE RUNOFF. THE AREA MUST ALLOW FOR INFILTRATION OF WATER AND NOT BE LINED WITH IMPERVIOUS MATERIALS OR CONSTRUCTED OVER AN IMPERVIOUS BARRIER.
3. RUNOFF MAY ENTER THE SELF-RETAINING AREA AS SHEET FLOW, OR IT MAY BE PIPED FROM A ROOF OR AREA OF IMPERVIOUS PAVEMENT (I.E. DOWNSPOUT DISCONNECTION).
4. THE SELF-RETAINING AREA MUST DRAIN COMPLETELY WITHIN 5 DAYS UNDER SATURATED CONDITIONS.
5. A **MAXIMUM 2:1 RATIO OF IMPERVIOUS AREA TO THE RECEIVING PERVIOUS AREA** IS ACCEPTABLE, WHERE THE PERVIOUS AREA CAN POND UP TO 3 INCHES IN DEPTH (I.E., 1 INCH OF DEPTH ON THE PERVIOUS AREA PLUS 1 INCH FROM EACH OF THE 2 UNITS OF IMPERVIOUS AREA).
6. DRAINAGE FROM SELF-RETAINING AREAS (FOR AMOUNTS OF RUNOFF GREATER THAN THE FIRST ONE-INCH) MUST FLOW TO OFF-SITE STREETS OR STORM DRAINS WITHOUT FLOWING ONTO PAVED AREAS WITHIN THE SITE.
7. IF OVERFLOW DRAINS OR INLETS TO THE STORM DRAIN SYSTEM ARE INSTALLED WITHIN A LANDSCAPED SELF-RETAINING AREA, SET THEM AT A MAXIMUM ELEVATION OF 3 INCHES ABOVE THE LOW POINT TO ALLOW PONDING. THE OVERFLOW DRAIN, OR STORM DRAIN INLET ELEVATION, SHOULD BE HIGH ENOUGH TO ALLOW PONDING THROUGHOUT THE ENTIRE SURFACE OF THE SELF-RETAINING AREA.
8. ANY IMPERVIOUS PAVEMENT WITHIN THE SELF-RETAINING AREA (E.G., A SIDEWALK THROUGH A LANDSCAPED AREA) CANNOT EXCEED 5 PERCENT OF THE TOTAL SELF-RETAINING AREA.
9. AMENDED SOILS, VEGETATION, AND IRRIGATION IN THE SELF-RETAINING AREA MAY BE NEEDED TO MAINTAIN SOIL STABILITY AND PERMEABILITY. HOWEVER, SPECIAL BIOTREATMENT SOILS ARE NOT REQUIRED.
10. SELF-RETAINING AREAS SHOULD BE PROTECTED FROM CONSTRUCTION TRAFFIC AND COMPACTION.
11. ENERGY DISSIPATOR: INSTALL ROCK WITH FILTER FABRIC BENEATH IT (OR EQUIVALENT) AT ALL OPENINGS TO THE PERVIOUS AREA THAT RECEIVE CONCENTRATED FLOWS. ROCK SHOULD EXTEND PAST OPENING.

**EXAMPLE 1: SHEET FLOW TO SELF - RETAINING AREA**

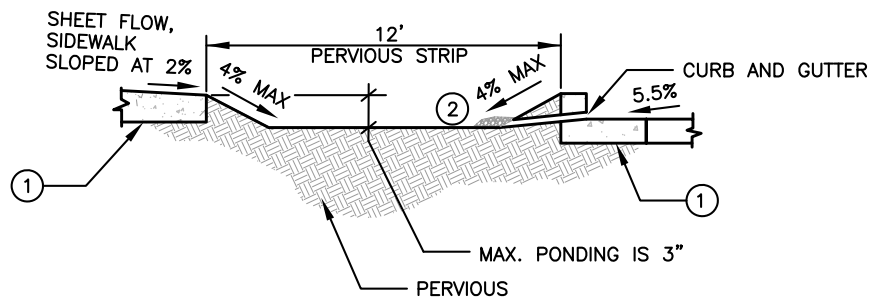
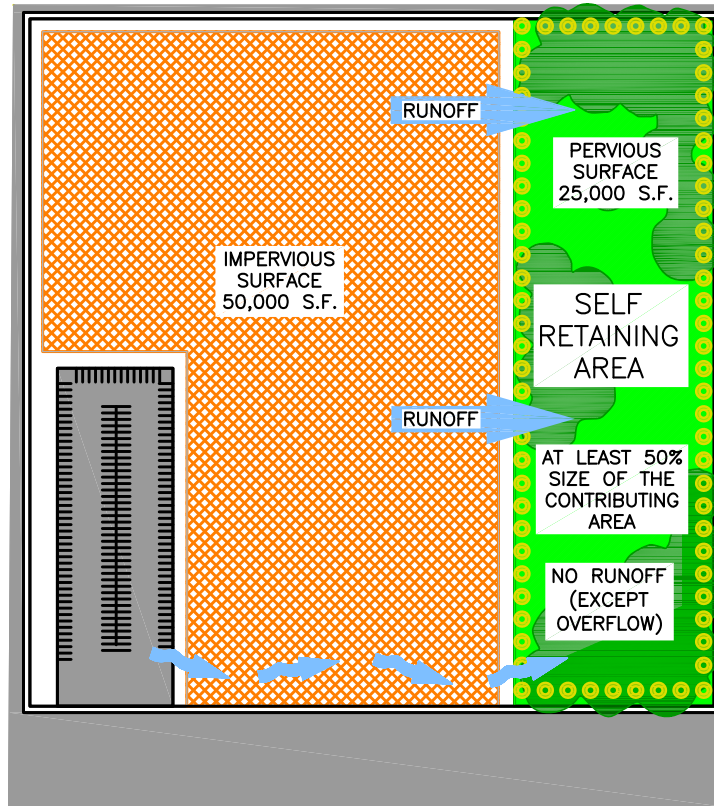

**NOTES FOR DESIGNER**

1. MAXIMUM 2:1 RATIO OF CONTRIBUTING IMPERVIOUS AREA TO THE RECEIVING PERVIOUS AREA.
2. DISSIPATION BLOCK OR FABRIC WITH ROCKS.

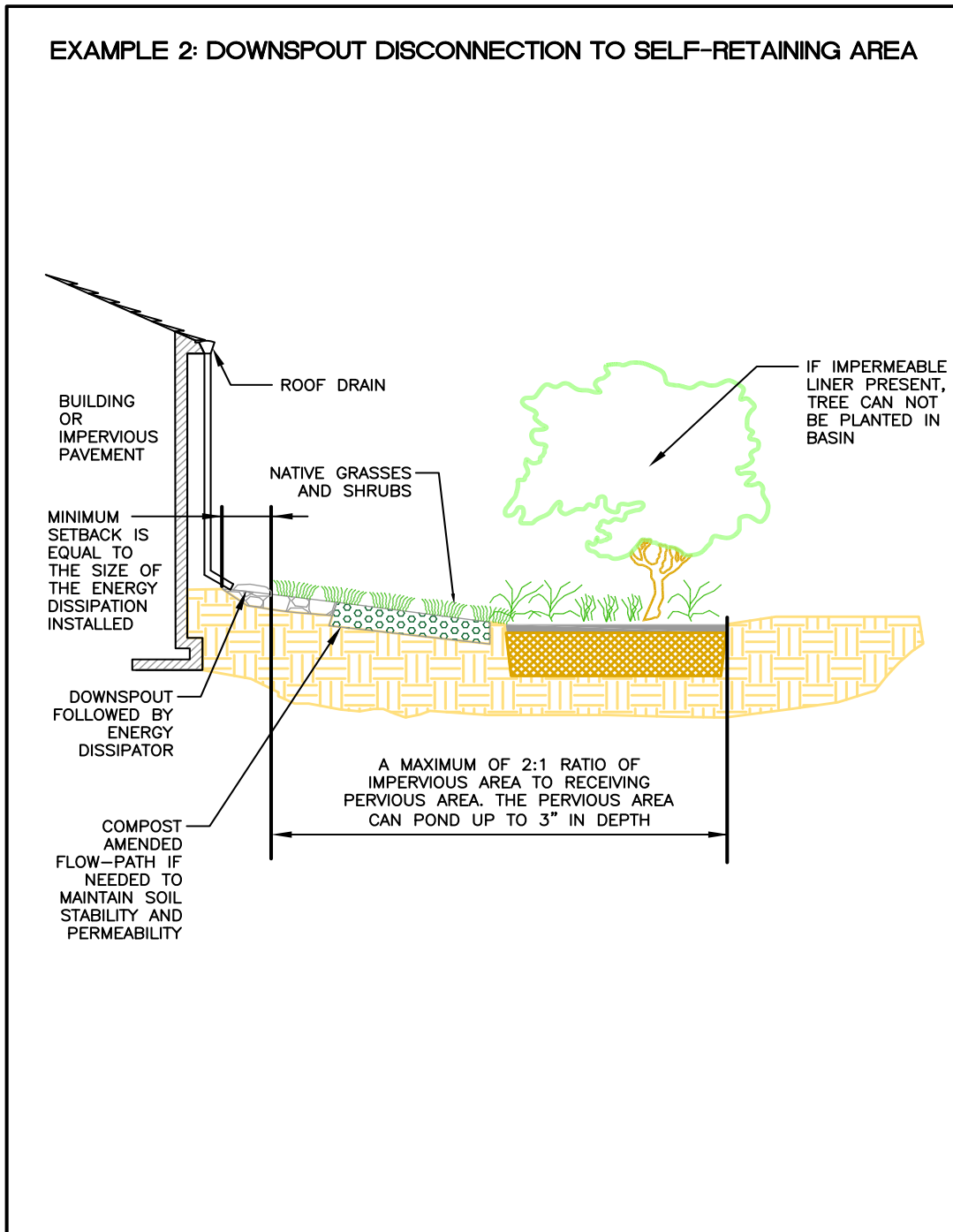

**EXAMPLE 3: VEGETATED SWALE**

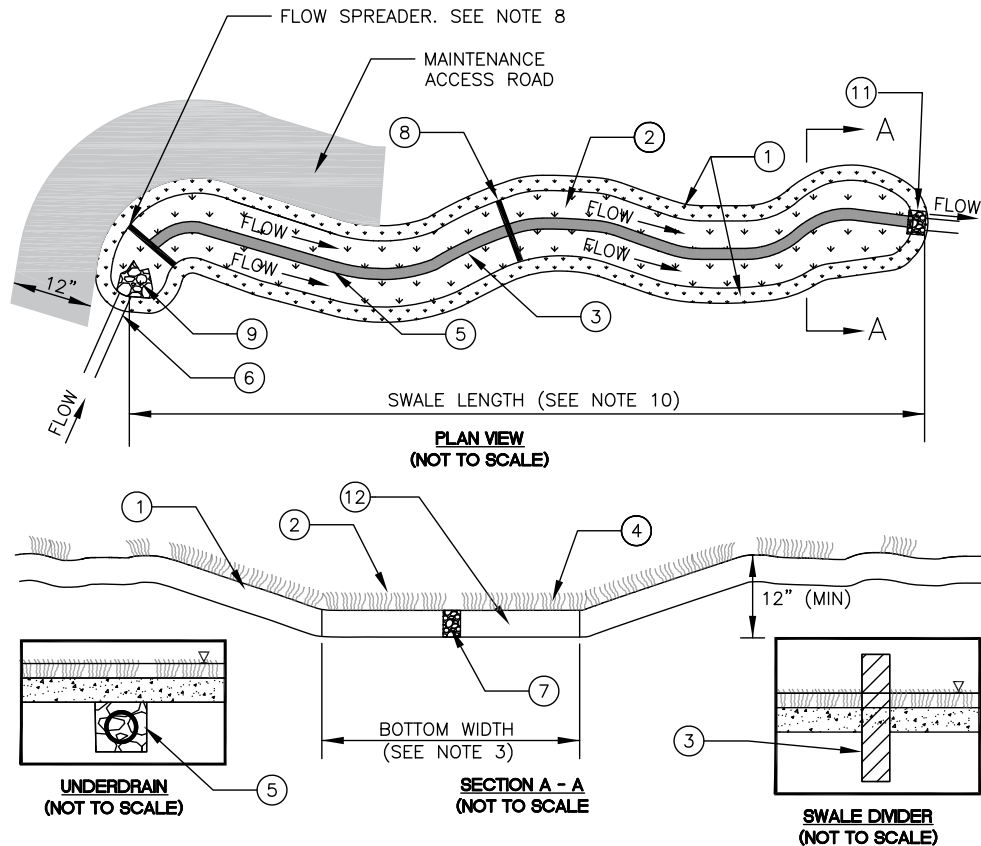

**NOTES FOR DESIGNER**

1. VEGETATED SIDE SLOPES AT 2H:1V MAX. SLOPE. MOWED TURF SWALES AT 3H:1V MAX.
2. GRASS HEIGHT 4"–6" PLANTS: SEE VTA'S LANDSCAPE CRITERIA MANUAL. DO NOT INSTALL TREES IF LINER IS PRESENT.
3. SWALE DIVIDER REQUIRED FOR BOTTOM WIDTHS > 10'. MINIMUM REQUIRED BOTTOM WIDTH IS 2" EXCLUDING WIDTH OF LOW FLOW CHANNEL. MAXIMUM BOTTOM WIDTH WITH DIVIDER IS 16'.
4. DEPTH OF FLOW FOR WATER QUALITY TREATMENT MUST NOT EXCEED 2/3 OF THE GRASS HEIGHT AND NOT GREATER THAN 4" (INFREQUENTLY MOWED) OR 2" (FREQUENTLY MOWED).
5. 6" PERFORATED UNDERDRAIN IN 9" DEEP COURSE AGGREGATE BED CONNECTED TO STORM DRAIN REQUIRED FOR SLOPES <1.5%. PERFORATION PIPE SHOULD HAVE PERFORATIONS SET AT 120 DEGREES AND PERFORATION SLOTS SHOULD BE POINTED DOWN.
6. INLET PIPE WITH INLET PROTECTION.
7. IF NO UNDERDRAIN, LOW FLOW DRAIN SHALL EXTEND ENTIRE LENGTH OF SWALE AND SHALL HAVE A DEPTH OF 6" MINIMUM AND WIDTH NO MORE THAN 5% SWALE BOTTOM WIDTH. IF USED, ANCHORED PLATE FLOW SPREADER SHALL HAVE V-NOTCHES (MAXIMUM TOP WIDTH 5% OF SWALE WIDTH) OR HOLES TO ALLOW PREFERENTIAL EXIT OF LOW FLOWS.
8. INSTALL CHECK DAMS OR GRADE CONTROL STRUCTURES FOR SLOPES >6% AT 50' MAXIMUM SPACING TO ACHIEVE MAXIMUM EFFECTIVE LONGITUDINAL SLOPE OF 6% SPREADERS MUST BE PROVIDED AT INLET AND AT BASE OF EACH CHECK DAM.
9. INSTALL ENERGY DISSIPATOR AT THE INLET. INSTALL ROCK WITH FILTER FABRIC BENEATH IT (OR EQUIVALENT) AT ALL OPENINGS TO THE BASIN. ROCK SHOULD EXTEND PAST OPENING.
10. SWALE LENGTH SHALL BE 100' OR LENGTH REQUIRED TO PROVIDE 10 MINUTES RESIDENCE TIME, WHICH EVER IS GREATER. MAXIMUM 2:1 RATIO OF CONTRIBUTING IMPERVIOUS AREA TO THE RECEIVING PERVIOUS AREA.
11. INSTALL APPROPRIATE OUTLET STRUCTURE TO ACCOMMODATE LOW FLOW CHANNEL AND/OR UNDERDRAIN, IF PRESENT.
12. AMEND SOILS WITH 2" COMPOST TILLED INTO 6" OF NATIVE SOIL UNLESS SOIL ORGANIC CONTENT IS >10%.

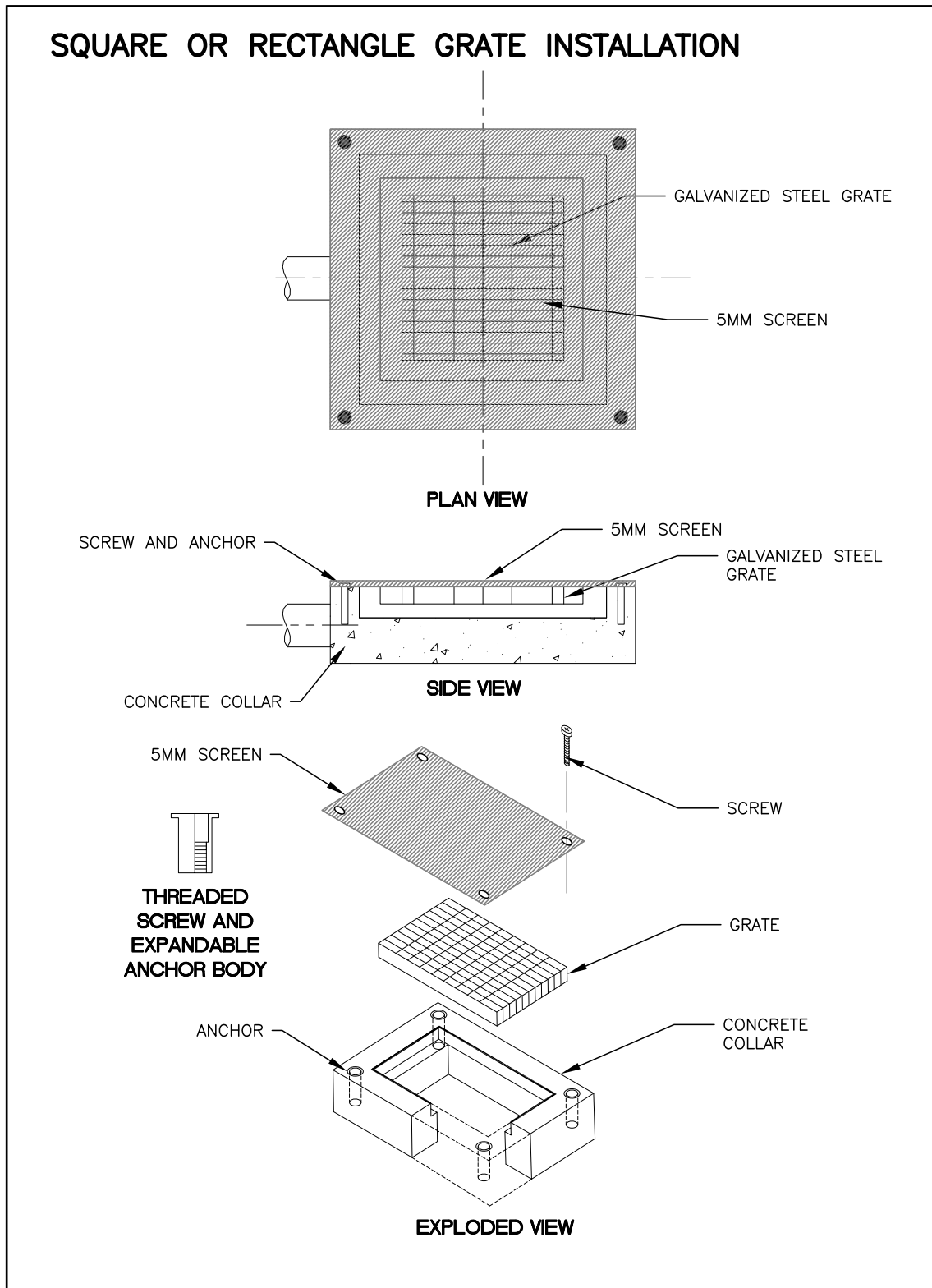

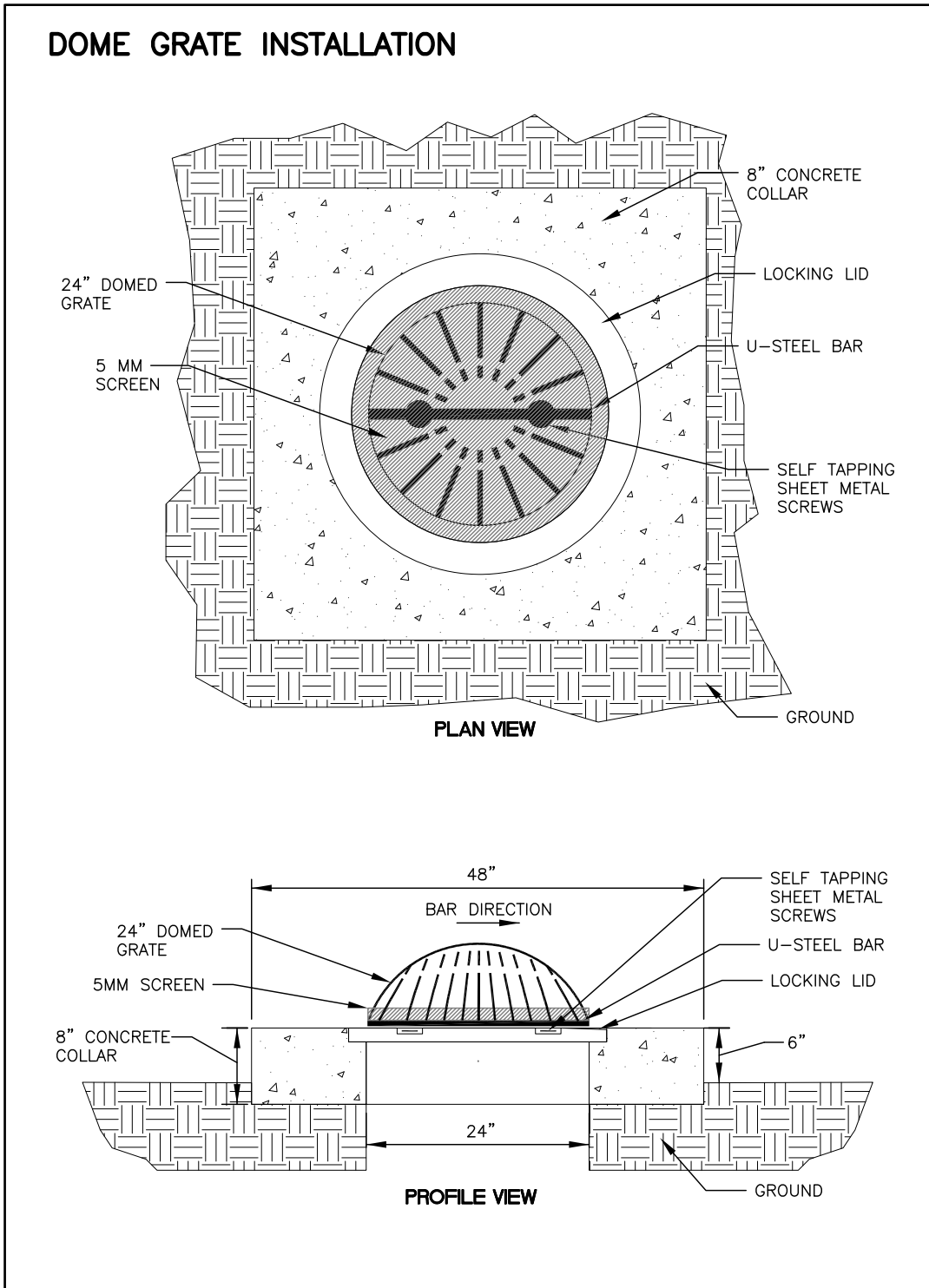





**ATTACHMENT K:**  
BIORETENTION FACILITY SAFETY SIGNAGE



# BIORETENTION—DO NOT CROSS ADVISORY SIGN

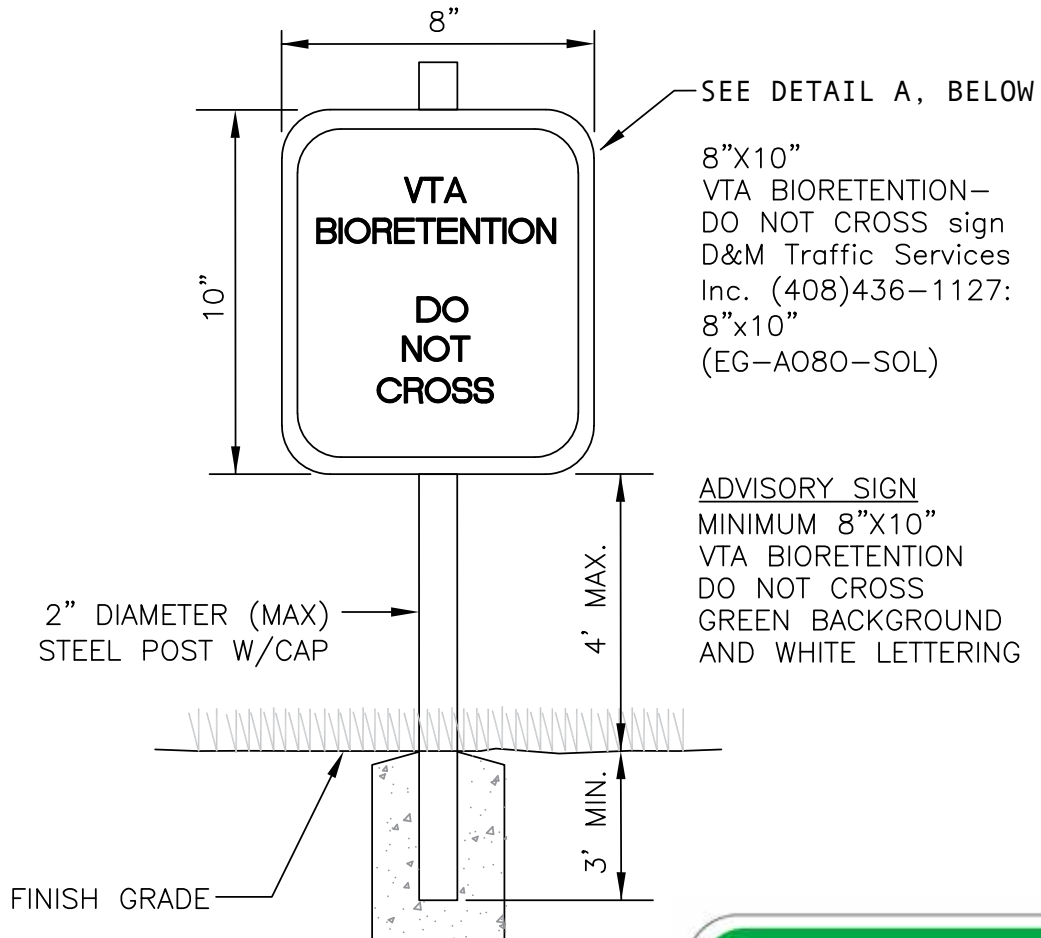

8"x10"  
VTA BIORETENTION—  
DO NOT CROSS sign  
D&M Traffic Services  
Inc. (408)436-1127;  
8"x10"  
(EG-A080-SOL)

ADVISORY SIGN  
MINIMUM 8"x10"  
VTA BIORETENTION  
DO NOT CROSS  
GREEN BACKGROUND  
AND WHITE LETTERING

Detail A





**ATTACHMENT L:**  
O&M PLAN



**ATTACHMENT L:**

L1: TEMPLATE O&M MANUAL



## Post-Construction BMP Operations and Maintenance Guidelines



## Table of Contents

|   |    |
|---|----|
| INTRODUCTION.....   | 3  |
| STORMWATER FACILITY OPERATION AND MAINTENANCE RESPONSIBILITY.....                     | 3  |
| RECORDS.....  | 3  |
| SAFETY.....   | 3  |
| TOOLS.....  | 4  |
| MAINTENANCE OF SOURCE CONTROLS.....   | 4  |
| MAINTENANCE OF SITE DESIGN RUNOFF REDUCTION MEASURES.....                             | 4  |
| Runoff Reduction Measure Table.....   | 5  |
| MAINTENANCE OF STORMWATER TREATMENT MEASURES (IF APPLICABLE).....                     | 5  |
| Stormwater Treatment Measures Table.....  | 5  |
| Maintenance of Bioretention Facilities and Flow-Through Planters (If Applicable)..... | 5  |
| Bioretention Facility Maintenance Table.....  | 6  |
| Maintenance of Tree-Well Filters (If Applicable).....                                 | 9  |
| Tree-Well Maintenance Visit Summary.....  | 9  |
| Tree-Well Manufacturer’s Cut-Sheets.....  | 9  |
| Maintenance of In-Vault Media Filters (If Applicable).....                            | 9  |
| In-Vault Media Filter Manufacturer’s Cut-Sheets.....                                  | 10 |
| Maintenance of Trash Control Measures (If Applicable).....                            | 10 |
| Trash Control Device Manufacturer’s Cut-Sheets.....                                   | 10 |
| APPENDIX A: FACILITIES MAP (SAMPLE).....  | 11 |
| APPENDIX B: BIORETENTION INSPECTION FORM (SAMPLE).....                                | 12 |
| APPENDIX C: VTA APPROVED PESTICIDES (SAMPLE).....                                     | 17 |



## Introduction

Designer to include Project Title, project location and short project description. Include description of the type of Post-Construction Best Management Practices (BMPs) that will require on-going maintenance.

## Stormwater Facility Operation and Maintenance Responsibility

Designer to include language describing the responsibilities related to the Operation and Maintenance (O&M) of the project's Post-Construction Best Management Practices (BMPs). If VTA will be entering into an O&M agreement, state the responsibilities of each entity involved.

**Sample Language:** *VTA will enter into Operation and Maintenance (O&M) Agreements with the City of San Jose and the City of Milpitas to each maintain the BMPs that treat runoff from their respective right-of-way. Maps showing the locations of VTA and City BMPs including the two station areas can be found in Appendix A. The VTA O&M maintenance will be performed by in-house VTA staff or contractors at VTA's discretion.*

## Records

Designer to include language describing the responsible party for O&M inspections, as required by the Phase II Municipal Separate Storm Sewer System (MS4) Permit.

**Sample Language:** *The VTA O&M inspections will be performed by in-house VTA staff or contractors at VTA's discretion. Inspection and Maintenance checklists will be completed per in-house standard or contract requirements for each BMP. These will be submitted to the following address:*

*VTA Environmental Programs  
Attn: Name – VTA MS4 Stormwater Program Project Manager  
3331 North First Street  
San Jose, CA 95134*

*Oversight inspections will be performed by VTA Environmental Programs as part of the Municipal Stormwater (MS4) permit requirements. A sample inspection form is shown in **Appendix B**.*

## Safety

Designer to include language describing the safety concerns of related maintenance activity. Use of maintenance equipment shall be according to the manufacturer's procedures and instructions and according to VTA and Cal OSHA requirements.

**Sample Language:**

### General Safety Guidelines

- *Set up a safety perimeter and be aware of passing pedestrians, bicycles, and vehicles.*
- *Do not stand in the street when performing maintenance activities unless traffic control has safely blocked a lane.*



- *Make yourself visible. Wear bright colored clothing and a safety vest. Ensure safety color does not impede with current VTA light rail ROW safety requirements if maintenance is occurring near light rail ROW.*
- *Wear hard hats (as required), protective clothing, thick gloves, and sturdy shoes.*
- *Be aware when cutting plants and branches overhead or when working on an active construction site.*
- *Wear eye and ear protection.*
- *Be aware of broken glass, sharp objects, and other hazards.*
- *Be aware of needles and other biohazards. Use grabbers and gloves to remove needles and dispose of them properly.*
- *Be aware of loose material, standing water, tripping hazards, uneven ground, and other obstructions.*
- *Don't leave your tools unattended. Keep them out of the street and off the sidewalk so they don't pose a hazard to others.*
- *Perform maintenance on your facility during daylight hours and avoid peak traffic times.*

## Tools

Designer to include language describing the tools and equipment necessary to complete described maintenance activities.

### Sample Language:

*Ideal tools include: camera, tape measure, edging Spade, trash bags, work gloves, plant and weed photo ID sheet, tarp/buckets/trash cans (to remove leaf litter/debris), push broom, wheelbarrow, hand trowel, rake, hoe, manhole cover hook or lifter (for opening grates), flat shovel, wrenches and other tools required to unbolt manhole cover and grate locks, hedge shears and loppers, hand weeding tools, and hori-hori. Appropriate Personal Protective Equipment (PPE) should be used in accordance with local or company procedures. This may include impervious gloves where the type of trash is unknown, high visibility clothing, safety hats and shoes, and barricades when working near traffic. Additional mulch should be available as replenishment/replacement of mulch may be necessary. To maintain Tree-Wells, a T-Bar or crowbar should be used for moving the tree grates (up to 170 lbs. ea.).*

## Maintenance of Source Controls

Designer to include language describing the O&M related to the project's Source Control BMPs. Designer may refer reader to **Attachment D2** of the VTA Stormwater and Landscaping Design Criteria Manual, which includes O&M language regarding Source Controls.

## Maintenance of Site Design Runoff Reduction Measures

Designer to include language describing the O&M related to the project's Runoff Reduction Measures.

**Sample Language:** *\*Note if extensive measures and related maintenance are incorporated, designer may want to include table as an Appendix.*





### Runoff Reduction Measure Table

| Runoff Reduction Measures and Maintenance (Example) |                                       |   |
|---|---------------------------------------|---|
| Runoff Reduction Measure                            | Location                              | Operations & Maintenance  |
| Tree Planting                                       | 50 ft NW of Great Mall Transit Center | Inspect irrigation system monthly from June- Oct. for first 3 years of establishment. Inspect tree health quarterly and prune as needed.  |
| Permeable Pavement                                  | Parking Lot at Milpitas Station       | Inspect pavement monthly to ensure it is clean of debris and sediments and de-waters between storms. Keep the pervious pavement surface free of sediment by blowing, sweeping or vacuuming as needed. Annually Inspect the pervious pavement surface for deterioration or spalling. |

### Maintenance of Stormwater Treatment Measures (If Applicable)

Designer to include language describing the types of Stormwater Treatment Measures implemented in the project.

**Sample Language:** \*Note if extensive measures and related maintenance are incorporated, designer may want to include table as an Appendix.

### Stormwater Treatment Measures Table

| Stormwater Treatment Measures- Index (Example)                 |                          |           |            |
|--|--------------------------|-----------|------------|
| Location   | Type of Treatment        | VTA BMP#: | Map#:      |
| South of 237, Industrial Rd (STA 289+70 to 296+68, on exhibit) | Bioretention Basin       | ID- BR-01 | Exhibit 5c |
| Piper Drive (STA 359+70 to 364+00)                             | Bioretention Basin       | PR-BR-02  | Exhibit 5d |
| Series of basins along the Montague Bus entrance               | Bioretention Basin       | MS-BR-03  | Exhibit 4  |
| North West Basin in the Bus Circle                             | Bioretention Basin       | MS-BR-04  | Exhibit 4  |
| Milpitas Station Park and Ride (North)                         | Flow-Through Planter     | MS-FP-01  | Exhibit 4  |
| Milpitas Station Park and Ride (Middle)                        | Filtterra® Tree Well Box | MS-TW-02  | Exhibit 4  |
| Milpitas Station Park and Ride (South)                         | Filtterra® Tree Well Box | MS-TW-03  | Exhibit 4  |

### Maintenance of Bioretention Facilities and Flow-Through Planters (If Applicable)

Designer to include language describing the O&M activities related to the bioretention basins installed.

**Sample Language:** Bioretention facilities remove pollutants by filtering runoff slowly through an active layer of soil media. Dissipation rock placed at the inlets helps to prevent erosion of the mulch at the bioretention facilities. In addition, the media is held together by plant roots which help to biologically remediate some of the pollutants. To ensure continued effectiveness, regular maintenance is needed and consists of the following:



- a. *Inspect the dissipation rock area at the inlets for channels, exposed soils, or other evidence of erosion. Clear any obstructions such as trash or debris and remove any accumulation of foreign sediment. Examine dissipation rock and replenish if necessary.*
  - i. *If the inlet is not a standard street drain inlet or a concrete structure, then inspect the transition area (from the paved treated area to the basin) for erosion.*
  - ii. *Inspect side slopes for evidence of instability or erosion and correct as necessary.*
- b. *Observe soil at the bottom of the bio-retention facilities for uniform percolation throughout. If portions of the planter do not drain within 24-72 hours after a storm event, the soil should be tilled and replanted.*
- c. *Confirm that check dams and flow spreaders are in place and level and that channelization within the bioretention facility is effectively prevented.*
- d. *Examine the vegetation to ensure that it is healthy and dense enough to provide filtering and to protect soils from erosion.*
- e. *Replenish mulch as necessary, remove accumulated leaves, trash and debris, prune shrubs or trees, and mow turf areas. When mowing, remove no more than 1/3 of the grass height. Confirm that irrigation is adequate and not excessive. Replace dead plants and remove noxious and invasive weeds.*
- f. *Abate any potential vectors by filling holes in the ground in and around the bioretention facility and by insuring that there are no areas where water stands longer than 24-72 hours following a storm. If mosquito larvae are present and persistent, contact the Santa Clara County Vector Control for information and advice. Any mosquito larvicides should be applied only when absolutely necessary and only by a licensed individual or contractor.*

### Bioretention Facility Maintenance Table

Designer to include a Table or equivalent that effectively details the frequencies associated to each Bioretention Facility maintenance activity.

**Sample Language:** \*Note if extensive measures and related maintenance are incorporated, designer may want to include table as an Appendix.

| Bioretention Maintenance |  |   |
|--------------------------|--|---|
| Frequency                | Observation  | Maintenance Activity  |
| Yearly                   | <i>Inspect the bioretention facility mulch and media elevations.</i> | <i>If mulch has floated to one side or media elevation is too low, adjust the elevations and re-spread the media.</i> |
|                          | <i>Inspect the elevation of the dissipation rock.</i>                | <i>If the dissipation rock is spread out or sunk into the media, rearrange in front of the</i>                        |



*solutions that move you*

|  |   |   |
|--|---|---|
|  |   | <i>inlet or transition area between the paved area and the facility.</i>  |
|  | <i>Inspect the growth of trees and look for trunk pitch.</i>  | <i>If tree is leaning, check the support pole connections, remove any large branches to offset weight, or replant if the pitch is too great to correct.</i>   |
| <b>Monthly</b>   | <i>Inspect the bioretention facility for litter, debris, leaves, dead vegetation and anything else that might interfere with flow, filtration or growth of the plants.</i>  | <i>Remove all litter, debris, leaves, dead vegetation, etc.</i><br><br><i>Replace dead vegetation as appropriate.</i>   |
|  | <i>Inspect for growth of invasive plants.</i>   | <i>Remove any invasive plants, weeds or shrubs by hand in the basin.</i><br><i>Do not apply herbicides or pesticide within the basin area, as they are a direct MS4 connection.</i><br><br><i>Spray minimum amount necessary to control pests near the basin. If pesticides must be used, then pesticide application is to be performed by a licensed professional pest control contractor trained in Integrated Pest Management (IPM) techniques (see list of VTA approved pesticides in <b>Appendix C</b>.)</i> |
|  | <i>Inspect the condition of plantings. Plantings must be maintained in a healthy condition without use of conventional fertilizers or pesticides. Grass must be of sufficient density and health to provide filtration and to protect from erosion.</i><br><br><i>Inspect the condition of other vegetation found in the bioretention facility. Vegetation must be of sufficient density and health to provide filtration and protect from erosion.</i> | <i>Reseed bare spots and mow as necessary.</i>  |
| <b>Before each rainy season</b><br><br>(early October or prior to significant storm) | <i>Look for any obstructions that will prevent water from flowing into the bioretention facility such as: trash/debris and vegetation.</i>  | <i>Remove obstructions, clean up litter and maintain vegetation.</i>  |
|  | <i>Inspect bioretention facilities. Look for gullies, washouts, evidence of uncontrolled surface water flow or any other evidence of erosion in the bioretention facilities.</i>  | <i>Replacement soil to be placed by hand tools only and avoid compaction. Any basin compaction should be due to watering only.</i>  |
|  | <i>Determine whether the bioretention facility is draining correctly (i.e. drains in less than 24-72 hours after a storm event). Inspect</i>  | <i>Determine the cause of poor drainage (i.e. siltation of engineered soil mix, blocked</i>   |



|  |   |   |
|--|---|---|
|  | <i>adjacent infrastructure, such as retaining walls, curbs and pavement for signs of failure caused by water intrusion into the surrounding soil. This is a sign of poor drainage from the bioretention facility.</i>   | <i>subdrains, blocked catch basin, blocked storm drain) and repair.</i>   |
|  | <i>Inspect each subdrain where it enters the catch basin to see whether the subdrain pipe is dry or is clogged. Ensure that the subdrain is flowing by testing with water from the cleanout end.</i>  | <i>If water does not flow through the subdrain, rod or flush the line to ensure flow.</i>   |
|  | <i>Inspect all subdrain cleanouts. Ensure that all cleanout caps are present. Look for obstructions, debris, trash, leaves, vegetation, etc., growing inside the subdrain or covering the cleanout.</i>   | <i>Remove any obstructions by hand (if near the cleanout entrance) or by flushing (with pressurized water) if too far down the pipe. Replace missing caps and secure to prevent unauthorized removal or accidental displacement.</i>  |
|  | <i>Inspect the entire storm drain system from the upstream end to the outfall, including all catch basins. Observe the flow of water. Any evidence of ponding in the catch basins may indicate a blockage or high groundwater.</i>  | <i>Find and remove any obstructions. Flushing (with pressurized water) may be necessary.</i>  |
|  | <i>Inspect all catch basins. Look for obstructions, vegetation, debris, litter, sediment, etc. blocking the catch basins.</i>   | <i>Remove obstructions and clean drain inlets and catch basins.</i>   |
| <b>After the first heavy rain</b><br>(a rain event more than 0.5")     | <i>Determine whether the bioretention facility is draining correctly. Look for standing water or soggy, saturated soil. Look for holes containing standing water that encourage mosquitoes. This is a sign of poor drainage from the bioretention facility. Water should drain from bioretention planter within 24-72 hours. After 72 hours, there should be no patches of standing water. Bioretention facility should drain evenly.</i> | <i>Determine the cause of poor drainage (i.e. siltation of engineered soil mix, blocked subdrains, blocked catch basin, blocked storm drain) and repair. Fill holes containing water with proper soil mix. Tilling of soil mix may be required, after several years, the soil medium may become impermeable because of silt deposition, in which case removal and replacement of the soil mix and rock material will be required.</i> |
| <b>Before each dry season and each month throughout the dry season</b> | <i>Test the irrigation system. Observe whether all ground cover areas within the bioretention facilities are receiving the correct amount of water. Observe whether excessive irrigation is creating flow in the subdrains (irrigation should not create any flow in the subdrain)</i>  | <i>Clean out all plugged sprinkler heads and filters. Straighten any displaced sprinkler heads. Replace any damaged sprinkler heads. Adjust for direction and throw distance. Prevent over spray into catch basin. Set the sprinkler timer to provide enough water, depending on the anticipated weather, until the next irrigation inspection. Reduce the watering time if excess water flows from the subdrains.</i>                |



|   |   |   |
|---|---|---|
| (April to October)  |   |   |
| <b>When the bioretention facility is reaching its estimated replace date</b><br>(10-15 years) | <i>Bioretention facilities are failing to drain and normal maintenance activities have failed to rectify problem.</i> | <i>Thorough inspection of bioretention facilities by a licensed professional (i.e., landscape contractor, landscape architect, civil engineer, etc.), replacement of failed components and repair of bioretention facilities to design specifications per the details developed by a registered professional.</i> |
|   | <i>Observe if tree roots are exposed, or if tree is in poor health.</i>   | <i>Replace tree as needed.</i>  |

### Maintenance of Tree-Well Filters (If Applicable)

Designer to include a Table or equivalent that effectively details the frequencies associated to each Tree Well maintenance activity. Include language indicating the Tree-Well Manufacturer. Maintenance instructions should be based on the Manufacturer’s recommendation.

**Sample Language:** *\*Note if extensive measures and related maintenance are incorporated, designer may want to include table as an Appendix.*

#### Tree-Well Maintenance Visit Summary

*Tree well maintenance visits are scheduled seasonally, once after winter rains and once in the fall to prepare for coming storms. The [Project Title] uses [Manufacturer] tree wells. Maintaining a tree well and surrounding area includes:*

- 1. Inspect drainage area and flow-line draining to tree well.*
- 2. Remove tree grate and erosion control stones.*
- 3. Remove debris, trash, and mulch in tree well.*
- 4. Replace mulch with manufacturer’s approved mulch only (Gro-Well Premium Black Colored Mulch).*
- 5. Check tree health, and prune or replace as necessary.*
- 6. Clean area around tree well.*
- 7. Complete log/documentation of maintenance.*

#### Tree-Well Manufacturer’s Cut-Sheets

Designer to include the Manufacturer’s recommended maintenance procedures, inspections, and checklists related to the Tree-Wells installed.

### Maintenance of In-Vault Media Filters (If Applicable)

Designer to include language that effectively details the frequencies and maintenance activity associated with each in-vault media filter. Include language indicating the In-Vault Media Filter Manufacturer. Maintenance instructions should be based on the Manufacturer’s recommendation.



## In-Vault Media Filter Manufacturer's Cut-Sheets

Designer to include the Manufacturer's recommended maintenance procedures, inspections, and checklists related to the In-Vault Media Filters installed.

## ***Maintenance of Trash Control Measures (If Applicable)***

Designer to include language that effectively details the frequencies and maintenance activity associated with each source control measure, if not already described in the Bioretention Facility language. Include language indicating the device Manufacturer, if applicable. Maintenance instructions should be based on the Manufacturer's recommendation.

## Trash Control Device Manufacturer's Cut-Sheets

Designer to include the Manufacturer's recommended maintenance procedures, inspections, and checklists related to the trash control measures installed, if applicable.



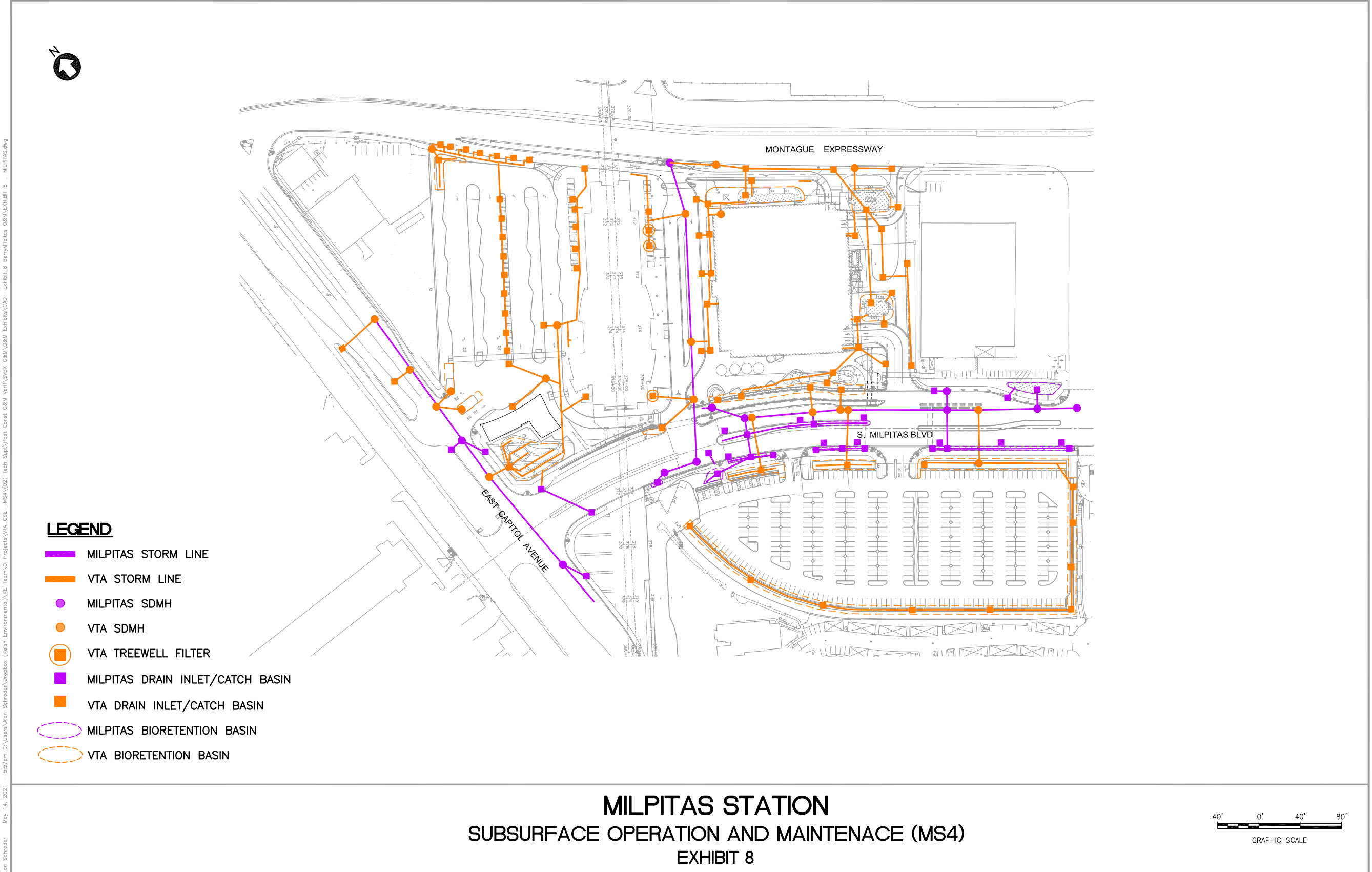

Alan Schroder May 14, 2021 5:57pm C:\Users\Alan\_Schroder\Dropbox (Kishah Environmental)\KE\_Team\0-Projects\VTA\_CSE-MSA\02\_Tech\_Sup\Post\_Const\_0&M\_Verif\SVBX\_0&M\O&M\_Exhibits\CAD-Exhibit\_8\_Berry\Milpitas\_0&M\EXHIBIT\_8 - MILPITAS.dwg







Inlets/Outlets/Pipes

How many inlet structures are present?

- 0 1 2 3 4 5  > 5

Are any of the inlet structures clogged? If yes, mark the location on your site map and fill in the boxes below with the cause of the clogging (i.e., debris, sediment, vegetation, etc.)

- No Partially Completely NA

Are any of the inlet structures altered from the original design or otherwise in need of maintenance? If yes, write in reason (i.e., frost heave, vandalism, unknown, etc.)

| Notes                                    |
|--|
| <br><br><br><br><br><br><br><br><br><br> |

Are any trash screens, overflows, or subdrain/underdrains clogged?

- No  Partially  Completely  NA

- a. If yes, mark the location on your site map and fill in the boxes below with the cause of the clogging (i.e., debris, sediment, vegetation, etc.)
- b. Are any of the overflow or bypass structures altered from the original design or otherwise in need of maintenance? If yes, write in reason (i.e., frost heave, vandalism, unknown)

| Notes                                    |
|--|
| <br><br><br><br><br><br><br><br><br><br> |



Vegetation

What is the approximate vegetation survival rate?\_\_\_\_\_%

a. Does the current vegetation match the original design?

- Yes  No  Unknown

b. Is there the presence of:

Diseased plants

Weeds

Noxious weeds

None of the above

Other: \_\_\_\_\_

c. Does the vegetation appear to be healthy?

- Yes  No (If no, describe below)

d. Is the vegetation the appropriate size and density?

- Yes  No (If no, describe below)

e. Does the current vegetation match the original design?

- Yes  No (If no, describe below)

f. Is there the presence of:

Diseased plants

Weeds

Noxious weeds

None of the above

Other:

g. Does the current vegetation match the original design?

- Yes  No  Unknown

h. Does the vegetation appear to be healthy?

- Yes  No (If no, describe below)





Summary

Inspector's Recommendations. When is maintenance needed?

- Immediately
- Within a month or two
- Within a year
- No sign that any maintenance is required

Summarize the results of this inspection and write any other observations in the box below.

| Notes |
|-------|
|       |



## Appendix C: VTA Approved Pesticides (Sample)

| VTA APPROVED GENERAL USE PESTICIDES                         |             |           |  |                     |                      |   |
|---|-------------|-----------|--|---------------------|----------------------|---|
| Product Name  | Type        | EPA #     | Ingredients  | Precautionary Label | Use Limitation Type* | Suggested Use Limitations**                               |
| Alpine Dust Insecticide                                     | Insecticide | 499-527   | 1 Guanadine, N"-methyl-N-nitro'- [(tetrahydro-3-furanyl)methyl]-, 0.25%; Iron Oxide, 103%; aluminum oxide, 307%; diatomaceous earth, 99% | NA                  | NA                   | NA  |
| Cardinal Food Plant 5-1 Insecticide                         | Insecticide | 8536-35   | Pyrethrins, Piperonyl Butoxide, Petroleum distillates  | Danger              | NA                   | NA  |
| Dimension Ultra 40WP Specialty Herbicide                    | Herbicide   | 62719-445 | dithiopyr: 3,5 pyridinedicarbothioic acid, 2 (difluoromethyl)-4-(2-methylpropyl)- 6-(trifluoromethyl)- S,S-dimethyl ester, 40%           | Caution             | NA                   | NA  |
| Drione  | Insecticide | 432-992   | Pyrethrin, Piperonyl butoxide, amorphous silicon dioxide hydrate, isoparaffinic petroleum solvent  | Caution             | NA                   | NA  |
| Gentrol Point Source Roach Control Device                   | Insecticide | 2724-469  | Hydroprene 96%   | Warning             | Contractor Use Only  | NA  |
| Maxforce FC Professional Insect Control Ant Killer Bait Gel | Insecticide | 432-1264  | Fipronil 0.001%  | Caution             | More Limited         | Not for use in outdoor areas with potential rain exposure |

\*Use limitation type is determined by VTA

\*\* Suggested use limitations is determined by considering a product's hazard tier rating, formulation, likely exposure, and typical uses. Excerpt from 2017 San Francisco Reduced-Risk Pesticide List



| VTA APPROVED GENERAL USE PESTICIDES                                       |                |           |   |                     |                           |  |
|---|----------------|-----------|---|---------------------|---------------------------|--|
| Product Name  | Type           | EPA #     | Ingredients   | Precautionary Label | Use Limitation Type*      | Suggested Use Limitations**  |
| Maxforce FC Professional Insect Control Roach Killer Bait Gel             | Insecticide    | 432-1259  | Fipronil 0.01%  | Caution             | Contractor use only.      | Not for use in outdoor areas with potential rain exposure  |
| Milestone   | Herbicide      | 62719-519 | Aminopyralid, tri-isopropanolamine salt (5928) 40.6%  | Caution             | More Limited              | For invasive species in natural areas or parklands where other alternatives are ineffective, especially for invasive legumes and composites such as yellow star thistle and purple star thistle. |
| NIBAN-FG  | Pesticide Bait | 64405-2   | Orthoboric Acid, 5%   | Caution             | NA                        | NA   |
| Phantom Termiticide   | Insecticide    | 241-392   | Chlorfenapyr, 21.45%; Propylene glycol, 7.5%  | Danger              | Contractor Use Only       | NA   |
| Prescription Treatment Brand Wasp-Freeze Wasp and Hornet Killer Formula 1 | Insecticide    | 499-362   | Phenothrin 12%, d-trans allethrin .129%, CO2  | Danger              | Most Limited              | Use only when a concern for public safety, and in situations where use of EcoExempt product is inadequate or unsafe.   |
| PT 565 Plus XLO Pressurized Contact Insecticide                           | Insecticide    | 499-290   | Pyrethrins, 0.5%; Acetone, 50-75%; Petroleum, 1-3%; Piperonylbutoxide, 1-3%; n-Octyl bicycloheptene dicarboximide, 1-3% | Danger              | Contractor Use Only       | NA   |
| PT Ultracide Pressurized Flea Insecticide                                 | Insecticide    | 499-404   | Pyriproxyfen, 0.10%; pyrethrins, 0.05%; n-octyl bicycloheptene dicarboximide, 0.40%; permethrin, 0.40%                  | Caution             | Vendor Use Only- Terminix | NA   |
| Roundup Pro Herbicide   | Herbicide      | 524-529   | isopropylamine salt of N-(phosphonomethyl) glycine  | Caution             | NA                        | NA   |

\*Use limitation type is determined by VTA

\*\* Suggested use limitations is determined by considering a product's hazard tier rating, formulation, likely exposure, and typical uses. Excerpt from 2017 San Francisco Reduced-Risk Pesticide List



| VTA APPROVED GENERAL USE PESTICIDES    |             |          |  |                     |                      |  |
|--|-------------|----------|--|---------------------|----------------------|--|
| Product Name                           | Type        | EPA #    | Ingredients  | Precautionary Label | Use Limitation Type* | Suggested Use Limitations**  |
| <b>Roundup Promax Herbicide</b>        | Herbicide   | 524-579  | Glyphosate, isopropylamine salt 48.7%  | Caution             | Most Limited         | Use of Aquamaster + Competitor is preferred except in situations where rainfastness is needed. |
| <b>Talstar EZ Gracular Insecticide</b> | Insecticide | 279-3168 | Bifenthrin, 0.2%   | Caution             | NA                   | NA   |
| <b>Wasp Freeze</b>                     | Herbicide   | NA       | d-trans Allethrin, d-Phenothrin, Distillates (petroleum), hydrotreated light, Carbon dioxide | Danger              | NA                   | NA   |





**ATTACHMENT L:**  
L2: SAMPLE O&M PLAN



## SVBX Post-Construction BMP Operations and Maintenance Guidelines



*A guide for the care and maintenance of the SVBX bioretention basins*



**Table of Contents**

SVBX POST-CONSTRUCTION BMP OPERATIONS AND MAINTENANCE GUIDELINES ..... 1

Background..... 3

Stormwater Facility Operation and Maintenance Agreements ..... 3

Records..... 3

Safety ..... 3

Tools..... 4

Maintenance of Bioretention Facilities ..... 4

Bioretention Facility Maintenance Table ..... 5

Tree Well Maintenance Guidelines ..... 8

Maintenance Visit Summary..... 8

Maintenance Tools, Safety Equipment and Supplies..... 8

Filtterra® Maintenance Visit Procedure ..... 9

Filtterra® Tree Box Maintenance Checklist..... 11

Appendix A: Bioretention Basins and Tree Well Index ..... 12

Appendix B: Facilities Map..... 14

Appendix C: Bioretention Inspection Form ..... 25

Appendix D: VTA Approved Pesticides ..... 29





## Background

The Santa Clara Valley Transportation Authority (VTA) Silicon Valley Berryessa Extension (SVBX) project consists of ten miles of track and two Bay Area Rapid Transit (BART) BART/VTA stations. Post-construction stormwater treatment facilities, including bioretention basins and tree well filters, were installed as part of the drainage features along some of the BART track and at both stations. Bioretention basins and tree well filters are permanent best management practices (BMPs) used to filter out pollutants from stormwater runoff discharging from the project. The runoff from the project travels via the storm drain system into local creeks that discharge to South San Francisco Bay.

Bioretention facilities are composed of a bottom layer of drainage rock with an underdrain/subdrain, and depending on the soil conditions, there may be an impermeable liner. A second layer of engineered soil (media) is placed over the rock with site specific plants. This is then topped with mulch. In some cases where irrigation was not available, plants were not installed and instead a bioretention grass seed was spread via hydroseed.

Tree wells consist of a subsurface concrete structure that contains a proprietary media to filter stormwater runoff along with a single tree. The proprietary media is used to obtain high flow rates through the tree well, and still filter out pollutants.

Both types of stormwater BMPs have a site-specific drainage management area (DMA), or area of runoff that they treat. The list of stormwater BMPs can be found in Appendix A.

## Stormwater Facility Operation and Maintenance Agreements

VTA will enter into Operation and Maintenance (O&M) Agreements with the City of San Jose and the City of Milpitas to each maintain the BMPs that treat runoff from their respective right-of-way. Maps showing the locations of VTA and City BMPs including the two station areas can be found in Appendix B.

## Records

The VTA O&M inspections and necessary maintenance will be performed by in-house VTA staff or contractors at VTA's discretion. Inspection and Maintenance checklists will be completed per in-house standard or contract requirements for each BMP. These will be submitted to the following address:

VTA Environmental Programs

Attn: Roy Molseed – VTA MS4 Stormwater Program Project Manager

3331 North First Street

San Jose, CA 95134

Oversight inspections will be performed by VTA Environmental Programs as part of the Municipal Stormwater (MS4) permit requirements. A sample inspection form is shown in Appendix C: Stormwater Facilities Inspection Form.

## Safety

Use of maintenance equipment shall be according to the manufacturer's procedures and instructions and according to VTA and Cal OSHA requirements.

### General Safety Guidelines

- Set up a safety perimeter and be aware of passing pedestrians, bicycles, and vehicles.
- Do not stand in the street when performing maintenance activities unless traffic control has safely blocked a lane.
- Make yourself visible. Wear bright colored clothing and a safety vest.





- Wear hard hats (as required), protective clothing, thick gloves, and sturdy shoes.
- Be aware when cutting plants and branches overhead or when working on an active construction site.
- Wear eye and ear protection.
- Be aware of broken glass, sharp objects, and other hazards.
- Be aware of needles and other biohazards. Use grabbers and gloves to remove needles and dispose of them properly.
- Be aware of loose material, standing water, tripping hazards, uneven ground, and other obstructions.
- Don't leave your tools unattended. Keep them out of the street and off the sidewalk so they don't pose a hazard to others.
- Perform maintenance on your facility during daylight hours and avoid peak traffic times.

## Tools

Ideal tools include: camera, edging Spade, trash bags, work gloves, plant and weed photo ID sheet, tarp/buckets/trash cans (to remove leaf litter/debris), high-visibility clothes/vest, push broom, wheelbarrow, hand trowel, rake, hoe, manhole cover hook or lifter (for opening grates), flat shovel, wrenches and other tools required to unbolt manhole cover and grate locks, hedge shears and loppers, hand weeding tools, and hori-hori.

## Maintenance of Bioretention Facilities

Bioretention facilities remove pollutants by filtering runoff slowly through an active layer of soil media. Dissipation rock placed at the inlets helps to prevent erosion of the mulch at the bioretention facilities. In addition, the media is held together by plant roots which help to biologically remediate some of the pollutants. To ensure continued effectiveness, regular maintenance is needed and consists of the following:

- a. Inspect the dissipation rock area at the inlets for channels, exposed soils, or other evidence of erosion. Clear any obstructions such as trash or debris and remove any accumulation of foreign sediment. Examine dissipation rock and replenish if necessary.
  - i. If the inlet is not a standard street drain inlet or a concrete structure, then inspect the transition area (from the paved treated area to the basin) for erosion.
  - ii. Inspect side slopes for evidence of instability or erosion and correct as necessary.
- b. Observe soil at the bottom of the bio-retention facilities for uniform percolation throughout. If portions of the planter do not drain within 24-72 hours after a storm event, the soil should be tilled and replanted.
- c. Confirm that check dams and flow spreaders are in place and level and that channelization within the bioretention facility is effectively prevented.
- d. Examine the vegetation to ensure that it is healthy and dense enough to provide filtering and to protect soils from erosion.
- e. Replenish mulch as necessary, remove accumulated leaves, trash and debris, prune shrubs or trees, and mow turf areas. When mowing, remove no more than 1/3 of the grass height. Confirm that



irrigation is adequate and not excessive. Replace dead plants and remove noxious and invasive weeds.

- f. Abate any potential vectors by filling holes in the ground in and around the bioretention facility and by insuring that there are no areas where water stands longer than 24-72 hours following a storm. If mosquito larvae are present and persistent, contact the Santa Clara County Vector Control for information and advice. Any mosquito larvicides should be applied only when absolutely necessary and only by a licensed individual or contractor.

Bioretention Facility Maintenance Table

| Frequency | Observation   | Maintenance Activity  |
|-----------|---|---|
| Yearly    | <ul style="list-style-type: none"> <li>• Inspect the bioretention facility mulch and media elevations.</li> </ul>   | <ul style="list-style-type: none"> <li>• If mulch has floated to one side or media elevation is too low, adjust the elevations and re-spread the media.</li> </ul>  |
|           | <ul style="list-style-type: none"> <li>• Inspect the elevation of the dissipation rock.</li> </ul>  | <ul style="list-style-type: none"> <li>• If the dissipation rock is spread out or sunk into the media, rearrange in front of the inlet or transition area between the paved area and the facility.</li> </ul>   |
|           | <ul style="list-style-type: none"> <li>• Inspect the growth of trees and look for trunk pitch.</li> </ul>   | <ul style="list-style-type: none"> <li>• If tree is leaning, check the support pole connections, remove any large branches to offset weight, or replant if the pitch is too great to correct.</li> </ul>  |
| Monthly   | <ul style="list-style-type: none"> <li>• Inspect the bioretention facility for litter, debris, leaves, dead vegetation and anything else that might interfere with flow, filtration or growth of the plants.</li> </ul> | <ul style="list-style-type: none"> <li>• Remove all litter, debris, leaves, dead vegetation, etc.</li> <li>• Replace dead vegetation as appropriate.</li> </ul>   |
|           | <ul style="list-style-type: none"> <li>• Inspect for growth of invasive plants.</li> </ul>  | <ul style="list-style-type: none"> <li>• Remove any invasive plants, weeds or shrubs by hand in the basin.</li> <li>• Do not apply herbicides or pesticide within the basin area, as they are a direct MS4 connection.</li> <li>• Spray minimum amount necessary to control pests near the basin. If pesticides must be used, then pesticide application is to be performed by a licensed professional pest control contractor trained in Integrated Pest Management (IPM)</li> </ul> |





|  |   |   |
|--|---|---|
|  |   | techniques (see list of VTA approved pesticides in Appendix D).   |
|  | <ul style="list-style-type: none"> <li>Inspect the condition of plantings. Plantings must be maintained in a healthy condition without use of conventional fertilizers or pesticides. Grass must be of sufficient density and health to provide filtration and to protect from erosion.</li> <li>Inspect the condition of other vegetation found in the bioretention facility. Vegetation must be of sufficient density and health to provide filtration and protect from erosion.</li> </ul> | <ul style="list-style-type: none"> <li>Reseed bare spots and mow as necessary.</li> </ul>   |
| Before each rainy season (early October or prior to significant storm) | <ul style="list-style-type: none"> <li>Look for any obstructions that will prevent water from flowing into the bioretention facility such as: trash/debris and vegetation.</li> </ul>   | <ul style="list-style-type: none"> <li>Remove obstructions, clean up litter and maintain vegetation.</li> </ul>   |
|  | <ul style="list-style-type: none"> <li>Inspect bioretention facilities. Look for gullies, washouts, evidence of uncontrolled surface water flow or any other evidence of erosion in the bioretention facilities.</li> </ul>   | <ul style="list-style-type: none"> <li>Replacement soil to be placed by hand tools only and avoid compaction. Any basin compaction should be due to watering only.</li> </ul>                           |
|  | <ul style="list-style-type: none"> <li>Determine whether the bioretention facility is draining correctly (i.e. drains in less than 24-72 hours after a storm event). Inspect adjacent infrastructure, such as retaining walls, curbs and pavement for signs of failure caused by water intrusion into the surrounding soil. This is a sign of poor drainage from the bioretention facility.</li> </ul>  | <ul style="list-style-type: none"> <li>Determine the cause of poor drainage (i.e. siltation of engineered soil mix, blocked subdrains, blocked catch basin, blocked storm drain) and repair.</li> </ul> |
|  | <ul style="list-style-type: none"> <li>Inspect each subdrain where it enters the catch basin to see whether the subdrain pipe is dry or is clogged. Ensure that the subdrain is flowing by testing with water from the cleanout end.</li> </ul>   | <ul style="list-style-type: none"> <li>If water does not flow through the subdrain, rod or flush the line to ensure flow.</li> </ul>  |





|  |  |  |
|--|--|--|
|  | <ul style="list-style-type: none"> <li>Inspect all subdrain cleanouts. Ensure that all cleanout caps are present. Look for obstructions, debris, trash, leaves, vegetation, etc., growing inside the subdrain or covering the cleanout.</li> </ul>   | <ul style="list-style-type: none"> <li>Remove any obstructions by hand (if near the cleanout entrance) or by flushing (with pressurized water) if too far down the pipe. Replace missing caps and secure to prevent unauthorized removal or accidental displacement.</li> </ul>  |
|  | <ul style="list-style-type: none"> <li>Inspect the entire storm drain system from the upstream end to the outfall, including all catch basins. Observe the flow of water. Any evidence of ponding in the catch basins may indicate a blockage or high groundwater.</li> </ul>  | <ul style="list-style-type: none"> <li>Find and remove any obstructions. Flushing (with pressurized water) may be necessary.</li> </ul>  |
|  | <ul style="list-style-type: none"> <li>Inspect all catch basins. Look for obstructions, vegetation, debris, litter, sediment, etc. blocking the catch basins.</li> </ul>   | <ul style="list-style-type: none"> <li>Remove obstructions and clean drain inlets and catch basins.</li> </ul>   |
| After the first heavy rain (a rain event more than 0.5")                           | <ul style="list-style-type: none"> <li>Determine whether the bioretention facility is draining correctly. Look for standing water or soggy, saturated soil. Look for holes containing standing water that encourage mosquitoes. This is a sign of poor drainage from the bioretention facility. Water should drain from bioretention planter within 24-72 hours. After 72 hours, there should be no patches of standing water. Bioretention facility should drain evenly.</li> </ul> | <ul style="list-style-type: none"> <li>Determine the cause of poor drainage (i.e. siltation of engineered soil mix, blocked subdrains, blocked catch basin, blocked storm drain) and repair. Fill holes containing water with proper soil mix. Tilling of soil mix may be required, after several years, the soil medium may become impermeable because of silt deposition, in which case removal and replacement of the soil mix and rock material will be required.</li> </ul> |
| Before each dry season and each month throughout the dry season (April to October) | <ul style="list-style-type: none"> <li>Test the irrigation system. Observe whether all ground cover areas within the bioretention facilities are receiving the correct amount of water. Observe whether excessive irrigation is creating flow in the subdrains (irrigation should not create any flow in the subdrain)</li> </ul>  | <ul style="list-style-type: none"> <li>Clean out all plugged sprinkler heads and filters. Straighten any displaced sprinkler heads. Replace any damaged sprinkler heads. Adjust for direction and throw distance. Prevent over spray into catch basin. Set the sprinkler timer to provide enough water, depending on the anticipated weather, until the next irrigation inspection. Reduce the watering time if excess water flows from the subdrains.</li> </ul>                |







|  |  |   |
|--|--|---|
| <p>When the bioretention facility is reaching its estimated replace date (10-15 years)</p> | <ul style="list-style-type: none"> <li>• Bioretention facilities are failing to drain and normal maintenance activities have failed to rectify problem.</li> </ul> | <ul style="list-style-type: none"> <li>• Thorough inspection of bioretention facilities by a licensed professional (i.e. landscape contractor, landscape architect, civil engineer, etc.), replacement of failed components and repair of bioretention facilities to design specifications per the details developed by a registered professional.</li> </ul> |
|  | <ul style="list-style-type: none"> <li>• Observe if tree roots are exposed, or if tree is in poor health.</li> </ul>   | <ul style="list-style-type: none"> <li>• Replace tree as needed.</li> </ul>   |

**Tree Well Maintenance Guidelines**

Tree well maintenance visits are scheduled seasonally, once after winter rains and once in the fall to prepare for coming storms.

**Maintenance Visit Summary**

The SVBX project uses Filterra® tree wells. Maintaining a tree well and surrounding area includes:

1. Inspect drainage area and flow-line draining to tree well.
2. Remove tree grate and erosion control stones.
3. Remove debris, trash, and mulch in tree well.
4. Replace mulch with manufacturer’s approved mulch only (Gro-Well Premium Black Colored Mulch).
5. Check tree health, and prune or replace as necessary.
6. Clean area around tree well.
7. Complete log/documentation of maintenance.

**Maintenance Tools, Safety Equipment and Supplies**

Ideal tools include: camera, bucket, shovel, broom, pruners, hoe/rake, and tape measure. Appropriate Personal Protective Equipment (PPE) should be used in accordance with local or company procedures. This may include impervious gloves where the type of trash is unknown, high visibility clothing, safety hats and shoes, and barricades when working near traffic. A T-Bar or crowbar should be used for moving the tree grates (up to 170 lbs. ea.). Most visits require minor trash removal and a replenishment/replacement of mulch may be necessary.





## Filterra® Maintenance Visit Procedure

Keep sufficient documentation of maintenance actions to predict location specific maintenance frequencies and needs. An example Maintenance Report is included in this manual.



### 1. Inspection of Filterra® and surrounding area

- Record individual unit before maintenance with photograph (numbered). Record on Maintenance Report (see example in this document) the following:

Record on Maintenance Report the following:

|                         |          |
|-------------------------|----------|
| Standing Water          | yes   no |
| Damage to Box Structure | yes   no |
| Damage to Grate         | yes   no |
| Is Bypass Clear         | yes   no |

If yes answered to any of these observations, record with close-up photograph (numbered).



### 2. Removal of tree grate and erosion control stones

- Remove cast iron grates for access into Filterra® box.
- Dig out silt (if any) and mulch and remove trash & foreign items.

Record on Maintenance Report the following:

|                      |          |
|----------------------|----------|
| Silt/Clay            | yes   no |
| Cups/ Bags           | yes   no |
| Leaves               | yes   no |
| # of Buckets Removed | _____    |



### 3. Removal of debris, trash and mulch

- After removal of mulch and debris, measure distance from the top of the Filterra® engineered media soil to the bottom of the top slab. If this distance is greater than 12", add Filterra® media (not top soil or other) to recharge to a 9" distance

Record on Maintenance Report the following:

|   |       |
|---|-------|
| Distance of Bottom of Top Slab (inches) | _____ |
| # of Buckets of Media Added             | _____ |



**4. Mulch replacement**

- Please see mulch specifications.
- Add double shredded mulch evenly across the entire unit to a depth of 3".
- Ensure correct repositioning of erosion control stones by the Filterra® inlet to allow for entry of trash during a storm event.
- Replace Filterra® grates correctly using appropriate lifting or moving tools, taking care not to damage the plant.



**5. Plant health evaluation and pruning or replacement as necessary**

- Examine the plant's health and replace if dead.
- Prune as necessary to encourage growth in the correct directions

Record on Maintenance Report the following:

|                       |       |              |
|-----------------------|-------|--------------|
| Height above Grate    | _____ | (ft)         |
| Width at Widest Point | _____ | (ft)         |
| Health                |       | alive   dead |
| Damage to Plant       |       | yes   no     |
| Plant Replaced        |       | yes   no     |



**6. Clean area around Filterra®**

- Clean area around unit and remove all refuse to be disposed of appropriately.



**7. Complete paperwork**

- Deliver Maintenance Report and photographs to appropriate location (normally Contech during maintenance contract period).
- Some jurisdictions may require submission of maintenance reports in accordance with approvals. It is the responsibility of the Owner to comply with local regulations.





Filterra® Tree Box Maintenance Checklist

| Drainage System Failure | Problem                                   | Conditions to Check   | Condition that Should Exist   | Actions   |
|-------------------------|---|---|---|---|
| Inlet                   | Excessive sediment or trash accumulation. | Accumulated sediments or trash impair free flow of water into Filterra.   | Inlet should be free of obstructions allowing free distributed flow of water into Filterra. | Sediments and/or trash should be removed.   |
| Mulch Cover             | Trash and floatable debris accumulation.  | Excessive trash and/or debris accumulation.   | Minimal trash or other debris on mulch cover.   | Trash and debris should be removed and mulch cover raked level. Ensure bark nugget mulch is not used. |
| Mulch Cover             | "Ponding" of water on mulch cover.        | "Ponding" in unit could be indicative of clogging due to excessive fine sediment accumulation or spill of petroleum oils. | Stormwater should drain freely and evenly through mulch cover.                              | Recommend contact manufacturer and replace mulch as a minimum.  |
| Vegetation              | Plants not growing or in poor condition.  | Soil/mulch too wet, evidence of spill. Incorrect plant selection. Pest infestation. Vandalism to plants.                  | Plants should be healthy and pest free.   | Contact manufacturer for advice.  |
| Vegetation              | Plant growth excessive.                   | Plants should be appropriate to the species and location of Filterra.   |   | Trim/prune plants in accordance with typical landscaping and safety needs.                            |
| Structure               | Structure has visible cracks.             | Cracks wider than 1/2 inch or evidence of soil particles entering the structure through the cracks.                       |   | Vault should be repaired.   |

*Maintenance is ideally to be performed twice annually.*





Appendix A: Bioretention Basins and Tree Well Index

| <b>VTA Post-Construction Stormwater Treatment Areas – Construction Nomenclature</b>            |                          |                  |              |
|--|--------------------------|------------------|--------------|
| <b>SVBX Silicon Valley Berryessa Extension (Basins from North to South down the alignment)</b> |                          |                  |              |
| <b>SVBX Alignment Location</b>   | <b>Type of treatment</b> | <b>VTA BMP#:</b> | <b>Map#:</b> |
| South of 237, Industrial Rd (STA 289+70 to 296+68, on exhibit )                                | Bioretention Basin       | ID- BR-01        | Exhibit 5c   |
| Piper Drive (STA 359+70 to 364+00)   | Bioretention Basin       | PR-BR-02         | Exhibit 5d   |
| <b>Milpitas Station/Parking Garage</b>   |                          |                  |              |
| Series of basins along the Montague Bus entrance   | Bioretention Basin       | MS-BR-03         | Exhibit 4    |
| North West Basin in the Bus Circle   | Bioretention Basin       | MS-BR-04         | Exhibit 4    |
| North side of the parking structure  | Bioretention Basin       | MS-BR-05         | Exhibit 4    |
| Northeast side of the parking structure  | Bioretention Basin       | MS-BR-06         | Exhibit 4    |
| East side of the parking structure   | Bioretention Basin       | MS-BR-07         | Exhibit 4    |
| Long basin along South Milpitas Blvd VTA bus entrance  | Bioretention Basin       | MS-BR-08         | Exhibit 4    |
| South of Milpitas Station along VTA bus entrance   | Bioretention Basin       | MS-BR-09         | Exhibit 4    |
| Large basin south of the bike locker (Fenced off)  | Bioretention Basin       | MS-BR-10         | Exhibit 4    |
| Between the VTA bus circle entrance and exit   | Bioretention Basin       | MS-BR-11         | Exhibit 4    |
| North of the VTA bus circle exit   | Bioretention Basin       | MS-BR-12         | Exhibit 4    |
| First basin along handicap parking in southern lot   | Bioretention Basin       | MS-BR-13         | Exhibit 4    |
| Second basin back of sidewalk in southern lot  | Bioretention Basin       | MS-BR-14         | Exhibit 4    |
| Third basin back of sidewalk in southern lot   | Bioretention Basin       | MS-BR-15         | Exhibit 4    |
| Fourth basin back of sidewalk in southern lot (Three sections)                                 | Bioretention Basin       | MS-BR-16         | Exhibit 4    |
| Basin that goes the southern and eastern sides of the southern lot                             | Bioretention Basin       | MS-BR-17         | Exhibit 4    |
| Milpitas Station Kiss and Ride (North)   | Filtterra® Tree Well Box | MS-TW-01         | Exhibit 4    |
| Milpitas Station Kiss and Ride (Middle)  | Filtterra® Tree Well Box | MS-TW-02         | Exhibit 4    |
| Milpitas Station Kiss and Ride (South)   | Filtterra® Tree Well Box | MS-TW-03         | Exhibit 4    |
| <b>SVBX Alignment Location</b>   |                          |                  |              |
| North Sierra Lundy (STA 486-60 to 488+40)  | Bioretention Basin       | SL-BR-18         | Exhibit 5g   |
| Berryessa MOW at MSE (STA 509+29 to 514+24 –STA 518+05 to 519+71)                              | Bioretention Basin       | MW-BR-19         | Exhibit 5g   |
| <b>Berryessa Station/Parking Garage</b>  |                          |                  |              |
| East Lot (Northern Basin)  | Bioretention Basin       | BE-BR-20         | Exhibit 3    |
| East Lot (Middle Basin)  | Bioretention Basin       | BE-BR-21         | Exhibit 3    |
| East Lot (Southern Basin)  | Bioretention Basin       | BE-BR-22         | Exhibit 3    |





|  |                    |          |           |
|--|--------------------|----------|-----------|
| Mabury Bus Entrance Road (Second basin in from Mabury)                           | Bioretention Basin | BE-BR-23 | Exhibit 3 |
| East Basin along the parking structure   | Bioretention Basin | BE-BR-24 | Exhibit 3 |
| Basin north of generator house   | Bioretention Basin | BE-BR-25 | Exhibit 3 |
| Southern basin in front of station   | Bioretention Basin | BE-BR-26 | Exhibit 3 |
| Northern basin in front of station   | Bioretention Basin | BE-BR-27 | Exhibit 3 |
| Large basin along VTA bus circle   | Bioretention Basin | BE-BR-28 | Exhibit 3 |
| Basin southwest of the bridge entrance   | Bioretention Basin | BE-BR-29 | Exhibit 3 |
| Basin inside of the BART Police Zone Facility                                    | Bioretention Basin | BE-BR-30 | Exhibit 3 |
| Adjacent to Upper Penitencia Creek, under the BART Tracks (STA 523+80 to 525+00) | Bioretention Basin | BE-BR-31 | Exhibit 3 |
| Adjacent to Mabury, under the BART Tracks (STA 547+27.35-548+32.33)              | Bioretention Basin | BE-BR-32 | Exhibit 3 |





Appendix B: Facilities Map



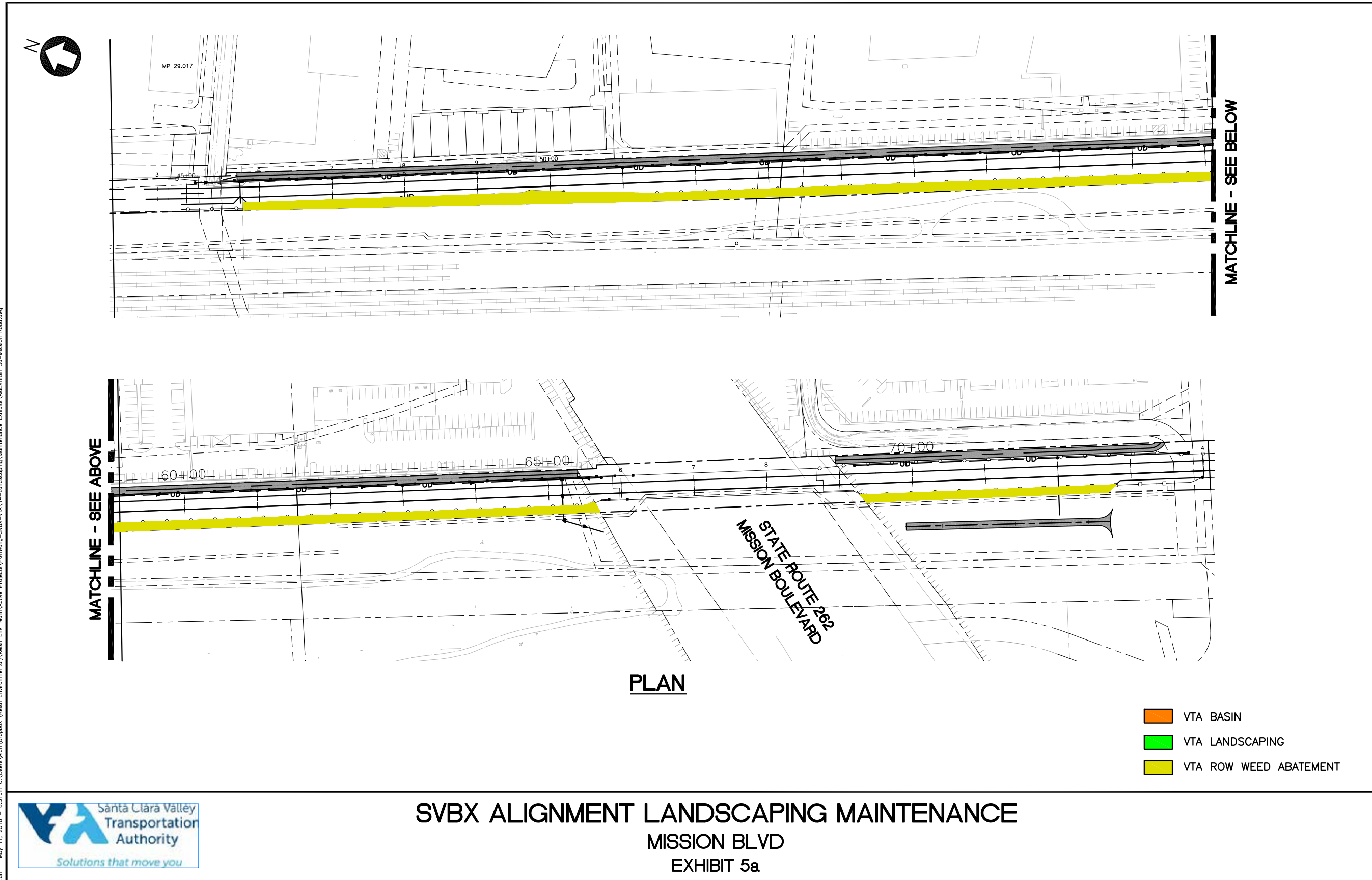

Alon May 11, 2018 - 8:31pm C:\Users\Alon\Dropbox (Kesh Environment)\Kesh Env Team\Active Projects\Chikong-SVBX-VTA\14-Landscaping\Maintenance Exhibit\AKEXHIBIT 5a-Mission Road.dwg



**SVBX ALIGNMENT LANDSCAPING MAINTENANCE**  
**MISSION BLVD**  
**EXHIBIT 5a**



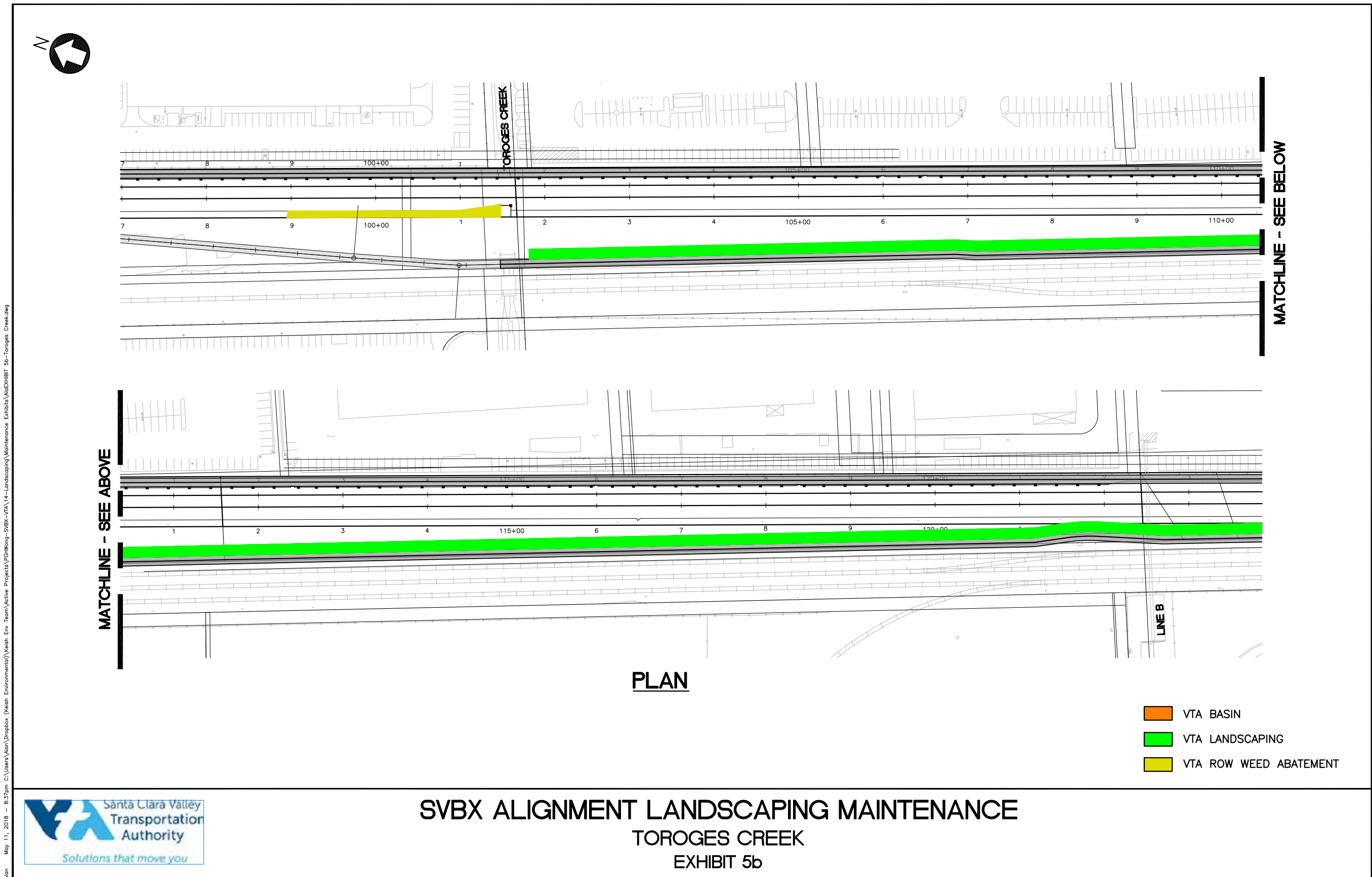





Alon May 11, 2018 - 8:37pm C:\Users\Alon\Dropbox (Keish Environmental)\Keish Env Team\Active Projects\SVBX-VTA-14-Landscaping\Maintenance Exhibit\VA\EXHIBIT 5b-Toroges Creek.dwg

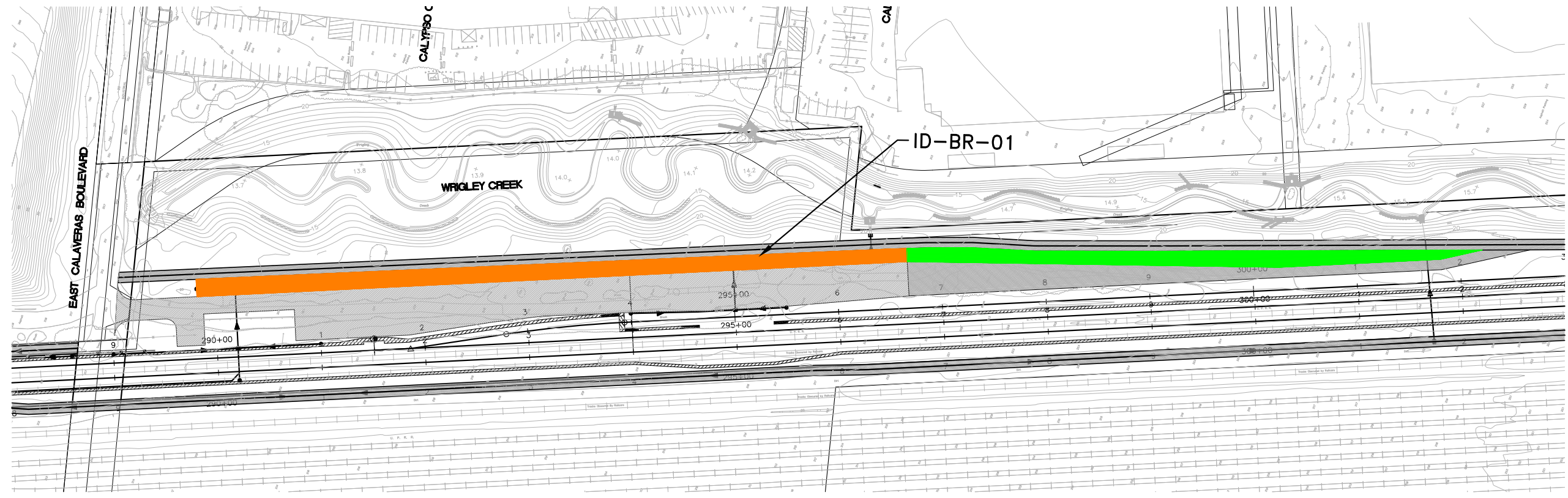
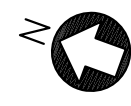

**SVBX ALIGNMENT LANDSCAPING MAINTENANCE**  
**TOROGES CREEK**  
**EXHIBIT 5b**

Alon May 29, 2018 - 8:52pm C:\Users\Aton\Dropbox (Keith Environment)\Projects\FCR\Wong-SVBX-VTA\4-Landscaping\Maintenance Exhibit 5c\EXHIBIT 5c-Calaveras.dwg



-  VTA BASIN
-  VTA LANDSCAPING
-  VTA ROW WEED ABATEMENT

**PLAN**

**SVBX ALIGNMENT LANDSCAPING MAINTENANCE**

**CALAVERAS BLVD**

**EXHIBIT 5c**



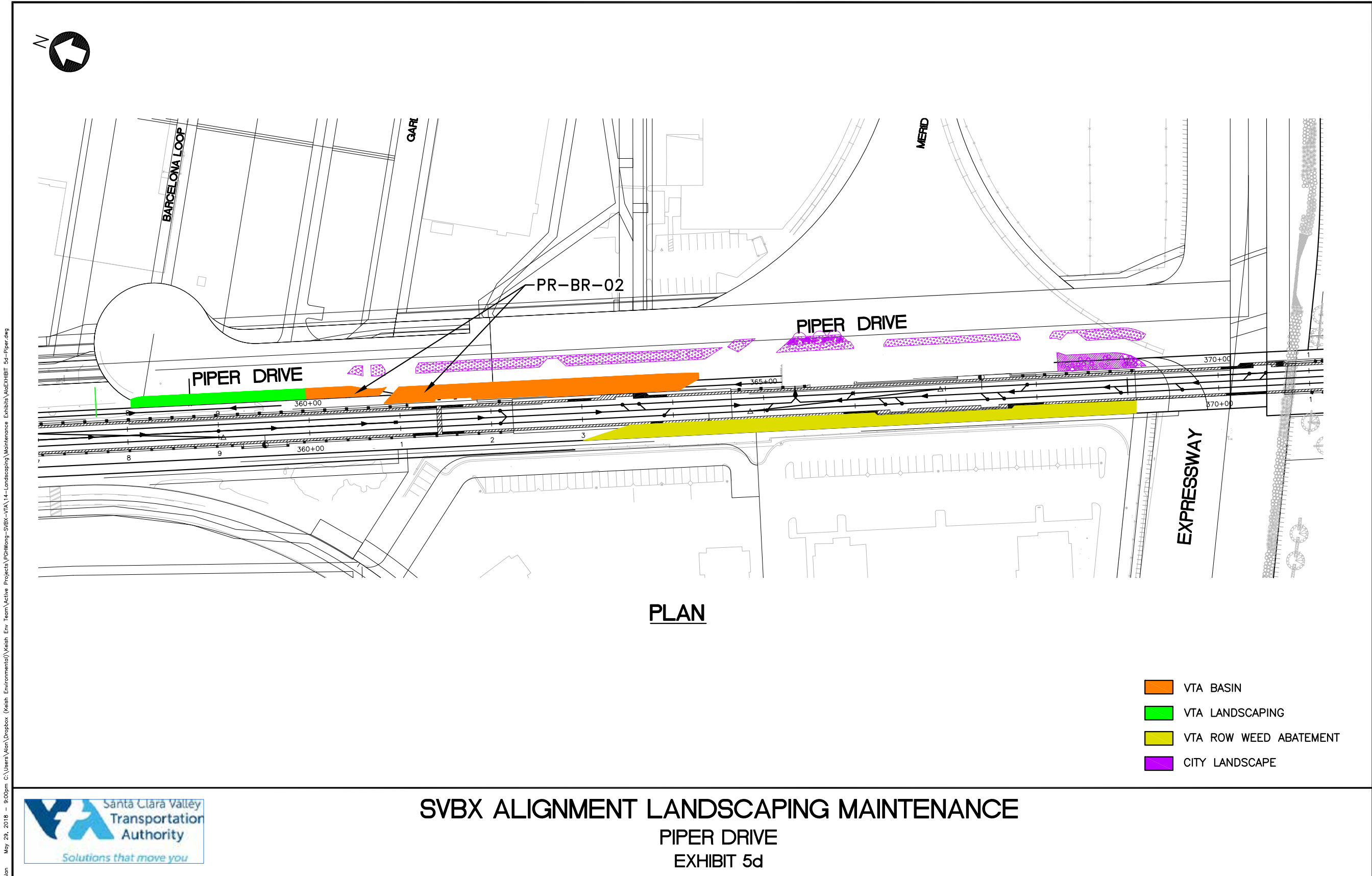

Alan May 29, 2018 - 9:00pm C:\Users\Alan\Dropbox (Keith Environmental)\Keith Env Team\Active Projects\POHWong-SVBX-VTA-14-Landscaping\Maintenance Exhibits\VA\EXHIBIT 5d-Piper.dwg



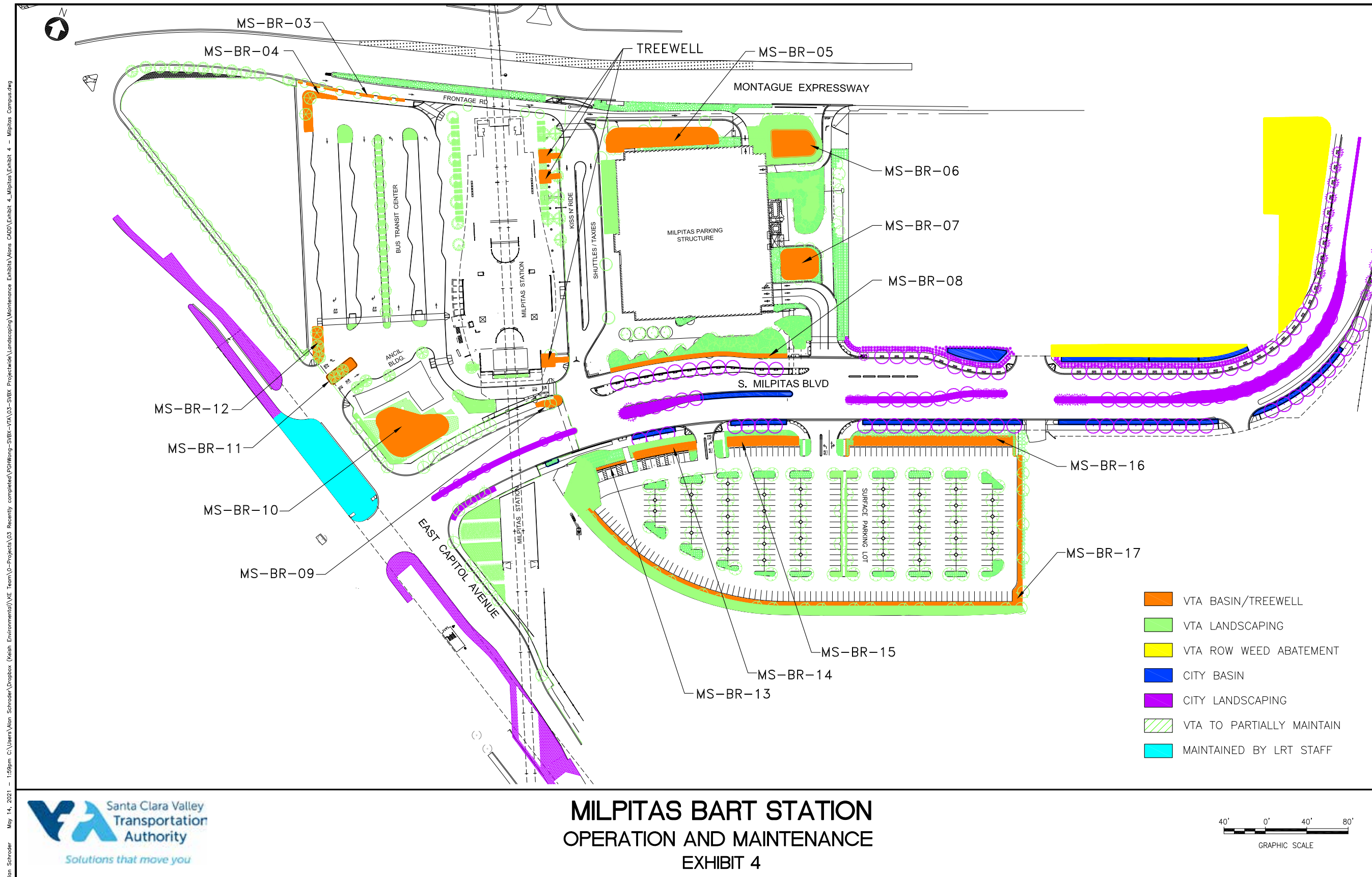

May 14, 2021 - 1:59pm C:\Users\Alan\_Schroder\Dropbox (Kish Environmental)\VE Team\O-Projects\03 Recently completed\PHWong-SYBK-VTA\03-SYBK Projectwide\_Landscaping\Maintenance Exhibit\Plans CADD\Exhibit 4\_Milpitas\Exhibit 4 - Milpitas Campus.dwg  
 Alan Schroder

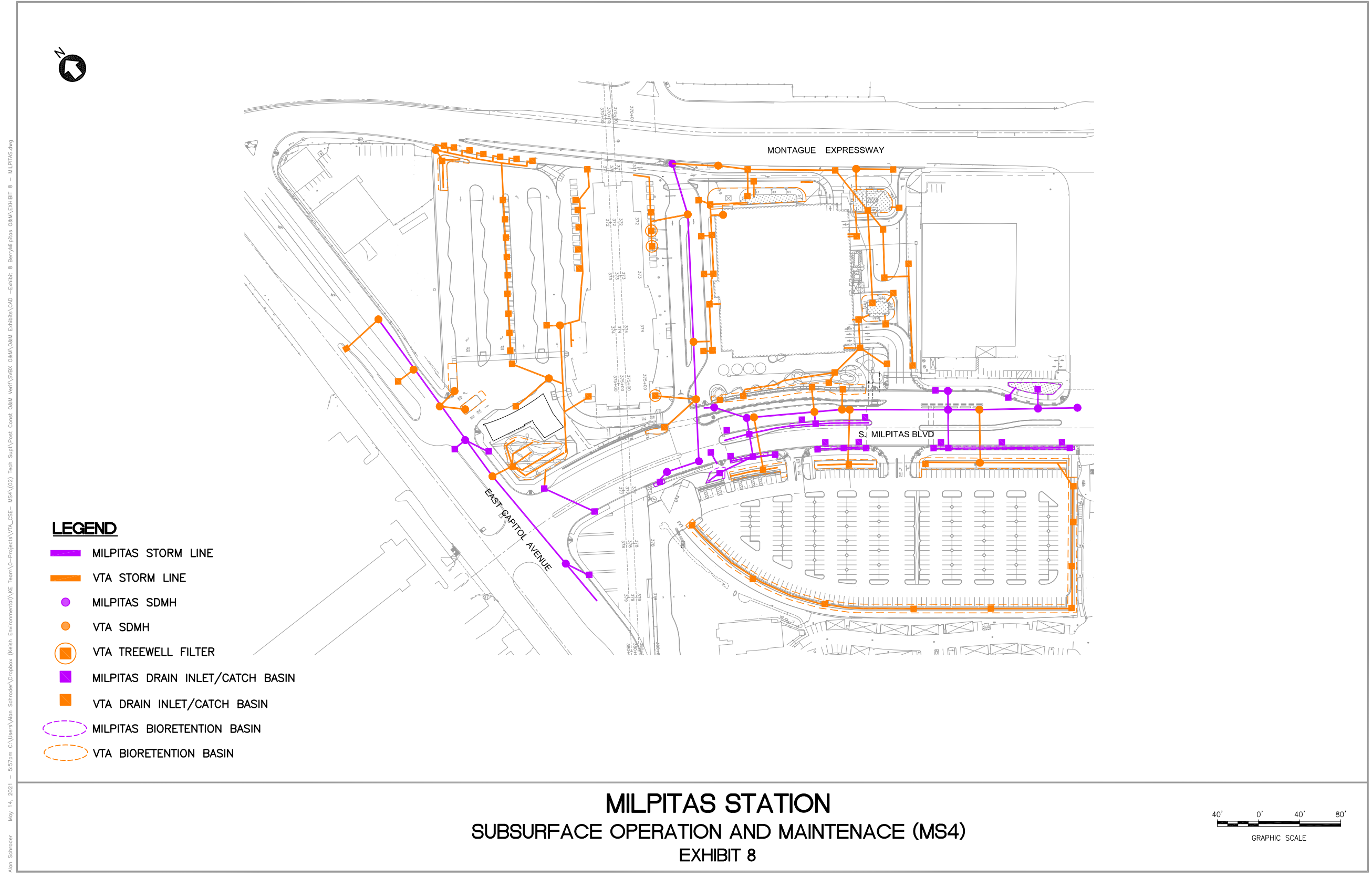

Alan Schroeder May 14, 2021 5:57pm C:\Users\Alan\_Schroeder\Dropbox (Kellan Environmental)\VE Team\0-Projects\VTAL\_CSE- MSA\02 Tech\_Sup\Post\_Const\_O&M\_Vent\018\O&M\_Exhibits\CAD -Exhibit 8 BerryMilpitas O&M\EXHIBIT 8 - MILPITAS.dwg





**Inlets/Outlets/Pipes**

How many inlet structures are present?  0  1  2  3  4  5  > 5

Are any of the inlet structures clogged? (If yes, mark the location on your site map and fill in the boxes below with the cause of the clogging (e.g., debris, sediment, vegetation, etc.)

No  Partially  Completely  NA

Are any of the inlet structures altered from the original design or otherwise in need of maintenance? (If yes, write in reason: frost heave, vandalism, unknown, etc.)

|       |
|-------|
| Notes |
|       |

Are any trash screens, overflows, or subdrain/underdrains clogged?

No  Partially  Completely  NA

- a. If yes, mark the location on your site map and fill in the boxes below with the cause of the clogging (e.g., debris, sediment, vegetation, etc.)
- b. Are any of the overflow or bypass structures altered from the original design or otherwise in need of maintenance? (if yes, write in reason: frost heave, vandalism, unknown)

|       |
|-------|
| Notes |
|       |





**Vegetation**

- What is the approximate vegetation survival rate? \_\_\_\_\_%
- a. Does the current vegetation match the original design?  
 Yes  No  Unknown
  - b. Is there the presence of:  
 Diseased plants  
 Weeds  
 Noxious weeds  
 None of the above  
 Other: \_\_\_\_\_
  - c. Does the vegetation appear to be healthy?  
 Yes  No (If no, describe below)
  - d. Is the vegetation the appropriate size and density?  
 Yes  No (If no, describe below)
  - e. Does the current vegetation match the original design?  
 Yes  No (If no, describe below)
  - f. Is there the presence of:  
 Diseased plants  
 Weeds  
 Noxious weeds  
 None of the above  
 Other:
  - g. Does the current vegetation match the original design?  
 Yes  No  Unknown
  - h. Does the vegetation appear to be healthy?  
 Yes  No (If no, describe below)

|       |
|-------|
| Notes |
|       |

**Mulch**

Are there any bare spots (without mulch cover) or locations with mulch depth less than 2 inches?  Yes  No  
 If yes, mark on site map









Appendix D: VTA Approved Pesticides





| VTA APPROVED GENERAL USE PESTICIDES   |             |                 |   |                               |                        |   |
|---------------------------------------|-------------|-----------------|---|-------------------------------|------------------------|---|
| Product Name                          | Type        | EPA #/ SF code* | Ingredients                             | Pesticide Hazard Tier**       | Use Limitation Type*** | Use Limitations   |
| Actinovate                            | Fungicide   | 73314-1         | <i>Streptomyces lydicus</i><br>WYEC 108 | Least hazardous<br>(Tier III) | Least Limited          |   |
| Advion Ant Bait Arena (Dupont)        | Insecticide | 352-664         | Indoxacarb 0.1%                         | Least hazardous<br>(Tier III) | Least Limited          |   |
| Advion Ant Gel (Dupont)               | Insecticide | 352-746         | Indoxacarb 0.05%                        | Least hazardous<br>(Tier III) | Least Limited          |   |
| Advion Cockroach Bait Arena (Dupont)  | Insecticide | 352-668         | Indoxacarb 0.5%                         | Least hazardous<br>(Tier III) | Least Limited          |   |
| Advion Cockroach Gel Bait (Dupont)    | Insecticide | 352-652         | Indoxacarb 0.6%                         | Least hazardous<br>(Tier III) | Least Limited          |   |
| Agri-Fos Systemic Fungicide           | Fungicide   | 71962-1         | Potassium phosphite<br>45.8%            | Least hazardous<br>(Tier III) | Least Limited          | For use on high-value Coast Live Oaks ( <i>Quercus agrifolia</i> ) susceptible to <i>Phytophthora</i> , or in experiments with <i>Phytophthora</i> control.   |
| Alligare Rotary 2 SL                  | Herbicide   | 81927-6         | Imazapyr,<br>isopropylamine salt 28%    | More hazardous<br>(Tier II)   | More Limited           | Alternative to Tier I herbicides. Use caution with adjoining desirable vegetation.  |
| Aquamaster (Roundup Custom) Herbicide | Herbicide   | 524-343         | Glyphosate, isopropylamine salt 53.8%   | Most hazardous<br>(Tier I)    | Most Limited           | <b>Subject to "Limitations on most restricted herbicides"</b><br>Other limitations: For aquatic uses, use for emergent plants in ponds, lakes, drainage canals, and areas around water or within watershed areas. |
| Avenger                               | Herbicide   | 82052-1         | d-Limonene 60%                          | Least hazardous<br>(Tier III) | More Limited           | Burndown herbicide. Not for use near water.   |

\*For products exempt from US EPA registration (usually 'Generally Regarded as Safe'), SF creates its own product code.

\*\*A product's tier ranking reflects *hazard* (the possibility of harm) but not *risk* (probability of harm). It does not include consideration of likely exposure.

\*\*\*Use limitation type is an informal rating of *risk* (probability of harm), determined by considering a product's hazard tier rating, formulation, likely exposure, and typical uses.

Excerpt from 2017 San Francisco Reduced-Risk Pesticide List



| VTA APPROVED GENERAL USE PESTICIDES                                    |             |                 |  |                            |                        |  |
|--|-------------|-----------------|--|----------------------------|------------------------|--|
| Product Name   | Type        | EPA #/ SF code* | Ingredients  | Pesticide Hazard Tier**    | Use Limitation Type*** | Use Limitations  |
| <b>xxe</b>   | Herbicide   | 70299-20        | nonanoic acid, 61%   | More hazardous (Tier II)   | More Limited           | Burndown herbicide.  |
| <b>zatin XL</b>  | Insecticide | 70051-27        | Azadirachtin 3%  | Most hazardous (Tier I)    | More Limited           | For greenhouses and established plants for interiorscapes. Do not apply on flowering plants when bees are active. USE UP EXISTING STOCKS - Azatrol is safer alternative. |
| <b>zatrol EC Insecticide</b>   | Insecticide | 2217-836        | Azadirachtin (2328) 1.2%   | More hazardous (Tier II)   | More Limited           | For greenhouses and established plants for interiorscapes. Do not apply on flowering plants when bees are active.  |
| <b>acillus thuringiensis insecticides (excluding mosquito control)</b> | Insecticide | Various         | <i>Bacillus thuringiensis</i> (various subspp.)                              | Least hazardous (Tier III) | Least Limited          |  |
| <b>estYet Cedarcide</b>  | Insecticide | exemptprod- 009 | Cedarwood oil, amorphous silica  | Least hazardous (Tier III) | Least Limited          |  |
| <b>ioLink Buffer &amp; enetrant</b>                                    | Adjuvant    | exemptprod- 010 | Citric acid 20%, garlic extract 7%   | More hazardous (Tier II)   | Least Limited          |  |
| <b>ond Spreader-Sticker</b>  | Adjuvant    | 34704-50033     | Synthetic carboxylated latex 50%, primary aliphatic oxyalkylated alcohol 10% | Least hazardous (Tier III) | Least Limited          |  |
| <b>imexa Insecticide dust</b>  | Insecticide | 73079-12        | Amorphous silica gel 100%  | Least hazardous (Tier III) | Least Limited          | Only for use on rat mites, bedbugs, lice, and yellowjackets in walls when nonchemical techniques prove ineffective.  |

or products exempt from US EPA registration (usually 'Generally Regarded as Safe'), SF creates its own product code.

A product's tier ranking reflects *hazard* (the possibility of harm) but not *risk* (probability of harm). It does not include consideration of likely exposure.

\*Use limitation type is an informal rating of *risk* (probability of harm), determined by considering a product's hazard tier rating, formulation, likely exposure, and typical uses.

cerpt from 2017 San Francisco Reduced-Risk Pesticide List



VTA APPROVED GENERAL USE PESTICIDES

| Product Name                               | Type                | EPA #/ SF code*              | Ingredients   | Pesticide Hazard Tier**       | Use Limitation Type*** | Use Limitations   |
|--|---------------------|------------------------------|---|-------------------------------|------------------------|---|
| 3 Silicone<br>actant                       | Adjuvant            | 1050775-<br>50025 [INACTIVE] | Polymethyl-siloxane,<br>nonionic  | Least hazardous<br>(Tier III) | More Limited           |   |
| 1petitor                                   | Adjuvant            | 2935-50173                   | Ethyl oleate  | Least hazardous<br>(Tier III) | Least Limited          |   |
| serve SC Turf and<br>amental               | Insecticide         | 62719-291                    | Spinosad 11.6%  | More hazardous<br>(Tier II)   | Least Limited          | For use as a last resort in greenhouses. If feasible, alternate<br>with other products to avoid the development of resistance<br>Use on high value ornamentals only.  |
| ter Ridder                                 | Mammal<br>repellant | 50932-10                     | Oil of black pepper 0.48%   | Least hazardous<br>(Tier III) | Least Limited          |   |
| ug Turbo                                   | Nematicide          | 70310-5                      | Fats & glyceridic oils<br>margosa 65.8%, azadirachtin<br>0.7%   | More hazardous<br>(Tier II)   | Least Limited          |   |
| our  | Mammal<br>repellant | exemptprod-015               | White pepper 3%, white<br>mineral oil 87%, silica 10%   | Least hazardous<br>(Tier III) | Least Limited          |   |
| Exempt/Essentria<br>Wasp and Hornet<br>r   | Insecticide         | exemptprod-007               | 2-phenethyl propionate 2%,<br>rosemary oil 3%   | Least hazardous<br>(Tier III) | Least Limited          | Preferred alternative to Wasp Freeze but may not act quick<br>enough during late summer, when yellowjackets are most<br>aggressive. Consider digging up nest and baiting with honey<br>evening to attract raccoons.   |
| tar II Insect Growth<br>ulator (Enstar 5E) | Insecticide         | 2724-476                     | S-kinoprene 64.1%   | More hazardous<br>(Tier II)   | More Limited           | USE UP EXISTING STOCKS. For use only in nurseries and on<br>roses.  |
| entria IC3                                 | Insecticide         | exemptprod-013               | Rosemary oil 10%, geraniol<br>5%, peppermint oil 2%,<br>wintergreen oil, white<br>mineral oil, vanillin,<br>polyglyceryl oleate | Least hazardous<br>(Tier III) | Least Limited          |   |
| ta   | Herbicide           | 67702-26                     | Iron HEDTA 26.52%   | Most hazardous<br>(Tier I)    | More Limited           | USE UP EXISTING STOCKS.   |
| ion 4 Ultra                                | Herbicide           | 62719-527                    | Triclopyr, butoxyethyl ester<br>60.45%  | Most hazardous<br>(Tier I)    | Most Limited           | <b>Subject to "Limitations on most restricted herbicides"</b> Use<br>for targeted treatments of high profile or highly invasive ex<br>via dabbing or injection. May use for targeted spraying only<br>when dabbing or injection are not feasible. HIGH PRIORITY<br>FIND ALTERNATIVE |

products exempt from US EPA registration (usually 'Generally Regarded as Safe'), SF creates its own product code.

product's tier ranking reflects *hazard* (the possibility of harm) but not *risk* (probability of harm). It does not include consideration of likely exposure.

use limitation type is an informal rating of *risk* (probability of harm), determined by considering a product's hazard tier rating, formulation, likely exposure, and typical uses.

pt from 2017 San Francisco Reduced-Risk Pesticide List



| VTA APPROVED GENERAL USE PESTICIDES                                  |             |                 |  |                            |                        |  |
|--|-------------|-----------------|--|----------------------------|------------------------|--|
| Product Name   | Type        | EPA #/ SF code* | Ingredients  | Pesticide Hazard Tier**    | Use Limitation Type*** | Use Limitations  |
| <b>Gentrol Point Source Roach Control Device</b>                     | Insecticide | 2724-469        | Hydroprene 96%   | Least hazardous (Tier III) | Least Limited          |  |
| <b>Habitat</b>   | Herbicide   | 241-426         | Imazapyr, isopropylamine salt, 28%   | More hazardous (Tier II)   | More Limited           | Alternative to Tier I herbicides. Use caution with adjoining desirable vegetation.   |
| <b>Intice Thiquid Ant Bait</b>                                       | Insecticide | 73079-7         | Borax, 5%  | Most hazardous (Tier I)    | Least Limited          |  |
| <b>M-pede Insecticide/Fungicide</b>                                  | Insecticide | 62719-515       | Potash soap 49%  | More hazardous (Tier II)   | More Limited           | Nursery, specialty gardens, and Africanized Honey Bees.  |
| <b>Maxforce FC Magnum Roach Killer Bait Gel</b>                      | Insecticide | 432- 1460       | Fipronil 0.05%   | More hazardous (Tier II)   | More Limited           | Not for use in outdoor areas with potential rain exposure  |
| <b>Maxforce FC Professional Insect Control Ant Bait Stations</b>     | Insecticide | 432-1256        | Fipronil 0.01%   | More hazardous (Tier II)   | More Limited           | Not for use in outdoor areas with potential rain exposure  |
| <b>Maxforce FC Professional Insect Control Roach Bait Stations</b>   | Insecticide | 432-1257        | Fipronil 0.05%   | More hazardous (Tier II)   | More Limited           | Not for use in outdoor areas with potential rain exposure  |
| <b>Maxforce FC Professional Insect Control Roach Killer Bait Gel</b> | Insecticide | 432-1259        | Fipronil 0.01%   | More hazardous (Tier II)   | More Limited           | Not for use in outdoor areas with potential rain exposure  |
| <b>Milestone</b>   | Herbicide   | 62719-519       | Aminopyralid, triisopropanolamine salt (5928) 40.6%                            | More hazardous (Tier II)   | More Limited           | For invasive species in natural areas or parklands where other alternatives are ineffective, especially for invasive legumes and composites such as yellow star thistle and purple star thistle. |
| <b>Milestone VM Plus</b>   | Herbicide   | 62719-572       | Aminopyralid, triisopropanolamine salt, 2%; Triclopyr, triethylamine salt, 16% | More hazardous (Tier II)   | More Limited           | Use only for cut stump or injection  |
| <b>Nufarm Polaris Herbicide</b>                                      | Herbicide   | 228-534         | Imazapyr, isopropylamine salt, 28%   | More hazardous (Tier II)   | More Limited           | Alternative to Tier I herbicides. Use caution with adjoining desirable vegetation.   |

\*For products exempt from US EPA registration (usually 'Generally Regarded as Safe'), SF creates its own product code.

\*\*A product's tier ranking reflects *hazard* (the possibility of harm) but not *risk* (probability of harm). It is does not include consideration of likely exposure.

\*\*\*Use limitation type is an informal rating of *risk* (probability of harm), determined by considering a product's hazard tier rating, formulation, likely exposure, and typical uses.

Excerpt from 2017 San Francisco Reduced-Risk Pesticide List



| VTA APPROVED GENERAL USE PESTICIDES                                       |                  |                 |  |                            |                        |   |
|---|------------------|-----------------|--|----------------------------|------------------------|---|
| Product Name  | Type             | EPA #/ SF code* | Ingredients  | Pesticide Hazard Tier**    | Use Limitation Type*** | Use Limitations   |
| OhYeah!   | Insecticide      | exemptprod-002  | Sodium lauryl sulfate  | Least hazardous (Tier III) | Least Limited          |   |
| Orange Guard  | Insecticide      | 61887-1         | D-limonene 5.8%  | More hazardous (Tier II)   | More Limited           | Soap spray is preferred for removing ant trails. Minimize use in enclosed areas due to scent. Potential aquatic hazard - do not apply directly to water.    |
| Organocide  | Insecticide      | exemptprod-010  | Sesame oil 5%  | Least hazardous (Tier III) | Least Limited          |   |
| Oust XP Herbicide (DuPont)  | Herbicide        | 352-601         | Sulfometuron-methyl 75%  | More hazardous (Tier II)   | Most Limited           | For use only on airport operational areas subject to FAA requirements.  |
| Pentrabark  | Adjuvant         | 83416-50001     | Polyalkyleneoxide modified heptamethyltrisiloxane  | Least hazardous (Tier III) | More Limited           |   |
| Prescription Treatment Brand Perma-Dust                                   | Insecticide      | 499-384         | Boric acid 35%, petroleum distillates-hydrotreated light 10%, HFC-134A, 1,1 difluoroethane | Most hazardous (Tier I)    | More Limited           | Use in situations where adhesion of dust is important and non-aerosol boric acid products are ineffective.  |
| Prescription Treatment Brand Wasp-Freeze Wasp and Hornet Killer Formula 1 | Insecticide      | 499-362         | Phenothrin 12%, d-trans allethrin .129%, CO2   | Most hazardous (Tier I)    | Most Limited           | Use only when a concern for public safety, and in situations where use of EcoExempt product is inadequate or unsafe.  |
| Roundup Promax Herbicide  | Herbicide        | 524-579         | Glyphosate, isopropylamine salt 48.7%  | Most hazardous (Tier I)    | Most Limited           | <b>Subject to "Limitations on most hazardous herbicides"</b> Use of Aquamaster + Competitor is preferred except in situations where rainfastness is needed. |
| Shake-Away Coyote Urine Repellant Granules                                | Mammal repellent | exemptprod-014  | Coyote urine 5%, limestone 95%   | Least hazardous (Tier III) | Least Limited          |   |
| Sluggo Slug and Snail Bait  | Molluscicide     | 67702-3         | Phosphoric acid, iron(3+) salt (1:1) 1%  | Least hazardous (Tier III) | Least Limited          |   |
| Spraytech Oil   | Insecticide      | 65328-50001     | Soybean oil  | More hazardous (Tier II)   | Least Limited          |   |
| Stalker herbicide   | Herbicide        | 241-398         | Imazapyr, isopropylamine salt 28%  | More hazardous (Tier II)   | More Limited           | Alternative to Tier I herbicides. Use caution with adjoining desirable vegetation. USE UP EXISTING STOCK  |

\*For products exempt from US EPA registration (usually 'Generally Regarded as Safe'), SF creates its own product code.

\*\*A product's tier ranking reflects *hazard* (the possibility of harm) but not *risk* (probability of harm). It does not include consideration of likely exposure.

\*\*\*Use limitation type is an informal rating of *risk* (probability of harm), determined by considering a product's hazard tier rating, formulation, likely exposure, and typical uses.

Excerpt from 2017 San Francisco Reduced-Risk Pesticide List



| VTA APPROVED GENERAL USE PESTICIDES  |             |                 |                                     |                         |                        |                 |
|--|-------------|-----------------|-------------------------------------|-------------------------|------------------------|-----------------|
| Product Name   | Type        | EPA #/ SF code* | Ingredients                         | Pesticide Hazard Tier** | Use Limitation Type*** | Use Limitations |
| Terro Ant Killer II, Terro Ant Killer II Liquid Ant Baits, Terro-PCO Liquid Ant Bait | Insecticide | 149-8           | Sodium tetraborate decahydrate 5.4% | Most hazardous (Tier I) | Least Limited          |                 |

\*For products exempt from US EPA registration (usually 'Generally Regarded as Safe'), SF creates its own product code.  
 \*\*A product's tier ranking reflects *hazard* (the possibility of harm) but not *risk* (probability of harm). It does not include consideration of likely exposure.  
 \*\*\*Use limitation type is an informal rating of *risk* (probability of harm), determined by considering a product's hazard tier rating, formulation, likely exposure, and typical uses.  
 Excerpt from 2017 San Francisco Reduced-Risk Pesticide List





| VECTOR CONTROL PRODUCTS                         |                              |                 |   |                            |                        |   |
|---|------------------------------|-----------------|---|----------------------------|------------------------|---|
| Product Name                                    | Type                         | EPA #/ SF code* | Ingredients   | Pesticide Hazard Tier**    | Use Limitation Type*** | Use Limitations   |
| <b>Agnique MMF-G</b>                            | Mosquito control - other     | 7969-333        | Poly(oxy-1,2-ethanediyl),alpha-isodecyl-omega-hydroxy-phosphate 32%                   | More hazardous (Tier II)   | More Limited           | Use for late instar mosquito larvae and pupae, in combination with microbial products. USE UP REMAINING STOCK   |
| <b>BVA2 Mosquito Larvicide</b>                  | Mosquito control - other     | 70589-1         | Highly refined petroleum distillate (mineral oil)                                     | More hazardous (Tier II)   | More Limited           | Use as a pupacide for public health mosquito treatments.  |
| <b>Confrac All-Weather Blox</b>                 | Rodenticide                  | 12455-79        | Bromadiolone 0.005%   | Most hazardous (Tier I)    | Most Limited           | HIGH PRIORITY FOR REMOVAL. USE UP EXISTING STOCKS. For use only in San Francisco International Airport Terminal Areas, or for commercial lessees on city properties that are not adjacent to natural areas. In commercial establishments, use of product shall be a last resort after other, less-toxic measures have been implemented, including sanitation and trapping, and <b>only where a significant public health hazard is recognized by the SF Dept. of Public Health.</b> In all cases, monitoring shall be used whenever feasible to minimize rodenticide use. |
| <b>Mosquito control - microbial</b>             | Mosquito control - microbial | Various         | <i>Bacillus thuringiensis</i> (Berliner or Israelensis) or <i>Bacillus sphaericus</i> | Least hazardous (Tier III) | Least Limited          | Any microbial mosquito larvicide with active ingredients <i>Bacillus thuringiensis</i> (Berliner or Israelensis) or <i>Bacillus sphaericus</i> is categorized as Least limited.   |
| <b>Mosquito control products - IGRs</b>         | Mosquito control - IGRs      | Various         | <i>S-Methoprene (5026)</i>  | Least hazardous (Tier III) | More Limited           | Use for tanks with limited access, or other areas where frequent treatments are infeasible. For City catchment basins, microbial products are preferred. Not for use in estuarine environments except under control of San Mateo Mosquito Abatement District.   |
| <b>Rodent control - diphacinone block baits</b> | Rodenticide                  | Various         | <i>Diphacinone</i>  | More hazardous (Tier II)   | More Limited           | See Site-Specific Limitations. For rat control only in situations with high public health concerns, where trapping is infeasible. In all cases, monitoring shall be used whenever feasible to minimize rodenticide use. HIGH PRIORITY TO FIND ALTERNATIVE.  |

\*For products exempt from US EPA registration (usually 'Generally Regarded as Safe'), SF creates its own product code.

\*\*A product's tier ranking reflects *hazard* (the possibility of harm) but not *risk* (probability of harm). It does not include consideration of likely exposure.

\*\*\*Use limitation type is an informal rating of *risk* (probability of harm), determined by considering a product's hazard tier rating, formulation, likely exposure, and typical uses.

Excerpt from 2017 San Francisco Reduced-Risk Pesticide List



| VECTOR CONTROL PRODUCTS                           |             |                 |                          |                         |                        |  |
|---|-------------|-----------------|--------------------------|-------------------------|------------------------|--|
| Product Name                                      | Type        | EPA #/ SF code* | Ingredients              | Pesticide Hazard Tier** | Use Limitation Type*** | Use Limitations  |
| <b>Top Gun All Weather Bait Block Rodenticide</b> | Rodenticide | 67517-66        | <i>Bromethalin 0.01%</i> | Most hazardous (Tier I) | Most Limited           | For use only in City-owned sewer lines, San Francisco International Airport Terminal Areas, or for commercial lessees on city properties that are not adjacent to natural areas. In commercial establishments, use of product shall be a last resort after other, less-toxic measures have been implemented, including sanitation and trapping, and only where a significant public health hazard is recognized by the San Francisco Dept. of Public Health. In all cases, monitoring shall be used whenever feasible to minimize rodenticide use. |

\*For products exempt from US EPA registration (usually 'Generally Regarded as Safe'), SF creates its own product code.

\*\*A product's tier ranking reflects *hazard* (the possibility of harm) but not *risk* (probability of harm). It does not include consideration of likely exposure.

\*\*\*Use limitation type is an informal rating of *risk* (probability of harm), determined by considering a product's hazard tier rating, formulation, likely exposure, and typical uses.

Excerpt from 2017 San Francisco Reduced-Risk Pesticide List



**ATTACHMENT M:**

VTA SWPPP SPECIFICATION TEMPLATES



*Project Name*  
*Contract C#XXXXX*

---

**SECTION 01 57 23**

**TEMPORARY WATER POLLUTION CONTROL**

**Designer instructions are indicated in blue highlights.**

*Text to be customized is shown in red text.*

**PART 1 – GENERAL**

**1.01 SECTION INCLUDES**

- A. This Section includes requirements for National Pollutant Discharge Elimination system (NPDES) construction water pollution control including Best Management Practices (BMPs), maintenance, erosion, sediment control, dust control, and waste management.
- B. This section identifies stormwater pollution prevention measures that will be implemented before, during, and after construction to avoid, reduce, or minimize water quality impacts due to the project.
- C. Contractor will be responsible for any work stoppages and will be expected to complete all work as specified elsewhere in these special provisions.
- D. Water pollution control maintenance work and Storm Water Pollution Prevention Plan (SWPPP) must be considered as integral functional practices to implement water pollution control.
- E. Failure to fully comply with the requirements of the applicable NPDES permits must subject the Contractor to all fines, damages and job delays incurred due to failure to implement the SWPPP.

1.02 Error! Reference source not found.

*Attachment G Environmental Coordination and Cooperation*  
*01 31 31 UTILITY COORDINATION*  
*01 35 29 HAZARDOUS MATERIALS ACCIDENT PREVENTION*  
*01 35 70 ENVIRONMENTAL REQUIRMENTS*  
*01 35 74 SUSTAINABILITY PLAN*  
*01 35 95 PUBLIC INFORMATION AND COMMUNITY RELATIONS*  
*01 43 00 QUALITY ASSURANCE*  
*01 45 00 QUALITY CONTROL*  
*01 55 27 MAINTENANCE OF TRAFFIC AND ACCESS*  
*01 56 16 DUST CONTROL*  
*01 74 00 CLEANING*  
*01 57 00 TEMPORARY CONTROLS*  
*01 71 24 PRECONSTRUCTION SURVEYS*  
*01 71 43 PERMITS, LICENSES, AND AGREEMENTS*  
*01 74 21 WASTE MANAGEMENT*  
*01 74 25 CONTAMINANT MANAGEMENT*  
*01 75 00 PRESERVATION AND RESTORATION*  
*01 77 00 CLOSEOUT PROCEDURES*  
*01 78 23 OPERATION AND MAINTENANCE DATA*  
*01 78 39 PROJECT RECORD DOCUMENTS*  
*01 79 00 TRAINING*



*Project Name*  
*Contract C#XXXXX*

02 41 00 DEMOLITION  
02 41 10 TREE PROTECTION AND REMOVAL  
03 05 15 PORTLAND CEMENT CONCRETE  
22 14 01 STORM DRAINAGE  
31 00 00 EARTHWORK  
31 11 00 CLEARING AND GRUBBING  
31 23 19 DEWATERING  
31 23 43 STRUCTURE EXCAVATION AND BACKFILL  
31 32 00 HYDROSEEDING  
31 35 00 SLOPE PROTECTION  
31 62 00 DRIVEN PILES  
31 63 29 DRILLED CONCRETE PIERS AND SHAFTS  
32 90 00 PLANTING  
33 40 00 STORM DRAINAGE UTILITIES  
33 41 13 STORM DRAINAGE  
33 46 00 OUTFALL PROTECTION

1.03 **REGULATORY REQUIREMENTS**

Designer to include the permits that are relevant, depending on the projects activities that will be performed, water quality/discharge point for any water and the right-of-way impacted.

Pursuant to the applicable laws and requirements for water pollution control during construction of the project until regulatory approval of construction stormwater permit termination, including but not limited to:

- A. State Water Resources Control Board (SWRCB) Order No. R2-2009-0009-DWQ, NPDES General Permit No. CAS000002, Storm Water Discharges Associated with Construction and Land Disturbance Activities, September 2, 2009., (hereafter Construction General Permit or CGP). Refer also to Appendices.
- B. Insert reference to CGP Preliminary Draft and indicate that if it is adopted as final during the bid and award, note that the new permit's provisions will be considered as included at bid time.
- C. Only include if Caltrans ROW will be impacted: The Caltrans Permit No. CAS000003 for Storm Water Discharges Associated with the State of California Department of Transportation adopted by the State Water Resources Control Board on September 19, 2012 as Order No. 2012-0011-DWQ.
- D. Only include if City/County/SCVWD or other Municipal Regional Permittee's ROW will be impacted: California Regional Water Quality Control Board (RWQCB) – Region 2, Order No. R2-2015-0049, NPDES Permit No. CAS612008, San Francisco Bay Region Municipal Regional Storm water NPDES Permit, November 19, 2015 for Municipal Separate Storm Water Discharges Associated with jurisdictions and entities permitted under the San Francisco Bay Municipal Regional (hereafter Municipal Regional Permit or MRP). Refer also to the Santa Clara Valley Urban Runoff Pollution Prevention Program (SCVURPPP), C.3 Storm water Handbook, latest version and addendum.
- E. State Water Resources Control Board (SWRCB) – Order No. 2013-001-DWO, NPDES Permit No. CAS000004, Waste Discharge Requirements for Storm Water Discharges form Small Municipal Separate Storm Sewer System (MS4s) February 5, 2013 (hereafter Small Phase II Permit).



*Project Name*  
*Contract C#XXXXXX*

- F. All applicable National Pollutant Discharge Elimination System (NPDES) permits required by the California Environmental Protection Agency, delegated to the State Water Resource Control Board and/or Regional Water Quality Control Board (RWQCB)s related to activity-specific requirements such as dewatering, VOC-impacted groundwater extraction and treatment, etc.
- G. California Storm water Quality Association (CASQA) Stormwater Best Management Practice Online Handbook: Construction (hereafter CASQA handbook, available online at CASQA.org).
- H. Caltrans Construction Site Best Management Practices (BMP) Manual CTSW-RT-17-314.18.1 May 2017 (hereafter Caltrans handbook, available online at dot.ca.gov).

1.04 **MEASUREMENT AND PAYMENT**

- A. Full compensation for conforming to the requirements of this section will be paid for as described in the various associated bid items in the Schedule of Quantities and Prices (SQP), and as follows:

- B. **SWPPP Preparation**

The contract lump sum price paid for SWPPP Preparation must include furnishing all labor materials, tools, equipment, and incidentals and for doing all the work involved in preparing, obtaining approval of, revising, and amending the SWPPP as specified in these technical specifications, and as directed by VTA. For the pay item “SWPPP Preparation”, contractor will receive 0% of the pay item for submittal of the SWPPP or if VTA identifies “Amend and Resubmit”, 50% of the pay item if VTA identifies “Make Correction Noted”, and 100% of the pay item if VTA identifies “No Exception Taken”

- C. **Amend SWPPP**

For the pay item “Amend SWPPP”, contractor will receive 0% of the pay item for submittal of the SWPPP Amendment or if VTA identifies “Amend and Resubmit”, 50% of the pay item if VTA identifies “Make Correction Noted”, and 100% of the pay item if VTA identifies “No Exception Taken”. For any amendment not transmitted to VTA within 14 days of request, VTA will deduct from the pay item. Refer to Section 7 for details on special withholding.

- D. **SWPPP Inspections**

The pay item “SWPPP Inspections” includes furnishing all labor materials, tools, equipment, and incidentals and for doing all the work involved in preparing, obtaining approval of, revising, and amending the SWPPP inspections as specified in these technical specifications, and as directed by VTA. Inspections are captured in CloudCompli software platform within 24-hours of inspection, and formally submitted to VTA weekly. VTA will deduct from the pay item for any inspections not performed and documented per the CGP, these technical specifications or for any reports not entered into CloudCompli within 24-hours, or not formally submitted in a timely fashion (i.e., within the pay period in which they occurred). Refer to Section 7 for details on special withholding.

- E. **Rain Event Action Plan (REAP) Reporting** Note that RL1 and LUP projects do not require REAPs, only RL2 and 3. REAPs are to be estimated **per rain event, not every day of rain.**

The contract price paid per each for “REAP Reporting” includes furnishing all labor materials, tools, equipment, and incidentals and for doing all the work involved in preparing, obtaining approval of, revising, and amending the SWPPP inspections as specified in these technical



*Project Name*  
*Contract C#XXXXX*

specifications, and as directed by VTA. Inspections are captured in CloudCompli software platform within 24-hours of inspection, and formally submitted to VTA weekly. VTA will deduct from the pay item for any inspections not performed and documented per the CGP, these technical specifications or for any reports not entered into CloudCompli within 24-hours, or not formally submitted in a timely fashion (i.e., within the pay period in which they occurred). Refer to Section 7 for details on special withholding.

- F. Stormwater Sampling and Ad Hoc Storm Water Multiple Application and Report Tracking System (SMARTS) Reporting **Note that Risk Level 1 projects (RL1) will only need As Hoc sampling of spills/non-stormwater discharges, and RL2 will require sampling for every day of rain.**

The contract price paid per each for Stormwater Sampling and Ad Hoc SMARTS Reporting must include furnishing all labor materials, tools, equipment, and incidentals and for doing all the work involved in monitoring, sampling and analysis for storm water runoff as specified in these technical specifications, and as directed by VTA. Contractor will receive 100% of the pay item for “Stormwater Sampling and Ad Hoc SMARTS Reporting” if contractor completes sampling and uploads sampling data into SMARTS within 24 hours of receiving sampling results. VTA will deduct from the pay item for any sampling not performed or for any data submission not performed within a pay period. Refer to Section 7 for details on special withholding.

- G. Stormwater Annual Report

The contract price paid per each for Stormwater Annual Report must include furnishing all labor materials, tools, equipment, and incidentals and for doing all the work involved in preparing and uploading to SMARTS of the Stormwater Annual Report as specified in these technical specifications, and as directed by VTA. Contractor will complete a CGP Annual Report for each year of work that occurs within a CGP permit year, defined as July 1st-June 30th. Contractor will receive 50% of the pay item for “Stormwater Annual Report” after VTA approves the contract submittal of the Stormwater Annual Report with a “No Exceptions Taken” dispensation, and 100% of the pay item upon certification of the CGP Annual Report in SMARTS. VTA will deduct from the pay item for any Annual Report submittal that is not submitted to VTA by July 15th and uploaded by Contractor into SMARTS by August 1st of each year. Refer to Section 7 for details on special withholding.

- H. Notice of Termination (NoT)

Contractor will receive 50% of the pay item for “Notice of Termination” after VTA approves the contract submittal of the Notice of Termination with a “No Exceptions Taken” dispensation, and 100% of the pay item for “Notice of Termination” after the Notice of Termination is certified in SMARTS. VTA will deduct from the pay item for any Notice of Termination submission that is not uploaded into SMARTS, by the contractor, within 14 days of the VTA’s request. Refer to Section 7 for details on special withholding.

**Designer to estimate all of the below quantities as outlined in the VTA Design Criteria Manual for Stormwater, Planting, and Irrigation (VTA DCM). Customize the Measurement and Payment section to only include the applicable BMPs and items.**

- I. Construction Site Management

The contract lump sum price paid for Construction Site Management must include furnishing all labor, materials, tools, equipment, and incidentals, and for doing all the work involved in construction site management including but not limited to run-on run-off controls, rock bags, spill



*Project Name*  
*Contract C#XXXXX*

---

prevention and control, material management, waste management, non-stormwater management, and dewatering activities, as specified in these technical specifications, and as directed by VTA.

J. Temporary Cover

The contract price paid per lump sum for Temporary Cover must include furnishing all labor materials, tools, equipment, and incidentals and for doing all the work involved in installing, maintaining, removing and disposal of Temporary Covers as shown on the Plans, as specified in these technical specifications, and as directed by VTA.

K. Erosion Control Blanket (and/or Temporary) Designer to cross reference WPCDs and incorporate relevant Text:

Erosion Control Blanket will be measured by the square foot. The area will be calculated on the basis of actual or computed slope measurements. The contract price paid per square foot includes full compensation for furnishing all labor, materials, tools, equipment, and incidentals, and for doing all the work involved in installing Erosion Control Blanket, complete in place and removal of Temporary Erosion Control Blanket, as shown on the Plans, as specified in these technical specifications, and as directed by VTA.

L. Temporary Hydraulic Mulch

The contract price paid per square yard for Temporary Hydraulic Mulch must include furnishing all labor materials, tools, equipment and incidentals and for doing all the work involved in installing, maintaining, removing and disposal of temporary hydraulic mulch as shown on the Plans, specified in these technical specifications, and as directed by VTA.

M. Erosion Control (Hydroseed)

Erosion control (hydroseed) will be measured by the square foot. The area will be calculated on the basis of actual or computed slope measurements. The contract price paid per square foot for erosion control (hydroseed) includes full compensation for furnishing all labor, materials, tools, equipment, and incidentals, and for doing all the Work involved in erosion control (hydroseed) complete in place, as shown on the Plans, as specified in these technical specifications, and as directed by VTA.

N. Temporary Drainage Inlet Protection.

The contract price paid per unit for Temporary Drainage Inlet Protection must include furnishing all labor materials, tools, equipment, and incidentals and for doing all the work involved in installing, maintain, removing and disposal of temporary drainage inlet protection as shown on the Plans, specified in these technical specifications, and as directed by VTA. Deduct from the pay item for any DI protection that is not placed, replaced, or not maintained in a timely fashion (i.e., within 14 days of a VTA request).

O. Temporary Perimeter Protection

The contract price paid per linear feet for Temporary Perimeter Protection measured along the centerline of the installed strip for hard surfaces include full compensation for furnishing all labor, materials, tools, equipment, and incidentals, and for doing all the work involved in installing the Temporary Perimeter Protection, complete in place, including maintenance, and in these special provisions, and as directed by VTA. Where Temporary Perimeter Protection segments are joined





*Project Name*  
*Contract C#XXXXX*

---

and overlapped, the overlap will be measured as a single installed strip.

P. Temporary Construction Entrance

Temporary construction entrance will be paid per each. The price for Temporary Construction Entrance includes full compensation for furnishing all labor, materials, tools, equipment, and incidentals, and for doing all the Work involved in constructing temporary construction entrance, complete in place, including removal of temporary construction entrance, as shown on the Plans, these technical specifications, and as directed by the VTA.

No additional compensation will be made if the temporary construction entrance is relocated during the course of construction.

Q. Street Sweeping

The contract lump sum price for Street Sweeping must include furnishing all labor materials, tools, equipment (Sweepers shall be self-loading, motorized, and shall have spray nozzles and vacuum apparatus, dry brooming is not permitted.), and incidentals and for doing all the work involved in street sweeping as specified in these technical specifications, and as directed by VTA.

R. Temporary Concrete Washout

The contract lump sum for Temporary Concrete Washout must include furnishing all labor materials, tools, equipment, and incidentals and for doing all the work involved in installing, maintaining, removing and disposal of temporary concrete washout as shown on the Plans, specified in these technical specifications, and as directed by VTA. One washout/300 yards of concrete will be required at a minimum.

Designer to either include dewatering in this section along with discharge point(s), requirements for turbidity removal and treatment required, or include a separate spec section as illustrated here. Confirm dewatering approach with VTA Compliance Officer.

S. See Section 31 23 19 Dewatering.

T. Other Items

All other items of temporary controls will not be paid for separately but will be considered incidental to the work.

1.05 REFERENCES STANDARDS

1.06 ABBREVIATIONS, ACRONYMS, AND DEFENTIONS Designer to cross reference acronyms and terms that are used in this Section and customize as needed

Abbreviations:

ATS Active Treatment System

BMP Best Management Practices

CASQA California Stormwater Quality Association COI Change of Information



*Project Name*  
*Contract C#XXXXX*

---

|        |   |                                     |  |
|--------|---|-------------------------------------|--|
| CPESC  | Certified Professional in Erosion and Sediment Control™     | CPSWQ                               | Certified Professional in Storm Water Quality™ |
| CWA    | Clean Water Act   |                                     |  |
| LUP    | Linear Underground/Overhead Project MDL                     | Method Detection Limit              |  |
| MS4    | Municipal Separate Storm Sewer System NAL                   | Numeric Action Level                |  |
| NEL    | Numeric Effluent Limitation                                 |                                     |  |
| NOI    | Notice of Intent  |                                     |  |
| NOT    | Notice of Termination                                       |                                     |  |
| NTU    | Nephelometric Turbidity Unit                                |                                     |  |
| NPDES  | National Pollutant Discharge Elimination System             |                                     |  |
| QSD    | Qualified SWPPP Developer                                   |                                     |  |
| QSP    | Qualified SWPPP Practitioner REAP                           | Rain Event Action Plan              |  |
| RUSLE  | Revised Universal Soil Loss Equation                        |                                     |  |
| RWQCB  | Regional Water Quality Control Board                        |                                     |  |
| SDS    | Safety Data Sheet   |                                     |  |
| SMARTS | Storm Water Multiple Application and Report Tracking System |                                     |  |
| SSC    | Suspended Sediment Concentration                            |                                     |  |
| STE    | Standard Taxonomic Effort SWRCB                             | State Water Resources Control Board |  |
| WDID   | Waste Discharge Identification Number                       |                                     |  |

**Definitions:**

**Active Treatment System** – A treatment system that employs chemical coagulation, chemical flocculation, or electrocoagulation to aid in the reduction of turbidity caused by fine suspended sediment.

**Beneficial Uses** – As defined in the California Water Code, beneficial uses of the waters of the state that may be protected against quality degradation include, but are not limited to, domestic, municipal, agricultural, and industrial supply; power generation; recreation; aesthetic enjoyment; navigation; and preservation and enhancement of fish, wildlife, and other aquatic resources or preserves.

**Effluent** – Any discharge of water by a discharger either to the receiving water or beyond the property boundary controlled by the discharger.

**Inactive Construction** – Areas of construction activity that are not active and those that have been



*Project Name*  
*Contract C#XXXXX*

---

active and are not scheduled to be re-disturbed for at least 14 calendar days.

Likely precipitation event – A likely precipitation event is any weather pattern that is forecast to have a 50% or greater probability of producing precipitation in the project area. Obtain likely precipitation forecast information from the National Weather Service Forecast Office by entering the zip code of the project’s location at <http://www.srh.noaa.gov/>.

Non-storm Water Discharges – Discharges that do not originate from precipitation events. They can include, but are not limited to, discharges of process water, vehicle wash water, sanitary wastes, concrete washout water, paint wash water, irrigation water, or pipe testing water.

Qualifying Rain Event – Any event that produces 0.5 inches or more precipitation within a 48 hour or greater period between rain events.

1.07 **SUBMITALS**

A. SWPPP Preparation:

1. Contractor’s Qualified SWPPP Developer (QSD) will prepare the SWPPP using the CASQA SWPPP template format included in the BMP Handbook Portal for a Traditional Risk Level 2 Project. All CASQA recommended language will be included in the SWPPP and customized for the project.
2. Construction cannot commence until a Notice of Intent (NOI) has been submitted through SMARTS, application fee paid by VTA, and a Waste Discharge Identification Number (WDID) has been issued.
3. The SWPPP will describe the methods of temporary or permanent erosion control that will be implemented to stabilize permanent, temporary, and on-going work. Water pollution control measures and temporary erosion control work will be used year-round and during all phases of construction.
4. The SWPPP will include Water Pollution Control Plans (WPCP):
  - Contractor will prepare WPCP to show the site conditions, drainage, and water pollution control components at various phases of construction as specified and as required in the permit. At a minimum, the WPCP will include:
    - The current stage and phase of construction and all other planned improvements. Individual drainage watersheds with the acreage of each watershed will be shown on the plans.
    - All exposed graded surfaces, finished and unfinished construction slopes, stockpiles, haul roads and storage areas, top and toe of slope lines and drainage arrows will be graphically shown.
    - Drainage patterns within each watershed area (shown by slope arrows) and the drainage system or containment area where runoff will be conveyed for removal or storage. Drainage swales, temporary culverts, active and inactive drainage inlets, gutters, and dikes will be clearly shown at a minimum as well as where offsite water enters or exits the site, along with uniquely named or numbered sampling point locations.
  - Locations where offsite run-on to the Work area and where runoff leaves the work area.



*Project Name*  
*Contract C#XXXXX*

- 
- Contractor will identify, as minimum, storage facilities, concrete washout areas and proposed stockpile locations.
  - Water pollution control BMPs will also be shown and may consist of providing drainage inlet protection around or temporarily capping selected drainage systems within areas of active construction. Contractor will monitor the weather forecast to anticipate if inclement weather is approaching. Uncapping drainage inlets and providing measures to trap sediment will be installed prior to the storm. Contractor will maintain BMPs as required during and after the storm event.
  - Any additional requirements of the CGP as referenced elsewhere in this Section and not covered in the above noted items.
5. Contractor's QSD will amend the SWPPP, graphically and in narrative form, whenever there is a change in construction activities or operations which may affect the discharge of significant quantities of pollutants to surface waters, ground waters, municipal storm drain systems, whenever there is a change in disturbed area, and/or when deemed necessary by VTA. The SWPPP will be amended if, at any time, the implementation of the SWPPP is not effectively achieving the objective of compliance with the CGP. Amendments will show additional control measures or revised operations, including those in areas not shown in the initial SWPPP, which are required on the project to control water pollution effectively. In emergency situations that require immediate changes at the Worksite, Contractor's QSP will implement the necessary measures based on verbal instructions of the QSD.
- B. **Designer to confirm whether dewatering will be addressed in this section and not in a separate dewatering spec. Before dewatering, the Contractor will submit a dewatering and discharge work plan. The dewatering and discharge work plan will include:**
1. Title sheet and table of contents.
  2. Description of dewatering and discharge activities detailing locations, quantity of water, equipment, and discharge point.
  3. Estimated schedule for dewatering and discharge start and end dates of intermittent and continuous activities.
  4. Discharge alternatives, such as dust control or percolation.
  5. Visual and quantitative monitoring procedures (such as turbidity and pH monitoring in accordance with the CGP) with inspection log.
  6. Copy of written approval to discharge into a sanitary sewer system at least 7 days before starting discharge activities.
- C. The Contractor will submit the following:
1. Material Safety Data Sheet at least 7 days before material is used or stored.

## **PART 2 PRODUCTS (NOT USED)**



*Project Name*  
*Contract C#XXXXX*

---

**PART 3 EXECUTION**

- A. SWPPP. This section covers work necessary for compliance with the CGP for a **Traditional/Linear Underground/Overhead Risk Level 1/2/3 or Type 1/2/3 Project.**
1. Contractor will comply with the provisions of the National Discharge Elimination System, General Permit No. CAS000002 for Waste Discharge Requirements for Discharges of Storm Water Runoff Associated with Construction Activity adopted by the State Water Resources Control Board on September 2, 2009 as Order No. 2009-0009-DWQ, effective July 1, 2010 (CGP).
  2. VTA as the Legally Responsible Party under the CGP, owner of the site where the subject construction activity will occur, is responsible for obtaining coverage under the CGP. For this purpose, VTA must submit a completed Notice of Intent form, prior to initiation of construction, to the California State Water Resources Control Board, and pay the applicable fee.
  3. VTA will provide review comments within five working days of receipt of Contractor's SWPPP submittal.
  4. Contractor will return a final SWPPP submittal to VTA within five working days of receipt of VTA's comments. These documents will be in conformance with the requirements and conditions set forth in the CGP.
  5. A Notice to Proceed will not be issued by VTA without the express written approval of the SWPPP by VTA and a WDID issuance from the SWRCB. Refer to the Follow-up Letter to the Notice of Award for other submittals required for a Notice of Award.
  6. Contractor will identify in the SWPPP the specific BMPs it proposes to use in connection with the performance of Work under this Contract. Contractor will use applicable BMPs included in the latest edition of the Construction BMP Handbook.
  7. In addition, contractor will indicate nearby work locations covered by other contractors' plans (if applicable) and how coordination is to be accomplished.
  8. Contractor will keep a copy of the approved SWPPP on site at all times and will make it available to governing officials immediately upon request.
  9. Contractor will allow adequate time for review and approval of SWPPP Amendments. Contractor must receive approval from VTA for any SWPPP Amendment prior to implementation. Contractor will submit SWPPP Amendment(s) not later than 10 days prior to a scheduled change in construction operations/new Stage or Phase of construction, within 10 calendar days of any request by VTA, or within 10 calendar days of any change in storm water conditions which affects the discharge of pollutants into surface waters, groundwater, or storm sewer systems. At a minimum, the SWPPP will be amended annually between September 1st and September 15th of each year, showing how the site will be prepared for rain.
  10. Contractor is advised that preparation and implementation of an approved SWPPP does not relieve Contractor of compliance with other State, County, and local governments' regulations including those relating to storm water management or non-point source runoff controls.
  11. Control dust in accordance with Section **01 56 16, Dust Control.**



*Project Name*  
*Contract C#XXXXX*

- 
12. Clean the site in accordance with Section 01 74 00, **Cleaning**.
- B. SWPPP Inspections, Stormwater Sampling, and Ad Hoc SMARTS Reporting
1. All SWPPP Inspections will be captured in the CloudCompli (www.cloudcompli.com) inspection software within 24-hours of performing the inspection, and inspection documentation will be formally submitted to VTA weekly. Contractor will purchase CloudCompli licenses **at a cost of \$1,200 per user per year from CloudCompli (Designer to confirm cost with VTA compliance Officer)** as necessary to meet this requirement, so they can be given a log-on identification and password to access the VTA's CloudCompli project dashboard.
  2. All inspections, daily visual monitoring of track-out and trash areas, and BMP inspections before and after a storm event, are required to be conducted in CloudCompli.
  3. All deficiencies must be corrected within 72-hours.
  4. The Contractor's QSP shall prepare a REAP and conduct pre-storm event inspection within 48 hours of a predicted (greater than 50 percent chance) storm event as defined by the CGP; this inspection must include photographic documentation. The REAP must be submitted in CloudCompli and as a formal submittal as outlined elsewhere in this Section.
  5. Contractors will designate a Data Submitter who will upload all sampling data into the SWRCB online SMARTS system within 24 hours of performing the pH and turbidity sampling or obtaining discharge sampling data from a laboratory. In addition, the Data Submitter will upload any other permit-required data into the SMARTS for the project duration.
  6. Contractor will submit a draft CGP Annual Report to VTA in Microsoft Word format by July 15<sup>th</sup> or 7 days prior to the final punch list walk. Contractor will incorporate VTA comments into the final Annual Report and upload the final Annual Report in SMARTS by August 1st of each year or within 7 days of the lasted charged day.
  7. Contractor is required to prepare and submit a NoT to VTA at project completion. After the contract submittal is approved, the contractor will upload the NoT into SMARTS for VTA certification.

**Designer to customize all of the below BMPs as outlined in the VTA Design Criteria Manual for Stormwater, Planting, and Irrigation (VTA DCM). Customize this section to only include the applicable BMPs and items.**

- C. **Construction Site Management:**
1. **Keep materials or waste storage areas clean, well-organized, and equipped with enough cleanup supplies for the material being stored.**
  2. **Implement spill and leak prevention procedures for chemicals and hazardous substances stored on the job site. All associated cleanup costs and related liability for spilled or leaked chemicals or hazardous substances at the job site are the responsibility of the Contractor.**
  3. **Report minor, semi-significant, and significant or hazardous spills to the VTA immediately.**
  4. **As soon as it is safe, contain and clean up spills of petroleum materials and sanitary and septic waste substances listed under 40 CFR, Parts 110, 117, and 302.**



*Project Name*  
*Contract C#XXXXX*

- 
5. Conduct construction operations in a manner that will minimize pollution of the environment surrounding the area of the Work by all practicable means and methods. Apply specific controls as specified in the Contract Specifications and as follows:
    - a. **Waste Materials:** No waste or eroded materials will be allowed to enter natural or man-made water or sewage removal systems. Eroded materials from excavations, borrow areas, or stockpiled fill will be contained within the Work area. The Contractor will develop methods for control of erosion.
    - b. **Burying:** No burying of waste materials and debris will be permitted.
  6. Provide for and maintain the flow of all sewers, drains, building or inlet connections, and all water courses which may be encountered during progress of the Work. Do not allow the contents of any sewer, drain, or building or inlet connection to flow into trenches. Immediately remove from proximity of the Work all offensive matter, using such precautions as are required by local authorities having jurisdiction.
  7. The Contractor will prevent erosion of excavated areas, embankments, stockpiled earth materials, and other erodible areas, and will provide control of runoff sediment from siltation and pollution of the drainage systems.
  8. Prevent erosion of excavated areas, embankments, stockpiled earth materials, and other erodible construction areas, and prevent pollution of drainage systems by diversion of storm runoff around construction activities or by trapping or retaining sediment delivered by storm runoff.
  9. Provide control of construction operations so that sediment or siltation will not be introduced into the drainage systems from storm runoff.
  10. If the earthwork/paving in any area has not progressed to a point where all or part of the facilities on the SWPPP for that area can be constructed, Contractor will construct such supplementary temporary erosion control facilities as are necessary to protect adjacent private and public property at all times.
  11. Water pollution control measures will be constructed and functioning to prevent water pollution from areas where portions of the Contract have been completed and no further earthwork/paving is planned.
  12. All egress from the site will be maintained in a dry condition, and any sediment tracked onto streets, sidewalks, or drives will be immediately removed, and the affected area will be cleaned. VTA may order such work at any time the conditions warrant.
  13. All trucks coming to the jobsite or leaving the jobsite with materials or loose debris will be loaded in a manner that will prevent dropping of materials or debris on streets. Spillage resulting from hauling operations along or across any public traveled way will be removed immediately.
  14. Dust palliative will conform to the provisions in 01 57 00, Temporary Controls, of these technical specifications
- D. Temporary Cover
1. Protect stockpiled materials to prevent erosion and exposure of stormwater to pollutants.



*Project Name*  
*Contract C#XXXXX*

- 
- E. Erosion Control Blanket
1. Erosion Control Blanket shall conform to the provisions of Section 13, Water Pollution Control, and Section 21, Erosion Control, of the State of California 2018 Standard Specifications and to these technical specifications or as directed by VTA.
  2. Erosion Control Blanket shall be furnished and installed, as specified in the technical specifications, as shown on The Plans and at the locations designated by VTA
  3. Monofilament plastic mesh shall not be used.
  4. Temporary blanket shall be installed at locations to control erosion on critical areas of unfinished earthwork slopes.
  5. When no longer required for the purpose as determined by VTA, temporary blanket shall be abandoned or removed as directed by VTA.
- F. Temporary Hydraulic Mulch
1. Temporary Bonded Fiber Matrix
  2. Fiber for temporary bonded fiber matrix shall be 100 percent wood fiber and shall comply with the requirements in Section 21-1.02E "Fiber" of the State of California 2018 Standard Specifications except the sieve requirement must be at least 50 percent retained on a no. 25 sieve.
  3. Temporary Tacked Straw:
  4. Temporary tacked straw shall conform to Section 13, Water Pollution Controls, of the State of California 2018 Standard Specifications and to these technical specifications
- G. Erosion Control (Hydroseed)
1. Erosion Control (Hydroseed) work shall include removing and disposing of weeds and applying erosion control materials including seed, fiber, commercial fertilizer, organic fertilizer, straw, and tackifier to erosion control (hydroseed) areas as shown on the Plans.
  2. Erosion Control (hydroseed) shall conform to the provisions in Section 21, Erosion Control, of the State of California 2018 Standard Specifications and these technical specifications.
  3. If notified by VTA that an area is ready to receive erosion control materials, start erosion control (hydroseed) work within 5 business days of the VTA notification to perform the Work.
  4. Seed:
  5. Seed shall conform to the provisions in Section 21, Erosion Control, of the State of California 2018 Standard Specifications and these technical specifications. Individual seed species shall be measured and mixed in the presence of VTA.
  6. Seed shall have been tested for purity and germination not more than one year prior to application of seed or said seed shall be retested at Contractor's expense.
  7. Results from testing or retesting seed for purity and germination shall be furnished to VTA prior to applying seed. Non-Legume Seed. Non-legume seed shall consist of the following:





*Project Name*  
*Contract C#XXXXX*

| <b>Non-Legume Seed</b>                       |                                 |                                      |  |
|--|---------------------------------|--------------------------------------|--|
| <b>Botanical Name (Common Name)</b>          | <b>Percent (Minimum) Purity</b> | <b>Percent (Minimum) Germination</b> | <b>lbs. per acre (Slope measurement)</b> |
| Festuca Idahoensis (Idaho Fescue)            | 95                              | 85                                   | 11.0                                     |
| Eschscholzia Californicum (California Poppy) | 95                              | 85                                   | 12.0                                     |
| Nassella Lipida (Foothill Needlegrass)       | 95                              | 85                                   | 6.5                                      |
| Lotus Scoparius (Deerweed)                   | 95                              | 85                                   | 2.0                                      |
| Nassella Pulchra (Purple Needlegrass)        | 95                              | 85                                   | 1.0                                      |
|  |                                 | <b>Total</b>                         | <b>32.5</b>                              |

8. A sample of approximately 1 oz of non-legume seed may be taken from each seed container by VTA.
- H. Temporary Drainage Inlet Protection:
1. Temporary drainage inlet protection will be installed, maintained, and later removed as shown on The Plans, as shown on the WPCP, as specified in these technical specifications, and as directed by VTA. Refer to the SE-10 cut sheet in the CASQA handbook for details. Temporary drainage inlet protection will be installed at each drainage system box location where runoff may enter the storm water system.
  2. Contractor will use temporary drainage inlet protection as one of the various measures to prevent water pollution.
  3. Temporary Gravel Filled Bag Dikes:
  4. Temporary gravel filled bag dikes consisting of gravel bags placed in multiple layers will be installed as shown on The Plans.
  5. Gravel filled bag dikes installed as part of temporary drainage inlet protection will be maintained to provide for adequate sediment holding capacity. Sediment deposits will be removed when the deposit reaches one-half of the temporary dike height. Removed sediment will be deposited within the project in such a way that it is not subject to erosion by wind or water, or as directed by VTA.
  6. Sediment Filter Bags:
  7. Sediment bags will be installed by removing the drainage inlet grates, placing the sediment bag in the opening, and replacing the grate to secure the sediment bag in place.
  8. Sediment bags installed as part of temporary drainage inlet protection will be emptied when the restraint cords are no longer visible. The sediment bag will be emptied of material and rinsed before replacement in the catch basin or drop inlet.



*Project Name*  
*Contract C#XXXXX*

9. The storage capacity of the sump area around each drain inlet will be maintained to provide for maximum capacity and as directed by VTA.
10. When no longer required for the purpose, as determined by VTA, temporary drainage inlet protection facilities will be removed. Removed facilities will become the property of Contractor and will be removed from the site of the Work
- I. Temporary Perimeter Protection:
  1. Sediment control will be achieved by well-planned and scheduled excavation, backfill, and paving and grinding operations and implementation of BMPs.
  2. Temporary Perimeter Protection will be provided as a sediment control device at the perimeter of construction staging areas and as needed for other work areas.
  3. Fiber Roll:
  4. The contract price paid per linear foot for Temporary Fiber Roll must include furnishing all labor materials, tools, equipment, and incidentals and for doing all the work involved in installing, maintaining, removing and disposal of temporary fiber rolls as shown on the Plans and shall conform to the provisions in Section 21, Erosion Control, of the State of California 2018 Standard Specifications and as specified in these technical specifications or as directed by VTA. Refer to the SC-5 cut sheet in the CASQA or Caltrans BMP handbook. They are to be placed at the top of the slope, face of the slope, and at grade breaks, per the following spacing (measured perpendicular to the slope):

| Critical Slope/Sheet Flow Length Combinations |                                 |
|---|---------------------------------|
| Slope Percentage                              | Sheet Flow Length Not to Exceed |
| 0 – 25  | 20 ft                           |
| 25 – 50                                       | 15 ft                           |
| Over 50                                       | 10 ft                           |

5. Fiber Rolls shall be installed approximately parallel to the slope contour across the centerline of ditch or drainage line and secured as shown on the Plans. Fiber rolls shall be installed before application of other erosion control materials.
6. Fiber rolls shall be installed to a depth of 2 in to 4 in, and at a sufficient width to hold the fiber rolls. The furrow shall be cleared of obstructions including rocks, clods, mulch, and debris greater than 1 in in diameter before installation. Fiber rolls shall be installed in the furrow and secured as shown on Plans. Excess soil from excavation of the furrow shall be disposed of uphill of the installed fiber rolls. Stakes shall be installed 24 in apart along the total length of the rolls, and 12 in from the end of each individual roll. Stakes shall be driven flush or a maximum of 2 in above the roll.
7. Fiber Rolls should be left in place until the upgradient area is permanently stabilized. Remove Fiber Roll when upgradient areas are stabilized. Fill and compact post holes and anchor trench, remove sediment accumulation, grade fence alignment to blend with adjacent ground, and stabilize disturbed area. Refer to the SC-5 cut sheet in the CASQA or Caltrans handbook.
8. No plastic mesh (monofilament wrapped) Fiber Roll is permitted on BMPs for VTA projects; specify fully biodegradable, not photodegradable, materials will be used.



*Project Name*  
*Contract C#XXXXX*

- 
9. Silt Fence
  10. Silt Fence must be prefabricated and conform to the provisions in Section 96-1.02E, Silt Fence Fabric, of the Caltrans Standard Specifications and these technical specifications.
  11. Silt fence fabric must be a prefabricated silt fence of woven polypropylene with or without an integral reinforcement layer of the same material and must have a minimum width of 36 in and a minimum tensile strength of 440 N, conforming to ASTM D4632.
  12. A trench should be excavated approximately 6 in. wide and 6 in. deep along the line of the proposed silt fence (trenches should not be excavated wider or deeper than necessary for proper silt fence installation).
  13. Bottom of the silt fence should be keyed-in a minimum of 12 in. Posts should be spaced a maximum of 6 ft apart and driven securely into the ground a minimum of 18 in. or 12 in. below the bottom of the trench.
  14. When standard strength geotextile is used, a plastic or wire mesh support fence should be fastened securely to the upslope side of posts using heavy-duty wire staples at least 1 in. long. The mesh should extend into the trench.
  15. Woven geotextile should be purchased in a long roll, then cut to the length of the barrier. When joints are necessary, geotextile should be spliced together only at a support post, with a minimum 6 in. overlap and both ends securely fastened to the post.
  16. The trench should be backfilled with native material and compacted.
  17. Construct the length of each reach so that the change in base elevation along the reach does not exceed 1/3 the height of the barrier; in no case should the reach exceed 500 ft.
  18. Repair undercut silt fences.
  19. Repair or replace split, torn, slumping, or weathered fabric. The lifespan of silt fence fabric is generally 5 to 8 months.
  20. Silt fences that are damaged and become unsuitable for the intended purpose should be removed from the site of work, disposed, and replaced with new silt fence barriers.
  21. Sediment that accumulates in the BMP should be periodically removed in order to maintain BMP effectiveness. Sediment should be removed when the sediment accumulation reaches 1/3 of the barrier height.
  22. Silt fences should be left in place until the upgradient area is permanently stabilized. Until then, the silt fence should be inspected and maintained regularly. Remove silt fence when upgradient areas are stabilized. Fill and compact post holes and anchor trench, remove sediment accumulation, grade fence alignment to blend with adjacent ground, and stabilize disturbed area. Refer to the SE-1 cut sheet in the CASQA handbook or SC-1 Caltrans handbook.
  23. Hard Surface Guard
  24. Use Hard Surface Guard™ from ERTEC®. Perimeter Sediment Control System or equivalent product for hard surfaces (such as asphalt or concrete). The intended function of the Sediment



*Project Name*  
*Contract C#XXXXX*

Control System for Hard Surfaces is to minimize the flow of sediment into storm drain systems.

25. Perform maintenance as required. Inspect following rainfall events and at least daily during prolonged rainfall. Maintain to provide an adequate sediment holding capacity. Sediment will be removed as needed. Removed sediment will be disposed-of outside the project or in conformance with requirements. Damage to Perimeter Sediment Control System for hard surfaces resulting from the Contractor's vehicles, equipment, or operations will be repaired at the contractor's expense. Split or torn segments will be repaired with zip-ties, 16-gauge galvanized wire or replaced. Deformed segments will be reshaped. Locations where evidence of runoff has occurred beneath the Perimeter Sediment Control System for hard surfaces will be corrected. Segments needing repair will be repaired or replaced within 24 hours of identifying the deficiency.
26. Furnish "L" shaped sediment control device with a height of 6 inches as per manufacturers recommendations. Each segment will be 7 feet long and have minimum vertical freeboard of at least 6 inches with a 4-inch hinged horizontal flap at the base, to be secured in place with pneumatically applied nails, pea gravel, gravel bags or bonding agent. Apparent Opening Size. Furnish Perimeter Sediment Control System for hard surfaces containing a filter fabric such that the Apparent Opening Size is between 200 and 250 microns. The Percentage Open Area (POA) should be greater than 20%. Structure. Furnish sediment control device manufactured from non-biodegradable materials which is UV Stable for at least 4 years. The system will comprise semi-rigid, overlapping layers of thermally extruded, apertured polymeric high-density polyethylene (HDPE) sheets, and one or more integrated filter sheets. The system will be durable, such that it can be returned to original shape when deformed on the job site. The Perimeter Sediment Control System for hard surfaces will have an integrated filter fabric. The system will comprise a gasket attached to the bottom to prevent underflow. The system will also conform to the following:

| Specification  | Requirements |
|--|--------------|
| Height (freeboard), inches, min. – sheet flow – typically 99% of perimeter   | 6 or 10      |
| Mass per Unit Weight, (pounds/foot) (maximum) (6" / 10")   | 0.39 / 0.50  |
| Tensile Yield ASTM D-638 (lb/in <sup>2</sup> )   | 1800 - 2800  |
| Ultimate Tensile Strength: ASTM D-638 (lb/in <sup>2</sup> )  | 2000 - 2800  |
| Filter Percentage Open Area (POA) (COE 22125-86) (min %)   | 20           |
| Filter Average Opening Size (AOS) (ASTM D 4751) microns  | 250          |
| Ultraviolet stability (outer jacket & filter), percent tensile strength retained after 500 hours, min. ASTM Designation: D 4355 (xenon-arc lamp and water spray weathering method) | 90           |
| Gasket Weight (minimum ounces per square yard)   | 14.5         |
| Life in application (years - minimum)  | 4            |
| * or appropriate test method for specific polymer  |              |

27. A copy of the manufacturer's product sheet together with instructions for installation will be furnished to VTA 5 days before installation.
28. Temporary Perimeter Protection for hard surfaces can be installed in the following alternative ways: On asphalt: Install nails flush with netting so that gasket is in good contact with surface. Install 4 to 5 nails per each seven-foot segment. Use HILTI X-ZF 1½ inch fasteners with 23-millimeter pre-mounted steel washer (X-ZF 32 P8 S23) or equivalent with automatic powder-actuated hand tool.
29. Concrete: Install anchors flush with netting so that gasket is in good contact with surface. Install 4 to 5



*Project Name*  
*Contract C#XXXXX*

---

anchors per each seven-foot segment. Use Red Head Redi-Drive or Hammer Set “¼ x 1-1/4” anchors or equivalent. Asphalt or Concrete: Install bonding agent between gasket and surface. Use PaverBond, Liquid Nails, or other equivalent. Anchor with gravel bags or other weights until set.

J. Temporary Construction Entrance

1. Temporary construction entrance shall be constructed, maintained, and later removed as shown on Plans, as specified in these technical specifications, and as directed by VTA. The work shall consist of furnishing all materials and installing construction entrances at points of construction ingress and egress for the purpose of reducing track out of sediments and other pollutants onto paved roadways.
2. Temporary construction entrances shall be removed immediately following completion of work at the above locations and as directed by VTA.
3. The fabric for construction entrances shall be handled and placed in accordance with the manufacturer's recommendations. A 2 ft minimum overlap will be required at adjoining pieces. Care shall be taken to install the fabric taut and aligned with as little wrinkling as possible. Should the fabric be damaged during placing, the torn or punctured sections shall be repaired as required and shall meet overlapping requirements. Damage incurred due to Contractor's vehicles, equipment or operations shall be repaired by Contractor at his expense.
4. A 3.3 ft skirt of fabric shall extend beyond the cross-sectional limits of the rock bed as shown in the CASQA BMP Handbook or as directed by VTA.
5. The temporary construction entrance shall be graded to prevent runoff from leaving the construction site and flowing onto paved roadways.
6. The temporary construction entrance shall be a minimum of 50 ft in length.
7. The rock bed shall be spread to a minimum depth of 6 in. Additional rock shall be added as directed by VTA to maintain the rock bed

K. Street Sweeping:

1. Perform street sweeping daily, prior to rain, and as needed where sediment is tracked from the active work areas onto paved areas in accordance with the CASQA BMP Handbook, during hauling operations, and to keep all paved surfaces free of sediment and erodible materials. Sweepers will be self-loading, motorized, and will have spray nozzles and vacuum apparatus. Dry brooming is not permitted.

L. Temporary Concrete Washout

1. Concrete washouts must be constructed per an approved engineering detail (reference WM-8 cut sheet in California Department of Transportation (Caltrans) handbook, or equivalent standard details), no recreational kiddie pools will be used.
2. The washout must be placed properly to avoid leaks and prevent overflow.
3. Ensure that the concrete residue solidifies prior to moving or dispose of concrete waste within a timely fashion after concrete residue solidifies.



*Project Name*  
*Contract C#XXXXX*

---

4. Cover all washouts prior to forecast rain.

**4.01 QUALITY ASSURANCE**

2. Refer to **SC-33, Contractor's Quality Management Plan (CQMP)** for Contractor's responsibilities for Quality Assurance

**5.01 RESTORATION**

1. Holes, depressions, sumps, or any other ground disturbance caused by the removal of the drainage inlet protection facilities, check dams, will be backfilled and repaired in accordance with the provisions in the first paragraph of **Section 15-1.03A, "General," of the State of California 2018 Standard Specifications.**

END OF SECTION 01 57 23



**ATTACHMENT N:**  
ESCAPE SPECIFICATION



**ATTACHMENT N:**  
ESCAPE SPECIFICATION





Project Name  
CONTRACT Pxxxx

---

**SECTION 01 57 23**

**TEMPORARY STORM WATER POLLUTION**

**EROSION AND SEDIMENT CONTROL ACTION PLAN ELEMENT (ESCAPE)**

**PART 1 GENERAL**

**1.05 SECTION INCLUDES**

- A. For projects that disturb less than 1 acre, an ESCAPE is required on VTA projects. An ESCAPE is similar in nature to a SWPPP and require BMPs to be used that are site-specific. Attachment M of the VTA Stormwater Design Criteria Manual includes VTA Appendix G of the VTA contract specifications and contains the ESCAPE template for contractors to complete. This manual assists designers with the selection of compliant BMPs.
- B. This Section includes requirements for water pollution control water pollution control during construction including Best Management Practices (BMPs), maintenance, erosion, sediment control, dust control, and waste management.
- C. Water pollution control maintenance work and Erosion Sediment (ESCAPE) must be considered as integral functional practices to implement water pollution control.
- D. Water pollution control maintenance work and the ESCAPE are integral functional practices that Contractor must implement to control water pollution.
- E. Failure to fully comply with the requirements of this spec will subject Contractor to all fines, damages, and delays incurred due to failure to implement the ESCAPE.

**1.06 RELATED SECTIONS**

Appendix G Environmental Coordination and Cooperation

Special Conditions, General Conditions, and these Technical Specifications.

SECTION 6 SPECIAL CONDITIONS

SECTION 7 GENERAL CONDITIONS

01 35 29 HAZARDOUS MATERIALS ACCIDENT PREVENTION

01 35 70 ENVIRONMENTAL REQUIREMENTS

01 57 00 TEMPORARY CONTROLS

01 74 14 CLEANING

01 74 15 DUST CONTROL

01 74 21 WASTE MANAGEMENT

01 74 25 CONTAMINANT MANAGEMENT

01 75 00 PRESERVATION AND RESTORATION

02 41 00 DEMOLITION

02 41 10 TREE PROTECTION AND REMOVAL

03 05 15 PORTLAND CEMENT CONCRETE

22 14 01 STORM DRAINAGE

31 00 00 EARTHWORK

31 11 00 CLEARING AND GRUBBING

31 23 19 DEWATERING

31 23 43 STRUCTURE EXCAVATION AND BACKFILL

---

RELEASE:  
Issued: XX/XX/XXXX

01 57 23-1  
Page 1 of 15

VTA FACILITIES STANDARDS  
STANDARD SPECIFICATIONS



**Project Name**  
**CONTRACT Pxxxx**

- 31 32 00 HYDROSEEDING
- 31 35 00 SLOPE PROTECTION
- 32 90 00 PLANTING
- 33 40 00 STORM DRAINAGE UTILITIES
- 33 41 13 STORM DRAINAGE
- 33 46 00 OUTFALL PROTECTION

**1.07 REGULATORY REQUIREMENTS**

A. Include the permits that are relevant, depending on the project’s disturbance acreage and the right-of-way; Pursuant to the applicable laws and requirements for the work, including but not limited to the:

1. The National Pollutant Discharge Elimination System (NPDES) permits General Permit No. CAS000002 for Storm Water Discharges Associated with Construction and Land Disturbance Activities adopted by the State Water Resources Control Board on September 2, 2009 as Order No. 2009-0009-DWQ, This section is subject to changes proposed by the revised Construction General Permit (DRAFT ORDER 20XX-XXXX-DWQ NPDES NO. CAS000002). Designer to include when the new CGP is issued, and update the above reference.
2. The Municipal Regional Permit No. CAS612008 for Municipal Separate Storm Water Discharges Associated with jurisdictions and entities permitted under the San Francisco Bay Municipal Regional Stormwater Permit adopted by the State Water Resources Control Board on November 19, 2015 as Order No. R2-2015-0049 , and Phase II MS4 Permit No. CAS000004 for Storm Water Discharges Associated with Small Municipal Separate Storm Water Discharges adopted by the State Water Resources Control Board on February 5, 2013 as Order No. 2013-0001-DWQ.

B. VTA’s Design Criteria Manual for Landscaping and Stormwater

**1.08 MEASUREMENT AND PAYMENT**

A. Full compensation for conforming to the requirements of this section will be paid for as described in the various associated bid items in the Schedule of Quantities and Prices (SQP).

B. Prepare ESCAPE

The contract lump sum price paid per each for ESCAPE Preparation includes full compensation for all Work necessary for developing, preparing, obtaining approval of, revising, and amending the ESCAPE. For the pay item “Prepare ESCAPE”, Contractor will receive 50% of the pay item for submittal of the ESCAPE and the remaining 50% when the ESCAPE is approved, no more corrections are required, and the corrected ESCAPE has been submitted. Refer to Section 7 for details on special withholding.

C. Amend ESCAPE

For the pay item “Amend ECAPE”, contractor will receive 0% of the pay item for submittal of the ESCAPE Amendment or if VTA identifies “Amend and Resubmit”, 50% of the pay item if VTA identifies “Make Correction Noted”, and 100% of the pay item if VTA identifies “No Exception Taken”. For any amendment not transmitted to VTA within 14 days of request, VTA



**Project Name**  
**CONTRACT Pxxxx**

---

will deduct from the pay item. Refer to Section 7 for details on special withholding.

D. Inspections

Inspections will be paid per each and will be **Weekly/bi-weekly/Monthly** for the duration of the project. Contractor will receive 100% of the pay item for **Weekly/bi-weekly/Monthly** “ESCAPE Inspections” upon completion of the submitted **Weekly/bi-weekly/Monthly** inspection to VTA. ESCAPE Inspections will be captured in the CloudCompli (www.cloudcompli.com) inspection software within 24-hours of performing the inspection. Contractor must purchase annual licenses from CloudCompli as necessary to meet this requirement. VTA will deduct from the pay item for any inspections not performed per the template or for any reports not submitted within a pay period. Refer to VTA Section 7 for details on special withholding.

**Designer to estimate all of the below quantities as outlined in the VTA Design Criteria Manual for Stormwater, Planting, and Irrigation (VTA DCM). Customize the Measurement and Payment section to only include the applicable BMPs and items.**

E. Construction Site Management

The contract lump sum price paid for Construction Site Management must include furnishing all labor, materials, tools, equipment, and incidentals, and for doing all the work involved in construction site management including but not limited to run-on run-off controls, rock bags, spill prevention and control, material management, waste management, non-stormwater management, and dewatering activities, as specified in these technical specifications, and as directed by VTA.

F. Temporary Cover

The contract price paid per lump sum for Temporary Cover must include furnishing all labor materials, tools, equipment, and incidentals and for doing all the work involved in installing, maintaining, removing and disposal of Temporary Covers as shown on the Plans, as specified in these technical specifications, and as directed by VTA.

G. Erosion Control Blanket

Erosion Control Blanket will be measured by the square foot. The area will be calculated on the basis of actual or computed slope measurements. The contract price paid per square foot includes full compensation for furnishing all labor, materials, tools, equipment, and incidentals, and for doing all the work involved in installing Erosion Control Blanket, complete in place **and removal of Temporary Erosion Control Blanket**, as shown on the Plans, as specified in these technical specifications, and as directed by VTA.

H. Temporary Hydraulic Mulch

The contract price paid per square yard for Temporary Hydraulic Mulch must include furnishing all labor materials, tools, equipment, and incidentals and for doing all the work involved in installing, maintaining, removing and disposal of temporary hydraulic mulch as shown on the Plans, specified in these technical specifications, and as directed by VTA.

I. Erosion Control (Hydroseed)



**Project Name**  
**CONTRACT Pxxxx**

---

Erosion control (hydroseed) will be measured by the square foot. The area will be calculated on the basis of actual or computed slope measurements. The contract price paid per square foot for erosion control (hydroseed) includes full compensation for furnishing all labor, materials, tools, equipment, and incidentals, and for doing all the Work involved in erosion control (hydroseed) complete in place, as shown on the Plans, as specified in these technical specifications, and as directed by VTA

J. Temporary Drainage Inlet Protection.

The contract price paid per unit for Temporary Drainage Inlet Protection must include furnishing all labor materials, tools, equipment, and incidentals and for doing all the work involved in installing, maintain, removing and disposal of temporary drainage inlet protection as shown on the Plans, specified in these technical specifications, and as directed by VTA. Deduct from the pay item for any DI protection that is not placed, replaced, or not maintained in a timely fashion (i.e., within 14 days of a VTA request).

K. Temporary Perimeter Protection

The contract price paid per linear feet for Temporary Perimeter Protection measured along the centerline of the installed strip for hard surfaces include full compensation for furnishing all labor, materials, tools, equipment, and incidentals, and for doing all the work involved in installing the Temporary Perimeter Protection, complete in place, including maintenance, and in these special provisions, and as directed by VTA. Where Temporary Perimeter Protection segments are joined and overlapped, the overlap will be measured as a single installed strip.

L. Temporary Construction Entrance

Temporary construction entrance will be paid per each. The price for Temporary Construction Entrance includes full compensation for furnishing all labor, materials, tools, equipment, and incidentals, and for doing all the Work involved in constructing temporary construction entrance, complete in place, including removal of temporary construction entrance, as shown on the Plans, these technical specifications, and as directed by the VTA.

No additional compensation will be made if the temporary construction entrance is relocated during the course of construction.

M. Street Sweeping

The contract lump sum price for Street Sweeping must include furnishing all labor materials, tools, equipment (Sweepers shall be self-loading, motorized, and shall have spray nozzles and vacuum apparatus, dry brooming is not permitted.), and incidentals and for doing all the work involved in street sweeping as specified in these technical specifications, and as directed by VTA.

N. Temporary Concrete Washout

The contract lump sum for Temporary Concrete Washout must include furnishing all labor materials, tools, equipment, and incidentals and for doing all the work involved in installing, maintaining, removing and disposal of temporary concrete washout as shown on the Plans, specified in these technical specifications, and as directed by VTA. One washout/300 yards of concrete will be required at a minimum.



Project Name  
CONTRACT Pxxxx

- 
- O. All other items of temporary controls will not be measured for payment but will be considered incidental to the Work of this Contract

**1.09 REFERENCE STANDARDS**

VTA Design Criteria Manual for Stormwater , Landscaping, and Irrigation (**most recent version**)

California Environmental Protection Agency, State Water Resource Control Board  
<http://www.swrcb.ca.gov/>

California Storm water Quality Association (CASQA) Stormwater Best Management Practice Online Handbook: Construction (the Construction BMP Handbook is available at CASQA.org)

California Regional Water Quality Control Board (RWQCB) – Region 2, Order No. R2-2015-0049, NPDES Permit No. CAS612008, San Francisco Bay Region Municipal Regional Storm water NPDES Permit, November 19, 2015 (hereafter Municipal Regional Permit or MRP)

State Water Resources Control Board (SWRCB) – Order No. 2013-001-DWO, NPDES Permit No. CAS000004, Waste Discharge Requirements for Storm Water Discharges form Small Municipal Separate Storm Sewer System (MS4s) February 5, 2013 (hereafter Small Phase 2, Permit).

Santa Clara Valley Urban Runoff Pollution Prevention Program (SCVURPPP), C.3 Storm water Handbook, (**latest version, and addendum.**)

**1.10 SUBMITALS**

- A. ESCAPE Preparation:
  - 1. Contractor will prepare the ESCAPE using the VTA template format included in this specification in accordance with the VTA Stormwater Design Criteria Manual. VTA will oversee compliance with these requirements. **VTA prefers that the contractor use a Qualified SWPPP Developer (QSD), a Certified Professional in Erosion and Sediment Control (CPESC) registered through Enviro Cert International, Inc., or a Certified Professional in Storm Water Quality (CPSWQ) registered through Enviro Cert International, Inc. to prepare and amend the ESCAPE.**
  - 2. The Contractor must submit for review and approval an ESCAPE with WPCD showing the project specific locations to implementation the proposed BMPs and if site conditions change. **Refer to the ESCAPE template attached to this specification section and update the ESCAPE template accordingly specific to the contract work means and methods.**
  - 3. All revisions will be submitted to VTA for approval prior to incorporation.
  - 4. The Contractor will submit to VTA a list of the Contractor’s materials and sources. The list will be submitted in sufficient time to implement the proper level of controls before the construction work commences. No plastic mesh (monofilament wrapped) is permitted in rolled products on VTA projects (i.e., fiber rolls and erosion control blankets must be made from fully biodegradable, not photodegradable, materials)



**Project Name**  
**CONTRACT Pxxxx**

- 
5. Submit the following submittals for the stormwater treatment BMP: include the details, calculations, manufactures recommendation as part of an Operations and Maintenance Plan for the post construction BMP selected to treat the impervious area constructed by the project.
  6. Contractor will update the WPCD for specific means and methods drawings to show the site conditions:
    - Contractor will update the WPCD to show the site conditions, drainage, and water pollution control components. At a minimum, the WPCD will include:
      - All exposed graded surfaces, finished and unfinished construction slopes, stockpiles, haul roads and storage areas, top and toe of slope lines and drainage arrows will be graphically shown.
      - Drainage patterns within each watershed area (shown by slope arrows) and the drainage system or containment area where runoff will be conveyed for removal or storage. Drainage swales, temporary culverts, active and inactive drainage inlets, gutters, and dikes will be clearly shown at a minimum as well as where offsite water enters or exits the site, along with uniquely named or numbered sampling point locations.
      - Locations where offsite run-on to the Work area and where runoff leaves the work area.
      - Contractor will identify, as minimum, storage facilities, concrete washout areas and proposed stockpile locations.
      - Water pollution control BMPs will also be shown and may consist of providing drainage inlet protection around or temporarily capping selected drainage systems within areas of active construction. Contractor will monitor the weather forecast to anticipate if inclement weather is approaching. Uncapping drainage inlets and providing measures to trap sediment will be installed prior to the storm. Contractor will maintain BMPs as required during and after the storm event.
- B. Designer to confirm whether dewatering will be addressed in this section and not in a separate dewatering spec. Before dewatering, the Contractor will submit a dewatering and discharge work plan. The dewatering and discharge work plan will include:**
1. Title sheet and table of contents.
  2. Description of dewatering and discharge activities detailing locations, quantity of water, equipment, and discharge point.
  3. Estimated schedule for dewatering and discharge start and end dates of intermittent and continuous activities.
  4. Discharge alternatives, such as dust control or percolation.
  5. Visual monitoring procedures with inspection log.
  6. Copy of written approval to discharge into a sanitary sewer system at least 7 days before starting discharge activities.
- C. The Contractor will submit the following:**



Project Name  
CONTRACT Pxxxx

- 
1. Material Safety Data Sheet at least 7 days before material is used or stored.

**PART 2 PRODUCTS (NOT USED)**

**PART 3 EXECUTION**

A. Prepare Erosion and Sediment Control Action Plan Element (ESCAPE):

1. This section covers Work necessary for stabilization of soil to prevent erosion during construction and land disturbing activities in compliance with VTA's MS4 permit. VTA reserves right to modify use, location, and quantities of soil erosion and sediment control measures based on activities of Contractor.
2. Conformance with the requirements of this Section in no way relieves Contractor from its responsibilities, as provided in GC-45, Protection and Restoration of Property and SC-1, Indemnification. Contractor will be fully responsible for all costs and liabilities associated with storm water pollution and temporary erosion control Work for the project.
3. Contractor will monitor the weather forecast on a daily basis. If rain is predicted within 48 hours, construction scheduling will be modified, as required, to implement BMPs prior to the onset of the rains

B. Amend ESCAPE

1. All ESCAPE amendments will be submitted to VTA for approval prior to incorporation. During the course of construction, unanticipated changes may occur, such as schedule changes, phasing changes, and staging area modifications. The ESCAPE must be revised to reflect these changes and must also be revised when a new BMP is needed. All revisions will be submitted to VTA for approval prior to incorporation.

C. Inspections

1. All SWPPP Inspections will be captured in the CloudCompli (www.cloudcompli.com) inspection software within 24-hours of performing the inspection, and inspection documentation will be formally submitted to VTA Weekly/bi-weekly/Monthly. Contractor will purchase CloudCompli licenses at a cost of \$1,200 per user per year from CloudCompli (Designer to confirm cost with VTA compliance Officer) as necessary to meet this requirement, so they can be given a log-on identification and password to access the VTA's CloudCompli project dashboard.
2. All inspections, daily visual monitoring of track-out and trash areas, and BMP inspections before and after a storm event, are required to be conducted in CloudCompli.
3. All deficiencies must be corrected within 72-hours.

Designer to customize all of the below BMPs as outlined in the VTA Design Criteria Manual for Stormwater, Planting, and Irrigation (VTA DCM). Customize this section to only include the applicable BMPs and items.

D. Construction Site Management:



**Project Name**  
**CONTRACT Pxxxx**

- 
4. Keep materials or waste storage areas clean, well-organized, and equipped with enough cleanup supplies for the material being stored.
  5. Implement spill and leak prevention procedures for chemicals and hazardous substances stored on the job site. All associated cleanup costs and related liability for spilled or leaked chemicals or hazardous substances at the job site are the responsibility of the Contractor.
  6. Report minor, semi-significant, and significant or hazardous spills to the VTA immediately.
  7. As soon as it is safe, contain and clean up spills of petroleum materials and sanitary and septic waste substances listed under 40 CFR, Parts 110, 117, and 302.
  8. Conduct construction operations in a manner that will minimize pollution of the environment surrounding the area of the Work by all practicable means and methods. Apply specific controls as specified in the Contract Specifications and as follows:
    - a. Waste Materials: No waste or eroded materials will be allowed to enter natural or man-made water or sewage removal systems. Eroded materials from excavations, borrow areas, or stockpiled fill will be contained within the Work area. The Contractor will develop methods for control of erosion.
    - b. Burying: No burying of waste materials and debris will be permitted.
  9. Provide for and maintain the flow of all sewers, drains, building or inlet connections, and all water courses which may be encountered during progress of the Work. Do not allow the contents of any sewer, drain, or building or inlet connection to flow into trenches. Immediately remove from proximity of the Work all offensive matter, using such precautions as are required by local authorities having jurisdiction.
  10. The Contractor will prevent erosion of excavated areas, embankments, stockpiled earth materials, and other erodible areas, and will provide control of runoff sediment from siltation and pollution of the drainage systems.
  11. Prevent erosion of excavated areas, embankments, stockpiled earth materials, and other erodible construction areas, and prevent pollution of drainage systems by diversion of storm runoff around construction activities or by trapping or retaining sediment delivered by storm runoff.
  12. Provide control of construction operations so that sediment or siltation will not be introduced into the drainage systems from storm runoff.
  13. If the earthwork/paving in any area has not progressed to a point where all or part of the facilities on the SWPPP for that area can be constructed, Contractor will construct such supplementary temporary erosion control facilities as are necessary to protect adjacent private and public property at all times.
  14. Water pollution control measures will be constructed and functioning to prevent water pollution from areas where portions of the Contract have been completed and no further earthwork/paving is planned.
  15. All egress from the site will be maintained in a dry condition, and any sediment tracked onto





**Project Name**  
**CONTRACT Pxxxx**

---

streets, sidewalks, or drives will be immediately removed, and the affected area will be cleaned. VTA may order such work at any time the conditions warrant.

16. All trucks coming to the jobsite or leaving the jobsite with materials or loose debris will be loaded in a manner that will prevent dropping of materials or debris on streets. Spillage resulting from hauling operations along or across any public traveled way will be removed immediately.
  17. Dust palliative will conform to the provisions in 01 57 00, Temporary Controls, of these technical specifications
- E. Temporary Cover
1. Protect stockpiled materials to prevent erosion and exposure of stormwater to pollutants.
- E. Erosion Control Blanket
1. Erosion Control Blanket shall conform to the provisions of Section 13, Water Pollution Control, and Section 21, Erosion Control, of the State of California 2018 Standard Specifications and to these technical specifications or as directed by VTA.
  2. Erosion Control Blanket shall be furnished and installed, as specified in the technical specifications, as shown on The Plans and at the locations designated by VTA
  3. Monofilament plastic mesh shall not be used.
  4. Temporary blanket shall be installed at locations to control erosion on critical areas of unfinished earthwork slopes. When no longer required for the purpose as determined by VTA, temporary blanket shall be abandoned or removed as directed by VTA.
- F. Temporary Hydraulic Mulch
1. **The designer to select Hydraulic Mulch or Bonded Fiber Matrix (BFM) based on project type and shall conform to the provisions in Section 21, Erosion Control, of the State of California 2018 Standard Specifications and these technical specifications**
- G. Erosion Control (Hydroseed)
1. Erosion Control (Hydroseed) work shall include removing and disposing of weeds and applying erosion control materials including seed, fiber, commercial fertilizer, organic fertilizer, straw, and tackifier to erosion control (hydroseed) areas as shown on the Plans.
  2. Erosion Control (hydroseed) shall conform to the provisions in Section 21, Erosion Control, of the State of California 2018 Standard Specifications and these technical specifications.
  3. If notified by VTA that an area is ready to receive erosion control materials, start erosion control (hydroseed) work within 5 business days of the VTA notification to perform the Work.
  4. Seed:
  5. Seed shall conform to the provisions in Section 21, Erosion Control, of the State of California 2018 Standard Specifications and these technical specifications. Individual seed species shall



**Project Name  
CONTRACT Pxxxx**

be measured and mixed in the presence of VTA.

6. Seed shall have been tested for purity and germination not more than one year prior to application of seed or said seed shall be retested at Contractor's expense.
7. Results from testing or retesting seed for purity and germination shall be furnished to VTA prior to applying seed. Non-Legume Seed. Non-legume seed shall consist of the following:

| <b>Non-Legume Seed</b>                       |                                 |                                      |  |
|--|---------------------------------|--------------------------------------|--|
| <b>Botanical Name (Common Name)</b>          | <b>Percent (Minimum) Purity</b> | <b>Percent (Minimum) Germination</b> | <b>lbs. per acre (Slope measurement)</b> |
| Festuca Idahoensis (Idaho Fescue)            | 95                              | 85                                   | 11.0                                     |
| Eschscholzia Californicum (California Poppy) | 95                              | 85                                   | 12.0                                     |
| Nassella Lipida (Foothill Needlegrass)       | 95                              | 85                                   | 6.5                                      |
| Lotus Scoparius (Deerweed)                   | 95                              | 85                                   | 2.0                                      |
| Nassella Pulchra (Purple Needlegrass)        | 95                              | 85                                   | 1.0                                      |
|  |                                 | <b>Total</b>                         | <b>32.5</b>                              |

8. A sample of approximately 1 oz of non-legume seed may be taken from each seed container by VTA.
- H. Temporary Drainage Inlet Protection:
1. Temporary drainage inlet protection will be installed, maintained, and later removed as shown on the WPCD, shall conform to the provisions in Section 13, Water Pollution Control, of the State of California 2018 Standard Specifications, and these technical specifications, and as directed by VTA.
  2. Contractor will use temporary drainage inlet protection as one of the various measures to prevent water pollution.
  3. Temporary Gravel Filled Bag Dikes:
  4. Temporary gravel filled bag dikes consisting of gravel bags placed in multiple layers will be installed as shown on The Plans.
  5. Gravel filled bag dikes installed as part of temporary drainage inlet protection will be maintained to provide for adequate sediment holding capacity. Sediment deposits will be removed when the deposit reaches one-half of the temporary dike height. Removed sediment will be deposited within the project in such a way that it is not subject to erosion by wind or water, or as directed by VTA.



**Project Name**  
**CONTRACT Pxxxx**

- 6. Sediment Filter Bags:
  - 7. Sediment bags will be installed by removing the drainage inlet grates, placing the sediment bag in the opening, and replacing the grate to secure the sediment bag in place.
  - 8. Sediment bags installed as part of temporary drainage inlet protection will be emptied when the restraint cords are no longer visible. The sediment bag will be emptied of material and rinsed before replacement in the catch basin or drop inlet.
  - 9. The storage capacity of the sump area around each drain inlet will be maintained to provide for maximum capacity and as directed by VTA.
  - 10. When no longer required for the purpose, as determined by VTA, temporary drainage inlet protection facilities will be removed. Removed facilities will become the property of Contractor and will be removed from the site of the Work
- I. Temporary Perimeter Protection:
  - 1. Sediment control will be achieved by well-planned and scheduled excavation, backfill, and paving and grinding operations and implementation of BMPs.
  - 2. Temporary Perimeter Protection will be provided as a sediment control device at the perimeter of construction staging areas and as needed for other work areas.
- 3. Fiber Roll:
  - 4. The contract price paid per linear foot for Temporary Fiber Roll must include furnishing all labor materials, tools, equipment, and incidentals and for doing all the work involved in installing, maintaining, removing and disposal of temporary fiber rolls as shown on the WPCDs shall conform to the provisions in Section 21, Erosion Control, of the State of California 2018 Standard Specifications, and as specified in these technical specifications or directed by VTA. They are to be placed at the top of the slope, face of the slope, and at grade breaks, per the following spacing (measured perpendicular to the slope):

| Critical Slope/Sheet Flow Length Combinations |                                 |
|---|---------------------------------|
| Slope Percentage                              | Sheet Flow Length Not to Exceed |
| 0 – 25  | 20 ft                           |
| 25 – 50                                       | 15 ft                           |
| Over 50                                       | 10 ft                           |

- 5. Fiber Rolls shall be installed approximately parallel to the slope contour across the centerline of ditch or drainage line and secured as shown on the Plans. Fiber rolls shall be installed before application of other erosion control materials.
- 6. Fiber rolls shall be installed to a depth of 2 in to 4 in, and at a sufficient width to hold the fiber rolls. The furrow shall be cleared of obstructions including rocks, clods, mulch, and debris greater than 1 in in diameter before installation. Fiber rolls shall be installed in the furrow and secured as shown on Plans. Excess soil from excavation of the furrow shall be disposed of uphill of the installed fiber rolls. Stakes shall be installed 24 in apart along the total length of the rolls, and 12 in from the end of each individual roll. Stakes shall be driven flush or a maximum of 2 in above the roll.



**Project Name**  
**CONTRACT Pxxxx**

7. Fiber Rolls should be left in place until the upgradient area is permanently stabilized. Remove Fiber Roll when upgradient areas are stabilized. Fill and compact post holes and anchor trench, remove sediment accumulation, grade fence alignment to blend with adjacent ground, and stabilize disturbed area. Refer to the SC-5 cut sheet in the CASQA or Caltrans handbook.
8. No plastic mesh (monofilament wrapped) Fiber Roll is permitted on BMPs for VTA projects; specify fully biodegradable, not photodegradable, materials will be used.
9. Silt Fence
10. Silt Fence must be prefabricated and conform to the provisions in Section 96, Geosynthetics, of the State of California 2018 Standard Specifications and these technical specifications.
11. Silt fence fabric must be a prefabricated silt fence of woven polypropylene with or without an integral reinforcement layer of the same material and must have a minimum width of 36 in and a minimum tensile strength of 440 N, conforming to ASTM D4632.
12. A trench should be excavated approximately 6 in. wide and 6 in. deep along the line of the proposed silt fence (trenches should not be excavated wider or deeper than necessary for proper silt fence installation).
13. Bottom of the silt fence should be keyed-in a minimum of 12 in. Posts should be spaced a maximum of 6 ft apart and driven securely into the ground a minimum of 18 in. or 12 in. below the bottom of the trench.
14. When standard strength geotextile is used, a plastic or wire mesh support fence should be fastened securely to the upslope side of posts using heavy-duty wire staples at least 1 in. long. The mesh should extend into the trench.
15. Woven geotextile should be purchased in a long roll, then cut to the length of the barrier. When joints are necessary, geotextile should be spliced together only at a support post, with a minimum 6 in. overlap and both ends securely fastened to the post.
16. The trench should be backfilled with native material and compacted.
17. Construct the length of each reach so that the change in base elevation along the reach does not exceed 1/3 the height of the barrier; in no case should the reach exceed 500 ft.
18. Repair undercut silt fences.
19. Repair or replace split, torn, slumping, or weathered fabric. The lifespan of silt fence fabric is generally 5 to 8 months.
20. Silt fences that are damaged and become unsuitable for the intended purpose should be removed from the site of work, disposed, and replaced with new silt fence barriers.
21. Sediment that accumulates in the BMP should be periodically removed in order to maintain BMP effectiveness. Sediment should be removed when the sediment accumulation reaches 1/3 of the barrier height.
22. Silt fences should be left in place until the upgradient area is permanently stabilized. Until then,



**Project Name**  
**CONTRACT Pxxxx**

the silt fence should be inspected and maintained regularly. Remove silt fence when upgradient areas are stabilized. Fill and compact post holes and anchor trench, remove sediment accumulation, grade fence alignment to blend with adjacent ground, and stabilize disturbed area. Refer to the SE-1 cut sheet in the CASQA handbook or SC-1 Caltrans handbook.

23. Hard Surface Guard
24. Use Hard Surface Guard™ from ERTEC®. Perimeter Sediment Control System or equivalent product for hard surfaces (such as asphalt or concrete). The intended function of the Sediment Control System for Hard Surfaces is to minimize the flow of sediment into storm drain systems.
25. Perform maintenance as required. Inspect following rainfall events and at least daily during prolonged rainfall. Maintain to provide an adequate sediment holding capacity. Sediment will be removed as needed. Removed sediment will be disposed-of outside the project or in conformance with requirements. Damage to Perimeter Sediment Control System for hard surfaces resulting from the Contractor's vehicles, equipment, or operations will be repaired at the contractor's expense. Split or torn segments will be repaired with zip-ties, 16-gauge galvanized wire or replaced. Deformed segments will be reshaped. Locations where evidence of runoff has occurred beneath the Perimeter Sediment Control System for hard surfaces will be corrected. Segments needing repair will be repaired or replaced within 24 hours of identifying the deficiency.
26. Furnish "L" shaped sediment control device with a height of 6 inches as per manufacturers recommendations. Each segment will be 7 feet long and have minimum vertical freeboard of at least 6 inches with a 4-inch hinged horizontal flap at the base, to be secured in place with pneumatically applied nails, pea gravel, gravel bags or bonding agent. Apparent Opening Size. Furnish Perimeter Sediment Control System for hard surfaces containing a filter fabric such that the Apparent Opening Size is between 200 and 250 microns. The Percentage Open Area (POA) should be greater than 20%. Structure. Furnish sediment control device manufactured from non- biodegradable materials which is UV Stable for at least 4 years. The system will comprise semi-rigid, overlapping layers of thermally extruded, apertured polymeric high-density polyethylene (HDPE) sheets, and one or more integrated filter sheets. The system will be durable, such that it can be returned to original shape when deformed on the job site. The Perimeter Sediment Control System for hard surfaces will have an integrated filter fabric. The system will comprise a gasket attached to the bottom to prevent underflow. The system will also conform to the following:

| Specification  | Requirements |
|--|--------------|
| Height (freeboard), inches, min. – sheet flow – typically 99% of perimeter   | 6 or 10      |
| Mass per Unit Weight, (pounds/foot) (maximum) (6" / 10")   | 0.39 / 0.50  |
| Tensile Yield ASTM D-638 (lb/in2)  | 1800 - 2800  |
| Ultimate Tensile Strength: ASTM D-638 (lb/in2)   | 2000 - 2800  |
| Filter Percentage Open Area (POA) (COE 22125-86) (min %)   | 20           |
| Filter Average Opening Size (AOS) (ASTM D 4751) microns  | 250          |
| Ultraviolet stability (outer jacket & filter), percent tensile strength retained after 500 hours, min. ASTM Designation: D 4355 (xenon-arc lamp and water spray weathering method) | 90           |
| Gasket Weight (minimum ounces per square yard)   | 14.5         |
| Life in application (years - minimum)  | 4            |
| * or appropriate test method for specific polymer  |              |



**Project Name**  
**CONTRACT Pxxxx**

- 
27. A copy of the manufacturer's product sheet together with instructions for installation will be furnished to VTA 5 days before installation.
  28. Temporary Perimeter Protection for hard surfaces can be installed in the following alternative ways: On asphalt: Install nails flush with netting so that gasket is in good contact with surface. Install 4 to 5 nails per each seven-foot segment. Use HILTI X-ZF 1½ inch fasteners with 23 millimeter pre-mounted steel washer (X-ZF 32 P8 S23) or equivalent with automatic powder-actuated hand tool.
  29. Concrete: Install anchors flush with netting so that gasket is in good contact with surface. Install 4 to 5 anchors per each seven-foot segment. Use Red Head Redi-Drive or Hammer Set "¼ x 1-1/4" anchors or equivalent. Asphalt or Concrete: Install bonding agent between gasket and surface. Use PaverBond, Liquid Nails, or other equivalent. Anchor with gravel bags or other weights until set.
- J. Temporary Construction Entrance
1. Temporary construction entrance shall be constructed, maintained, and later removed as shown on WPCD, as specified in these technical specifications, and as directed by VTA. The work shall consist of furnishing all materials and installing construction entrances at points of construction ingress and egress for the purpose of reducing track out of sediments and other pollutants onto paved roadways.
  2. Temporary construction entrances shall be removed immediately following completion of work at the above locations and as directed by VTA.
  3. The fabric for construction entrances shall be handled and placed in accordance with the manufacturer's recommendations. A 2 ft minimum overlap will be required at adjoining pieces. Care shall be taken to install the fabric taut and aligned with as little wrinkling as possible. Should the fabric be damaged during placing, the torn or punctured sections shall be repaired as required and shall meet overlapping requirements. Damage incurred due to Contractor's vehicles, equipment or operations shall be repaired by Contractor at his expense.
  4. A 3.3 ft skirt of fabric shall extend beyond the cross-sectional limits of the rock bed as shown in the CASQA BMP Handbook or as directed by VTA.
  5. The temporary construction entrance shall be graded to prevent runoff from leaving the construction site and flowing onto paved roadways.
  6. The temporary construction entrance shall be a minimum of 50 ft in length.
  7. The rock bed shall be spread to a minimum depth of 6 in. Additional rock shall be added as directed by VTA to maintain the rock bed
- K. Street Sweeping:
1. Perform street sweeping daily, prior to rain, and as needed where sediment is tracked from the active work areas onto paved areas in accordance with the CASQA BMP Handbook, during hauling operations, and to keep all paved surfaces free of sediment and erodible materials. Sweepers will be self-loading, motorized, and will have spray nozzles and vacuum apparatus. Dry brooming is not permitted.



**Project Name**  
**CONTRACT Pxxxx**

- 
- L. Temporary Concrete Washout
    - 1. Concrete washouts must be constructed per an approved engineering detail (reference WM-8 cut sheet in California Department of Transportation (Caltrans) handbook, or equivalent standard details), no recreational kiddie pools will be used.
    - 2. The washout must be placed properly to avoid leaks and prevent overflow.
    - 3. Ensure that the concrete residue solidifies prior to moving or dispose of concrete waste within a timely fashion after concrete residue solidifies.
    - 4. Cover all washouts prior to forecast rain.

**4.01 QUALITY ASSURANCE**

- A. Refer to **SC-33, Contractor’s Quality Management Plan (CQMP)** for Contractor’s responsibilities for Quality Assurance
- B. Regulatory Requirements: Contractor to comply with provisions of the MS4 permit requirements.

**5.01 RESTORATION**

- A. Holes, depressions, sumps, or any other ground disturbance caused by the removal of the facilities will be backfilled and repaired in accordance with the provisions in the first paragraph of Section 15-1.03A, “General,” of the State of California 2018 Standard Specifications.

**END OF SECTION 01 57 23**

**ATTACHMENTS FOLLOW: ESCAPE Template**



**ATTACHMENT N:**  
N2: ESCAPE TEMPLATE





**Erosion and Sediment Control Action Plan Element  
(ESCAPE)**

for

**CONTRACT NAME  
CONTRACT Cxxxxxx**

Prepared for

Remi Awosanya - Contracts Compliance Manager  
The Santa Clara Valley Transportation Authority (VTA)  
3331 North First Street, Bldg. B  
San Jose, CA 95134



Submitted by

Project Address

Start Date: \_\_\_\_\_

End Date: \_\_\_\_\_

These documents are available for review by any interested party during the normal working hours at:  
[LOCATION]

[ADDRESS]



**1. PROJECT INFORMATION**

| <b>TABLE 1. PROJECT DETAILS</b> |  |
|---------------------------------|--|
| TYPE OF PROJECT                 | [LANDSCAPING, CLEAR AND GRUB, FENCING, SIGNAGE, etc.,] |
| CONSTRUCTION LIMITS:            | [FROM_]  |
| DURATION:                       | [MONTH, YEAR]  |
| START DATE:                     | [MONTH, DAY, YEAR]                                     |
| END DATE:                       | [MONTH, DAY, YEAR]                                     |
| <b>OWNER DETAILS</b>            |  |
| PROJECT OWNER:                  | Santa Clara Valley Transportation Authority (VTA)      |
| ADDRESS:                        | 3331 N. First Street San Jose, CA 95134                |
| ATTN:                           |  |
| PHONE:                          |  |
| EMAIL:                          |  |
| <b>CONTRACTOR DETAILS</b>       |  |
| CONTRACTOR:                     | [NAME]   |
| ADDRESS:                        |  |
| ATTN:                           |  |
| PHONE:                          |  |
| EMAIL:                          |  |

**ESCAPE Certification:**

I certify that the information provided in the Erosion and Sediment Control Action Plan Element (ESCAPE) is, to the best of my knowledge and belief, true, accurate, and complete and that it will be implemented throughout the project. I further certify that I will notify the VTA and submit revised information if any of the information or conditions documented in this ESCAPE change. I understand that there are significant penalties for submitting false information or for not implementing the ESCAPE. I will retain a copy of the ESCAPE at the project site.

Signature: \_\_\_\_\_

Print/ Type Name: \_\_\_\_\_

Title: \_\_\_\_\_

Date: \_\_\_\_\_

**2. INTRODUCTION**



The preparation of the ESCAPE is based on the principal of Best Management Practices (BMPs) to control and abate the discharge of pollutants in stormwater discharges. This ESCAPE is dynamic, viable, and will be modified and amended when there is a change in the construction or operations which may affect the discharge of stormwaters from the construction site.

**3. PURPOSE**

The purpose of this Erosion and Sedimentation Control Action Plan Element:

1. Identify pollutant sources that may affect the quality of discharges of stormwater associated with the construction activities of the project.
2. Identify, construct, and implement stormwater pollution prevention measures to reduce pollutants in stormwater discharges from the construction site during construction and post construction.
3. Document erosion control, sediment control, wind erosion, tracking control, and non-stormwater management, and waste management and pollution control. Abide by Best Management Practices (BMPs) that must be implemented year-round, as appropriate based on construction activities. The ESCAPE may require modification as the project progresses and as conditions warrant. All modifications to the approved ESCAPE must be submitted to VTA for review and approval.
4. If there is a lease of VTA property for construction purposes, then the termination of that lease is contingent on the close out of all stormwater/MS4 responsibilities as defined in the ESCAPE, objective below. A final walk through should be conducted with VTA MS4 and Real Estate staff to determine if water quality is protected i.e., the site is adequately stabilized and all materials and BMPs are removed.

**4. OBJECTIVE**

The objective of this ESCAPE is to minimize the degradation of off-site receiving waters, to the extent possible, by identifying, constructing, and implementing stormwater pollution prevention BMPs, before, during, and post-construction.

**5. POLLUTANT SOURCE IDENTIFICATION.**

1. List of hazardous materials, chemicals, and other pollutants:

| CATEGORY              | PRODUCT  | POLLUTANTS  |
|-----------------------|--|---|
| Streets and Utilities | Asphalt Paving, Solid and/or Sanitary Waste Concrete | Metals, synthetic organics, high pH runoff, Oil and grease, Nutrients, Gross pollutants |

2. This ESCAPE includes a Water Pollution Control (WPC) Site Map as **Attachment A**.

**6. BEST MANAGEMENT PRACTICES (BMP)**

1. Erosion Control

Erosion control, also referred to as *soil stabilization*, consists of source control measures that are designed to prevent soil particles from detaching and becoming transported in stormwater



runoff. Erosion control BMPs protect the soil surface by covering and/or binding soil particles. This construction project will implement the practices below to provide effective temporary and final erosion control during construction (this includes wind erosion controls).

*Refer to the CASQA Construction BMP Handbook for the applicable fact sheets and update the table as necessary.*

| TABLE 3. EROSION CONTROL BMPs                                     |   |
|---|---|
| BMPs  | State how BMP will be implemented or why BMP is not applicable to project |
| <input type="checkbox"/> EC-1 SCHEDULING                          |   |
| <input type="checkbox"/> EC-2 PRESERVATION OF EXISTING VEGETATION |   |
| <input type="checkbox"/> EC-3 HYDRAULIC MULCH                     |   |
| <input type="checkbox"/> EC-4 HYDROSEEDING                        |   |
| <input type="checkbox"/> EC-5 SOIL BINDERS                        |   |
| <input type="checkbox"/> EC-6 STRAW MULCH                         |   |
| <input type="checkbox"/> EC-7 GEOTEXTILES & MATS                  |   |
| <input type="checkbox"/> EC-8 WOOD MULCHING                       |   |
| <input type="checkbox"/> WE-1 WIND EROSION CONTROL                |   |

## 2. Sediment Controls

Sediment controls are temporary or permanent structural measures that are intended to complement the selected erosion control measures and reduce sediment discharges from active construction areas. Sediment controls are designed to intercept and settle out soil particles that have been detached and transported by the force of water. This construction project will implement the practices below to provide effective sediment control during construction (this includes track out controls).

*Refer to the CASQA Construction BMP Handbook for the applicable fact sheets and update the table as necessary.*

| TABLE 4. SEDIMENT CONTROL BMPs                                       |   |
|--|---|
| BMPs   | State how BMP will be implemented or why BMP is not applicable to project |
| <input type="checkbox"/> SE-1 SILT FENCE                             |   |
| <input type="checkbox"/> SE-4 CHECK DAMS                             |   |
| <input type="checkbox"/> SE-5 FIBER ROLLS                            |   |
| <input type="checkbox"/> SE-6 OR SE-8 GRAVEL/SANDBAG BERMS           |   |
| <input type="checkbox"/> SE-7 STREET SWEEPING AND VACUUMING          |   |
| <input type="checkbox"/> SE-10 STORM DRAIN INLET PROTECTION          |   |
| <input type="checkbox"/> TC-1 STABILIZED CONSTRUCTION ENTRANCE/ EXIT |   |

## 3. Non-Stormwater Controls and Management



All construction equipment utilized on-site shall be regularly inspected for leaks and repaired immediately. Petroleum distillate fueled and lubricated equipment shall be properly maintained to prevent leakage of such materials. Servicing of such equipment shall be performed in such a manner that all petroleum distillate materials do not come into contact with the ground and shall be disposed of properly offsite.

Non-stormwater management at this site includes prevention of contamination from the following sources: *Update based on project-specific information.*

- Vehicle fluids, including oil, grease, petroleum, and coolants;
- Vehicle equipment and wash water;
- Asphaltic emulsions associated with asphalt-concrete paving operations;
- Chemical curing compounds and cure water from concrete curing;
- Concrete washout water;
- Water and solid waste from concrete finishing;
- Paints, solvents, thinners, acids;
- Accumulated sediment from dewatering operations;
- Portable toilet waste; and
- General litter.

This construction project will implement the practices below to provide effective non-stormwater control during construction.

*Refer to the CASQA Construction BMP Handbook for the applicable fact sheets and update the table as necessary.*

| TABLE 5. NON-STORMWATER CONTROL BMPs                         |   |
|--|---|
| BMPs   | State how BMP will be implemented or why BMP is not applicable to project |
| <input type="checkbox"/> NS-1 WATER CONSERVATION PRACTICES   |   |
| <input type="checkbox"/> NS-2 DEWATERING OPERATIONS          |   |
| <input type="checkbox"/> NS-3 PAVING AND GRINDING OPERATIONS |   |
| <input type="checkbox"/> NS-4 TEMPORARY STREAM CROSSING      |   |
| <input type="checkbox"/> NS-5 CLEAR WATER DIVERISON          |   |
| <input type="checkbox"/> NS-6 ILLICIT CONNECTION/ DISCHARGE  |   |
| <input type="checkbox"/> NS-7 POTABLE WATER/IRRIGATION       |   |
| <input type="checkbox"/> NS-8 VEHICLE AND EQUIPMENT CLEANING |   |
| <input type="checkbox"/> NS-9 VEHICILE AND EQUIPMENT FUELING |   |



|  |  |
|--|--|
| <input type="checkbox"/> NS-10 VEHICLE AND EQUIPMENT MAINTENANCE |  |
| <input type="checkbox"/> NS-12 CONCRETE CURING                   |  |
| <input type="checkbox"/> NS-13 CONCRETE FINISHING                |  |
| <input type="checkbox"/> NS-14 MATERIAL OVER WATER               |  |
| <input type="checkbox"/> NS-15 DEMOLITION ADJACENT TO WATER      |  |

4. Waste Management and Materials Pollution Control

Materials management control practices consist of implementing procedural and structural BMPs for handling, storing, and using construction materials to prevent the release of those materials into stormwater discharges. The amount and type of construction materials to be utilized at the Site will depend upon the type of construction and the length of the construction period. The materials may be used continuously, such as fuel for vehicles and equipment, or the materials may be used for a discrete period, such as soil binders for temporary stabilization. This construction project will implement the practices below to provide effective waste management during construction.

*Refer to the CASQA Construction BMP Handbook for the applicable fact sheets and update the table as necessary.*

| TABLE 6. WASTE MANAGEMENT AND MATERIALS POLLUTION CONTROL BMPs |   |
|--|---|
| BMPs   | State how BMP will be implemented or why BMP is not applicable to project |
| <input type="checkbox"/> WM-1 MATERIAL DELIVERY AND STORAGE    |   |
| <input type="checkbox"/> WM-2 MATERIAL USE                     |   |
| <input type="checkbox"/> WM-3 STOCKPILE MANAGEMENT             |   |
| <input type="checkbox"/> WM-4 SPILL PREVENTION AND CONTROL     |   |
| <input type="checkbox"/> WM-5 SOLID WASTE MANAGEMENT           |   |
| <input type="checkbox"/> WM-6 HAZARDOUS WASTE MANAGEMENT       |   |
| <input type="checkbox"/> WM-7 CONTAMINATED SOIL MANAGEMENT     |   |
| <input type="checkbox"/> WM-8 CONCRETE WASTE MANAGEMENT        |   |
| <input type="checkbox"/> WM-9 SANITARY/SEPTIC WASTE MANAGEMENT |   |
| <input type="checkbox"/> WM-10 LIQUID WASTE MANAGEMENT         |   |

5. Waste Disposal

All wastes, including waste oil and other equipment wastes, shall be disposed of off-site in compliance with federal, state, and local regulations. Proper disposal of construction related wastes and equipment wastes is the responsibility of the contractor. Contractor is required to submit detailed information regarding waste management and disposal.



**7. SPILL PREVENTION AND ACCIDENTAL DISCHARGES**

Accidental discharges can be the greatest cause of pollution of the stormwater discharges. All emergency spill controls and measures shall be performed as follows:

*Update based on project-specific information including spill kit location, worker training, and phone numbers for local spill control emergency responders in the event of a larger spill.*

1. Notify the Resident Engineer/Inspector immediately.
2. Contain the spread of spills.
3. If the spills occur on paved or impermeable surfaces, clean them up using “dry” methods (absorbent materials, cat litter, and/or rags). Contain the spills by encircling with absorbent materials and do not let them spread widely.
4. Handle, store, and dispose of soiled/spent absorbent materials in accordance with applicable laws.

Non-stormwater discharges and spills that reach the storm drain must be reported to the VTA Compliance Officer and may require further reporting to the VTA Stormwater Program, Regional Water Quality Control Board, and/or California Department of Fish and Wildlife by VTA.

**8. MAINTENANCE, INSPECTION REPORTS, AND BMP REPAIR**

All ESCAPE Inspections will be captured in the CloudCompli (www.cloudcompli.com) inspection software within 24-hours of performing the inspection. Contractor will purchase licenses at a cost of \$1,200 per user per year from CloudCompli as necessary to meet this requirement, so they can be given a log-on identification and password to access the VTA’s CloudCompli project dashboard. All (Verify frequency with the VTA Compliance Officer) site inspections, daily visual monitoring of track-out and trash areas, and BMP inspections before and after a storm event, are required. All deficiencies must be corrected within 72-hours.

Contractor is responsible for implementation of the ESCAPE. VTA will oversee compliance. Many of the storm pollution control BMPs require ongoing inspection, maintenance and repair to function properly.

**9. RECORD KEEPING AND REPORTING**

All ESCAPE amendments will be submitted to VTA for approval prior to incorporation.

During the course of construction, unanticipated changes may occur, such as schedule changes, phasing changes, and staging area modifications. The ESCAPE must be revised to reflect these changes and must also be revised when a new BMP is needed. All revisions will be submitted to VTA for approval prior to incorporation.

All monitoring reports will performed and made available in CloudCompli.

**10. PROJECT COMPLIANCE PERMITS AND SPECIFICATIONS**

*Include a list and attach any applicable permits that are required for this project.*



## ATTACHMENT A

### Temporary Water Pollution Control Drawings (WPCD) & Details

The ESCAPE includes Temporary Water Pollution Control Drawings/Site Plan/Layout Sheets (Designer to customize the following list as applicable for the project.) as Attachment A that shows the following:

- Areas of soil disturbance and stock piles
- Drainage patterns before and after construction (i.e. gutter, inlets...)
- Locations of erosion controls such as: bonded fiber matrix, erosion control blanket, etc.
- Locations of sediment controls such as: silt fence, fiber rolls, sandbags, drain inlet protection, concrete washouts, check dams, rock entrance/exit, etc.
- Areas and plan for material storage and concrete washouts.
- Staging, trailer, and construction equipment locations.
- Locations of any leased portions of VTA property for staging or trailers if not associated with the project locations.
- Show on the plan sheet(s) the locations of proposed final stabilization BMPs and post construction stormwater treatment.

Contractor to update for specific means and methods. Use red pen or PDF editor to show contractor's edits to the locations of proposed temporary construction activity BMPs. Some BMPs may be included as notes on the site plan.





**ATTACHMENT O:**

SAMPLE WATER POLLUTION CONTROL  
DRAWINGS

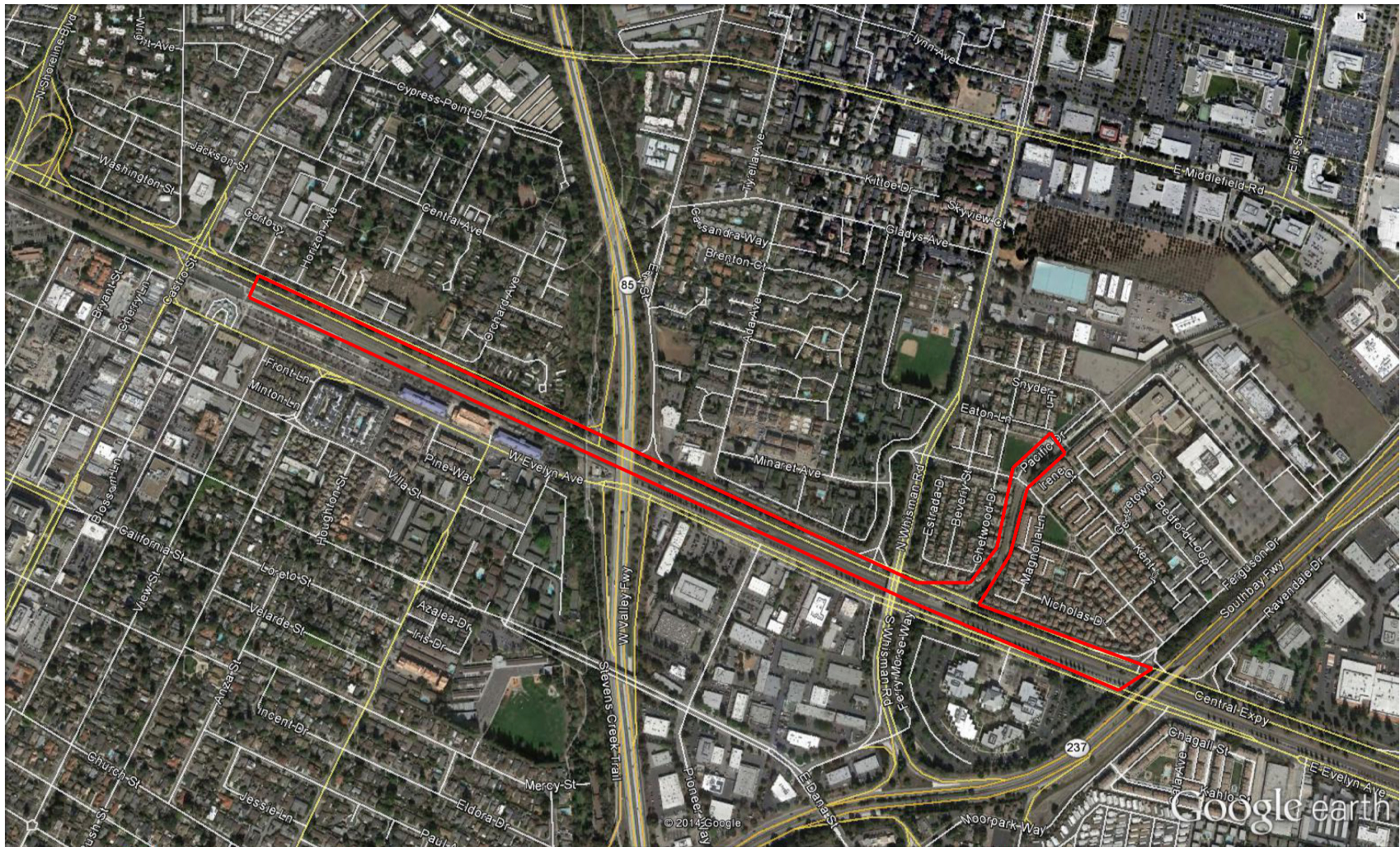

## LEGEND

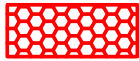

BONDED FIBER MATRIX (BFM)

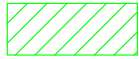

TEMPORARY COVER AND ROLLED EROSION CONTROL PRODUCTS



SAMPLING LOCATION



TEMPORARY FIBER ROLLS



TEMPORARY SILT FENCE



APPROXIMATE STORMWATER FLOW DIRECTION



TEMPORARY DRAINAGE INLET PROTECTION



TEMPORARY CONSTRUCTION ENTRANCE/EXIT AND STREET SWEEPING



STOCKPILE MANAGEMENT/COVER STOCKPILE



SPILL PREVENTION AND CONTROL



CONCRETE WASTE MANAGEMENT



SANITARY SEPTIC WASTE MANAGEMENT



WIND EROSION CONTROL



MATERIAL DELIVERY AND STORAGE



TEMPORARY CHECK DAMS

### NOTES:

- 1) THE PROJECT IS A RISK LEVEL \_\_\_ SITE AND ALL ACTIVITIES WILL COMPLY WITH THE CONSTRUCTION GENERAL PERMIT (CGP), AS WELL AS THE CITY OF \_\_\_\_\_ AND VTA REQUIREMENTS.
- 2) PRIOR TO THE START OF CONSTRUCTION, THE CONSTRUCTION LIMITS WILL BE DELINEATED AND APPROPRIATE PERIMETER SEDIMENT CONTROL BMPs WILL BE INSTALLED WHERE RUNOFF HAS THE POTENTIAL FOR OFF-SITE DISCHARGE. THE QUANTITY AND LOCATION OF PERIMETER CONTROL BMPs WILL BE FIELD VERIFIED BY THE PROJECT QUALIFIED SWPPP PRACTITIONER (QSP) AND BMP LOCATIONS WILL BE MODIFIED ACCORDINGLY AS SITE CONDITIONS CHANGE.
- 3) STABILIZED ENTRANCE/EXITS WILL BE INSTALLED BETWEEN PAVED AND UNPAVED AREAS INTO THE RIGHT OF WAY (ROW) TO MINIMIZE POTENTIAL OFF-SITE TRACK OUT AND PER THE CGP REQUIREMENTS. ENTRANCE/EXIT WILL BE STABILIZED WITH A COMBINATION OF ROCK AGGREGATE UNDERLINED WITH GEOTEXTILE FABRIC, TEMPORARY STEEL RUMBLE PLATES AND OR EQUIVALENT MEASURES. ENTRANCE/EXITS WILL BE GRADED BACK INTO THE PROJECT SITE TO MINIMIZE POTENTIAL OFF-SITE DISCHARGES. ENTRANCE/EXITS WILL BE ASSESSED FREQUENTLY AND ROCK REFRESHED OR RUMBLE PLATES CLEANED OR REPLACED AS NECESSARY.
- 4) STREET SWEEPING ACTIVITIES WILL BE PERFORMED A MINIMUM OF DAILY, CONTINUOUSLY DURING EARTH MOVING ACTIVITIES, AND ALWAYS PRIOR TO RAIN EVENTS TO ABATE TRACK OUT.
- 5) ALL EXISTING STORM DRAIN INLETS OR DRAINAGE CONVEYANCES WITHIN OR NEAR THE PROJECT ROW WILL BE FIELD VERIFIED AND PROTECTED WITH SEDIMENT CONTROL BMPs PRIOR TO THE START OF CONSTRUCTION. ROUTINE AND PRE-STORM MAINTENANCE WILL BE CONDUCTED AT ALL STORM DRAIN INLETS TO ENSURE BMPs ARE IN GOOD CONDITION AND ARE EFFECTIVE.
- 6) APPROPRIATE ACTIONS WILL BE TAKEN TO MINIMIZE POTENTIAL NUISANCE DUST DURING LAND DISTURBING ACTIVITIES. THE DISTURBED AREAS WILL BE WATERED SUFFICIENTLY DAILY AND AS NEEDED DAILY TO MINIMIZE DUST EMISSIONS FROM LEAVING THE PROJECT.
- 7) DISTURBED SOIL AREAS WILL BE STABILIZED WITH APPROPRIATE EROSION CONTROL BMPs PER THE SWPPP PRIOR TO RAIN EVENTS, DURING INACTIVITY, AND AS AREAS ARE COMPLETED/ RETURNED TO PRE- CONSTRUCTION CONDITIONS.
- 8) TRASH MATERIALS WILL BE STORED IN WATER TIGHT CONTAINERS THAT WILL BE COVERED AT THE END OF EACH DAY AND PRIOR TO ALL RAIN EVENTS.
- 9) EQUIPMENT WILL BE STORED IN A DESIGNATED LOCATION AT THE END OF EACH WORK DAY. THIS LOCATION, AS WELL AS THE MAIN STORAGE/LAYDOWN YARD WILL HAVE SPILL CLEAN UP KITS ON-SITE AND AVAILABLE FOR USE AT ALL TIMES.
- 10) THE PROJECT WILL BE INSPECTED REGULARLY (I.E. WEEKLY WHEN NO RAIN, PRE & POST RAIN EVENTS) BY THE DESIGNATED TRAINED ON-SITE STAFF. INSPECTIONS WILL BE PERFORMED TO ASSESS SITE CONDITIONS AND THE EFFECTIVENESS OF THE INSTALLED BMPs. ALL INSPECTIONS WILL DOCUMENT SITE OBSERVATIONS, IDENTIFIED DEFICIENCIES, AND ALL IMPLEMENTED CORRECTIVE MEASURES.
- 11) NUMERIC ACTION LEVEL (NAL) RUNOFF SAMPLING WILL BE PERFORMED DURING QUALIFY RAIN EVENTS (QRES). DISCHARGE LOCATIONS WILL BE FIELD DETERMINED BY THE PROJECT QSP AND/OR TRAINED ON-SIT STAFF BASED ON FIELD CONDITIONS AND THE OBSERVANCE OF OFF-SITE DISCHARGE FROM THE PROJECT (RUN-ON ASSESSMENT WILL BE CONDUCTED). A MINIMUM OF 3 SAMPLES PER DAY OR 1 SAMPLE PER DISCHARGE LOCATION (IF MORE THAN 3 DISCHARGE LOCATIONS ARE IDENTIFIED) WILL BE TAKEN PER RISK LEVEL \_\_\_ REQUIREMENTS. DAILY AVERAGES MUST MEET RISK LEVEL \_\_\_ REQUIREMENTS FOR TURBIDITY AND PH.
- 12) ALL BMPs SHOWN ON THE MAP ARE APPROXIMATE LOCATIONS, AND MODIFICATIONS TO EXACT LOCATIONS WILL BE BASED ON PRE CONSTRUCTION SURVEY, DISTURBED AREAS, PHASE OF CONSTRUCTION, AND THE SITE QSP'S PROFESSIONAL JUDGEMENT.
- 13) THE PROJECT'S SITE MAP WILL BE UPDATED AS CONSTRUCTION PROGRESSES TO REFLECT THE CURRENT SITE CONDITIONS, IMPLEMENTED BMPs AND MODIFICATIONS BASED ON FIELD CHANGES PRIOR TO AND DURING THE RAINY SEASON.

CENTRAL EXPRESSWAY

FIELD VERIFY AND ESTABLISH PERIMETER  
SEDIMENT CONTROL BMP AT PROJECT LIMITS  
FOR ALL AREAS WITH POTENTIAL OFF-SITE  
DISCHARGE DURING CONSTRUCTION

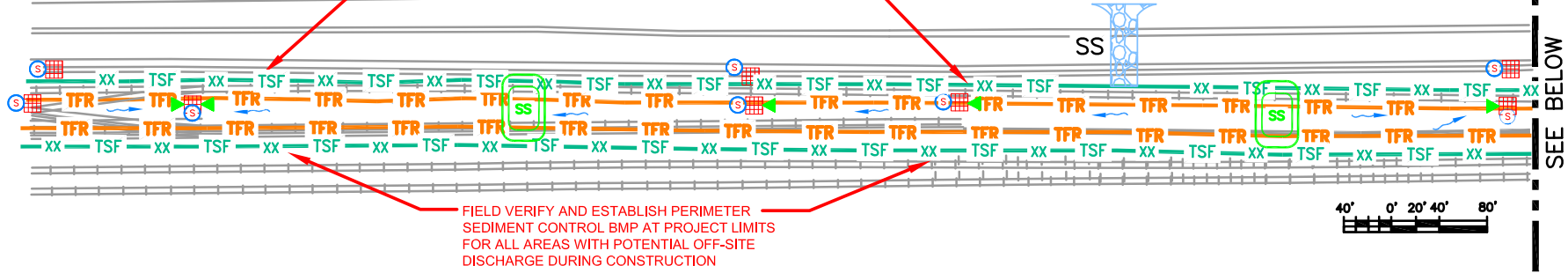

FIELD VERIFY AND ESTABLISH PERIMETER  
SEDIMENT CONTROL BMP AT PROJECT LIMITS  
FOR ALL AREAS WITH POTENTIAL OFF-SITE  
DISCHARGE DURING CONSTRUCTION

SEE ABOVE

FIELD VERIFY AND ESTABLISH PERIMETER  
SEDIMENT CONTROL BMP AT PROJECT LIMITS  
FOR ALL AREAS WITH POTENTIAL OFF-SITE  
DISCHARGE DURING CONSTRUCTION

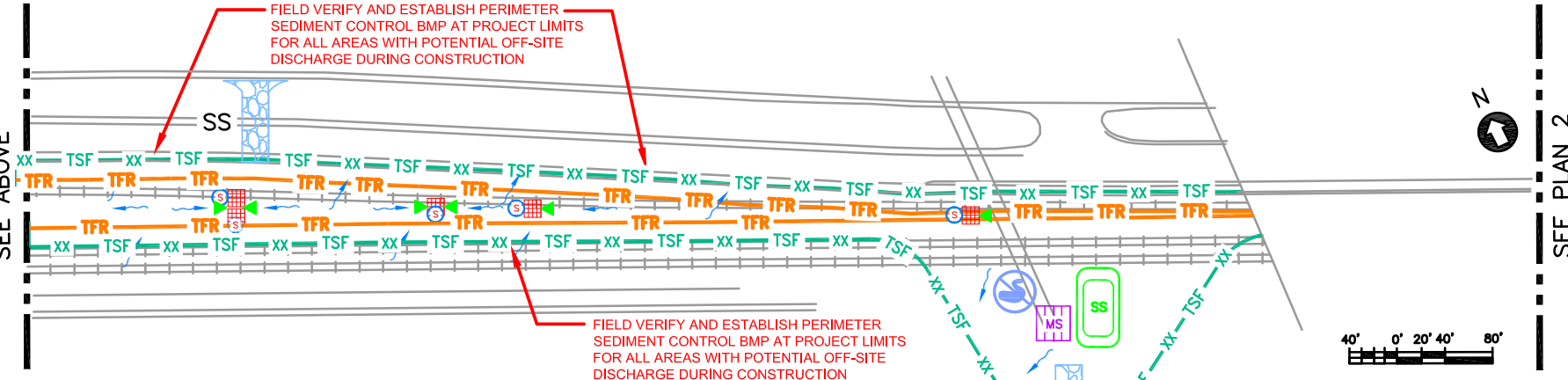

FIELD VERIFY AND ESTABLISH PERIMETER  
SEDIMENT CONTROL BMP AT PROJECT LIMITS  
FOR ALL AREAS WITH POTENTIAL OFF-SITE  
DISCHARGE DURING CONSTRUCTION

NOTE:  
FOR NOTES AND LEGEND SEE TEMPORARY WATER  
POLLUTION NOTES AND LEGEND DRAWING.

AS NEEDED:

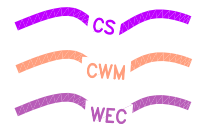

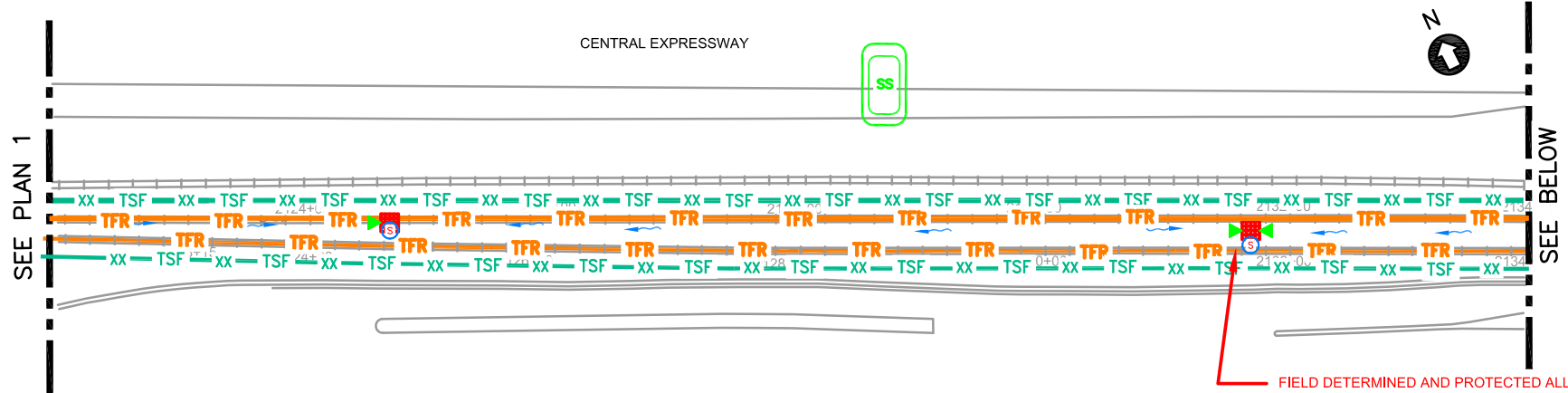





FIELD DETERMINED AND PROTECTED ALL STORM DRAIN INLETS WITHIN CONSTRUCTION ROW AREA

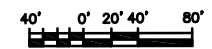

FIELD DETERMINED AND PROTECTED ALL STORM DRAIN INLETS WITHIN CONSTRUCTION ROW AREA

NOTE:  
FOR NOTES AND LEGEND SEE TEMPORARY WATER POLLUTION NOTES AND LEGEND DRAWING.



- AS NEEDED:
-  CS
  -  CWM
  -  WEC

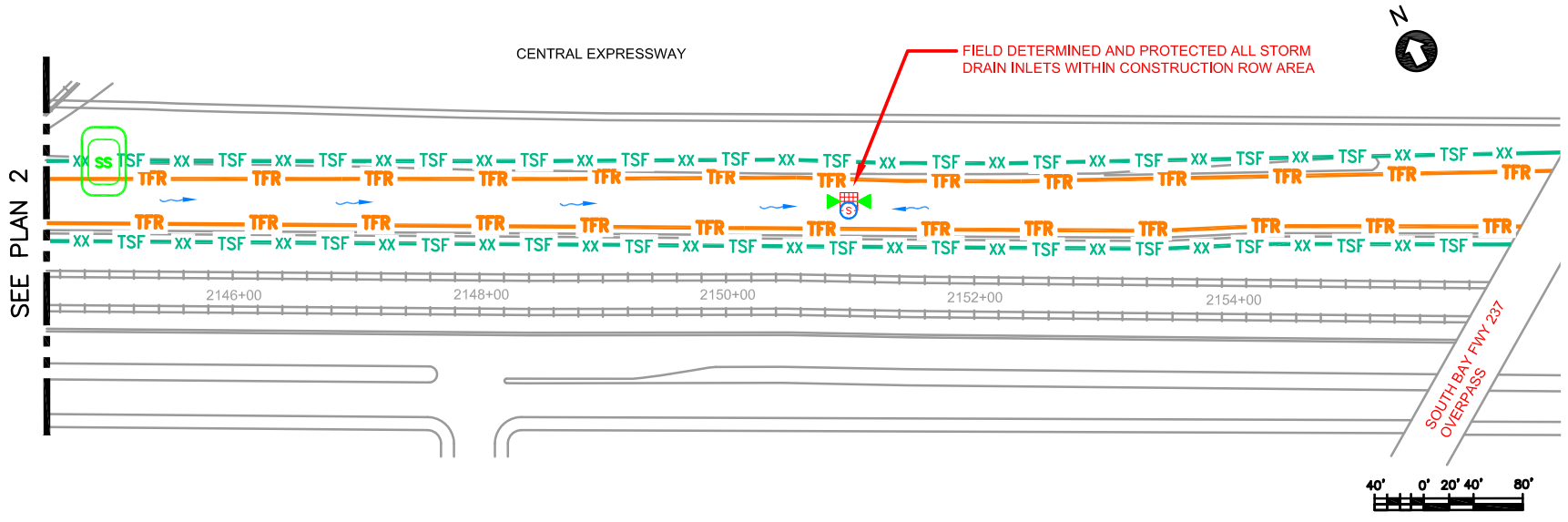

NOTE:  
 FOR NOTES AND LEGEND SEE TEMPORARY WATER  
 POLLUTION NOTES AND LEGEND DRAWING.



## LEGEND

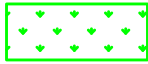

HYDROSEEDING



FIBER ROLLS



APPROXIMATE STORMWATER  
FLOW DIRECTION

### NOTES:

- 1) THE PROJECT IS A RISK LEVEL \_\_\_ SITE AND ALL ACTIVITIES WILL COMPLY WITH THE CONSTRUCTION GENERAL PERMIT (CGP), AS WELL AS THE CITY OF \_\_\_\_\_ AND VTA REQUIREMENTS.
- 2) PRIOR TO THE START OF CONSTRUCTION, THE CONSTRUCTION LIMITS WILL BE DELINEATED AND APPROPRIATE PERIMETER SEDIMENT CONTROL BMPs WILL BE INSTALLED WHERE RUNOFF HAS THE POTENTIAL FOR OFF-SITE DISCHARGE. THE QUANTITY AND LOCATION OF PERIMETER CONTROL BMPs WILL BE FIELD VERIFIED BY THE PROJECT QUALIFIED SWPPP PRACTITIONER (QSP) AND BMP LOCATIONS WILL BE MODIFIED ACCORDINGLY AS SITE CONDITIONS CHANGE.
- 3) STABILIZED ENTRANCE/EXITS WILL BE INSTALLED BETWEEN PAVED AND UNPAVED AREAS INTO THE RIGHT OF WAY (ROW) TO MINIMIZE POTENTIAL OFF-SITE TRACK OUT AND PER THE CGP REQUIREMENTS. ENTRANCE/EXIT WILL BE STABILIZED WITH A COMBINATION OF ROCK AGGREGATE UNDERLINED WITH GEOTEXTILE FABRIC, TEMPORARY STEEL RUMBLE PLATES AND OR EQUIVALENT MEASURES. ENTRANCE/EXITS WILL BE GRADED BACK INTO THE PROJECT SITE TO MINIMIZE POTENTIAL OFF-SITE DISCHARGES. ENTRANCE/EXITS WILL BE ASSESSED FREQUENTLY AND ROCK REFRESHED OR RUMBLE PLATES CLEANED OR REPLACED AS NECESSARY.
- 4) STREET SWEEPING ACTIVITIES WILL BE PERFORMED A MINIMUM OF DAILY, CONTINUOUSLY DURING EARTH MOVING ACTIVITIES, AND ALWAYS PRIOR TO RAIN EVENTS TO ABATE TRACK OUT.
- 5) ALL EXISTING STORM DRAIN INLETS OR DRAINAGE CONVEYANCES WITHIN OR NEAR THE PROJECT ROW WILL BE FIELD VERIFIED AND PROTECTED WITH SEDIMENT CONTROL BMPs PRIOR TO THE START OF CONSTRUCTION. ROUTINE AND PRE-STORM MAINTENANCE WILL BE CONDUCTED AT ALL STORM DRAIN INLETS TO ENSURE BMPs ARE IN GOOD CONDITION AND ARE EFFECTIVE.
- 6) APPROPRIATE ACTIONS WILL BE TAKEN TO MINIMIZE POTENTIAL NUISANCE DUST DURING LAND DISTURBING ACTIVITIES. THE DISTURBED AREAS WILL BE WATERED SUFFICIENTLY DAILY AND AS NEEDED DAILY TO MINIMIZE DUST EMISSIONS FROM LEAVING THE PROJECT.
- 7) DISTURBED SOIL AREAS WILL BE STABILIZED WITH APPROPRIATE EROSION CONTROL BMPs PER THE SWPPP PRIOR TO RAIN EVENTS, DURING INACTIVITY, AND AS AREAS ARE COMPLETED/ RETURNED TO PRE- CONSTRUCTION CONDITIONS.
- 8) TRASH MATERIALS WILL BE STORED IN WATER TIGHT CONTAINERS THAT WILL BE COVERED AT THE END OF EACH DAY AND PRIOR TO ALL RAIN EVENTS.
- 9) EQUIPMENT WILL BE STORED IN A DESIGNATED LOCATION AT THE END OF EACH WORK DAY. THIS LOCATION, AS WELL AS THE MAIN STORAGE/LAYDOWN YARD WILL HAVE SPILL CLEAN UP KITS ON-SITE AND AVAILABLE FOR USE AT ALL TIMES.
- 10) THE PROJECT WILL BE INSPECTED REGULARLY (I.E. WEEKLY WHEN NO RAIN, PRE & POST RAIN EVENTS) BY THE DESIGNATED TRAINED ON-SITE STAFF. INSPECTIONS WILL BE PERFORMED TO ASSESS SITE CONDITIONS AND THE EFFECTIVENESS OF THE INSTALLED BMPs. ALL INSPECTIONS WILL DOCUMENT SITE OBSERVATIONS, IDENTIFIED DEFICIENCIES, AND ALL IMPLEMENTED CORRECTIVE MEASURES.
- 11) NUMERIC ACTION LEVEL (NAL) RUNOFF SAMPLING WILL BE PERFORMED DURING QUALIFY RAIN EVENTS (QRES). DISCHARGE LOCATIONS WILL BE FIELD DETERMINED BY THE PROJECT QSP AND/OR TRAINED ON-SIT STAFF BASED ON FIELD CONDITIONS AND THE OBSERVANCE OF OFF-SITE DISCHARGE FROM THE PROJECT (RUN-ON ASSESSMENT WILL BE CONDUCTED). A MINIMUM OF 3 SAMPLES PER DAY OR 1 SAMPLE PER DISCHARGE LOCATION (IF MORE THAN 3 DISCHARGE LOCATIONS ARE IDENTIFIED) WILL BE TAKEN PER RISK LEVEL \_\_\_ REQUIREMENTS. DAILY AVERAGES MUST MEET RISK LEVEL \_\_\_ REQUIREMENTS FOR TURBIDITY AND PH.
- 12) ALL BMPs SHOWN ON THE MAP ARE APPROXIMATE LOCATIONS, AND MODIFICATIONS TO EXACT LOCATIONS WILL BE BASED ON PRE CONSTRUCTION SURVEY, DISTURBED AREAS, PHASE OF CONSTRUCTION, AND THE SITE QSP'S PROFESSIONAL JUDGEMENT.
- 13) THE PROJECT'S SITE MAP WILL BE UPDATED AS CONSTRUCTION PROGRESSES TO REFLECT THE CURRENT SITE CONDITIONS, IMPLEMENTED BMPs AND MODIFICATIONS BASED ON FIELD CHANGES PRIOR TO AND DURING THE RAINY SEASON.

CENTRAL EXPRESSWAY

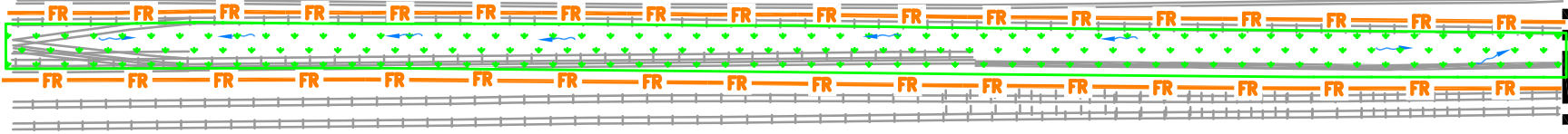

SEE BELOW

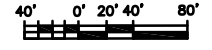

SEE ABOVE

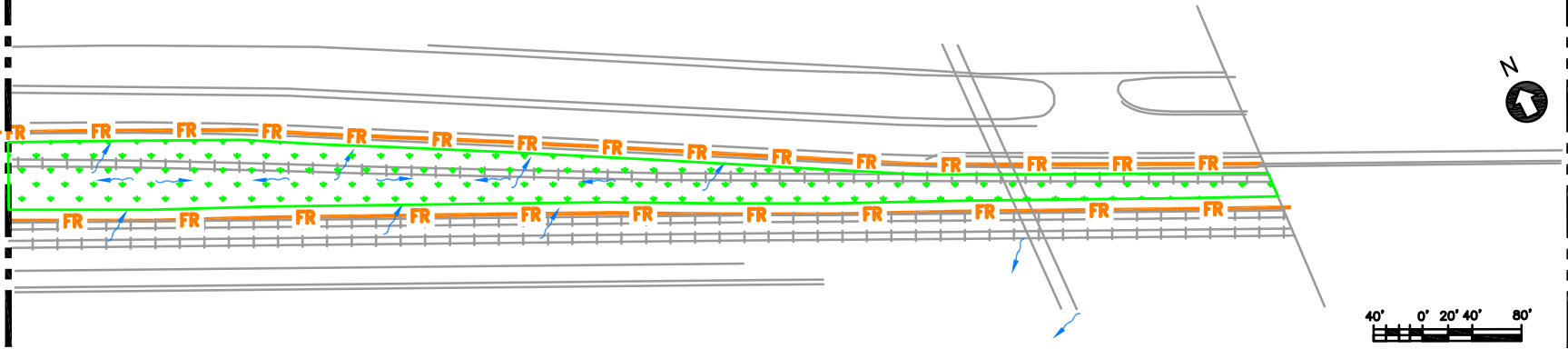

SEE PLAN 2

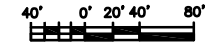

NOTE:  
FOR NOTES AND LEGEND SEE EROSION CONTROL  
PLAN NOTES AND LEGEND DRAWING.

EROSION CONTROL - PLAN - 1

PROJECT LOCATION

MAY 14, 2019



CENTRAL EXPRESSWAY



SEE PLAN 1

SEE BELOW

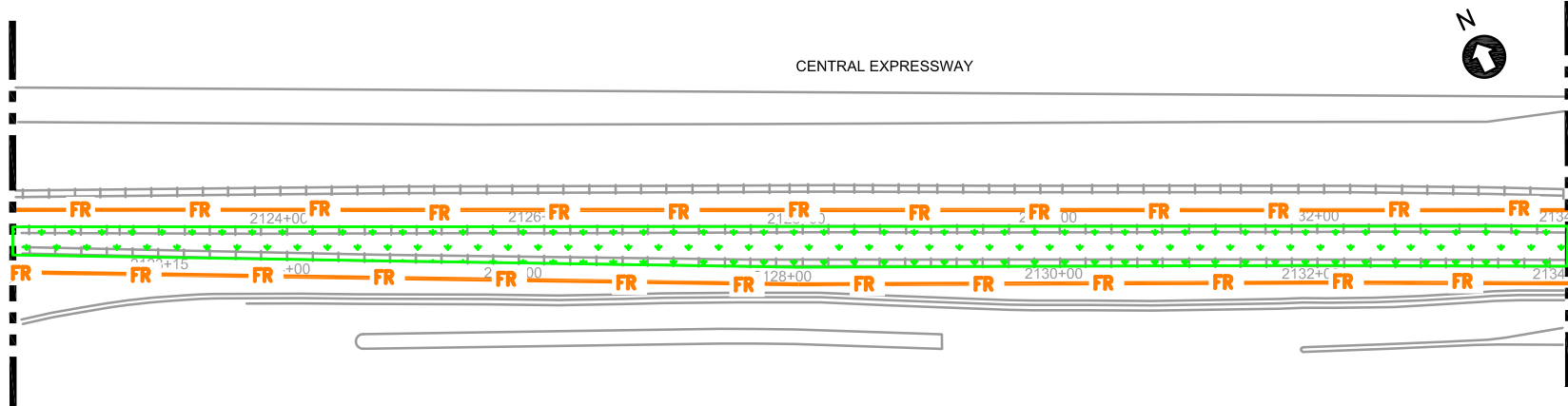

SEE ABOVE

SEE PLAN 3

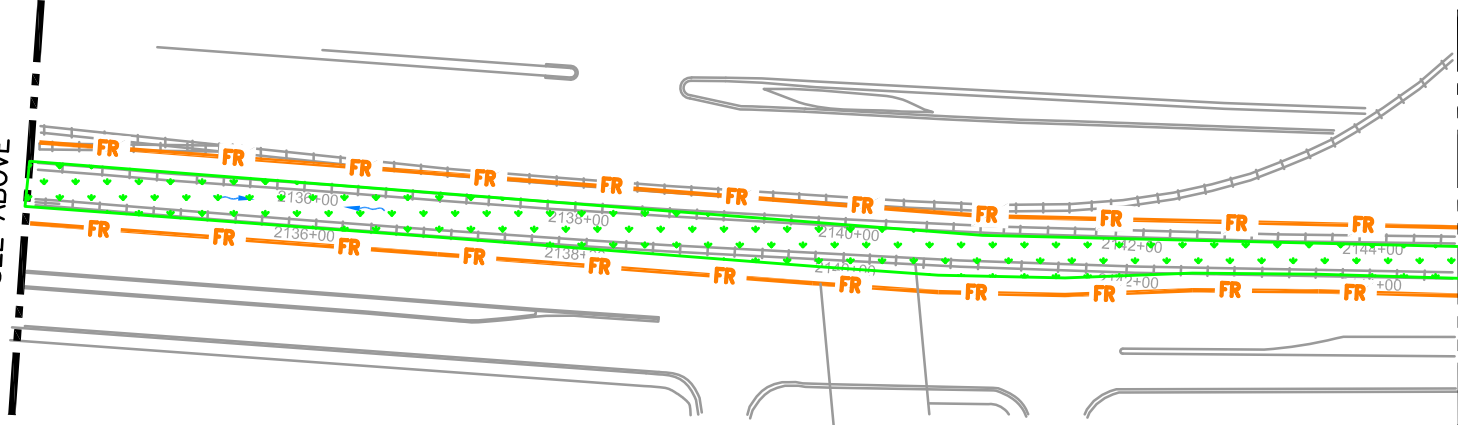

NOTE:  
FOR NOTES AND LEGEND SEE EROSION CONTROL  
PLAN NOTES AND LEGEND DRAWING.

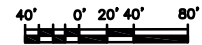

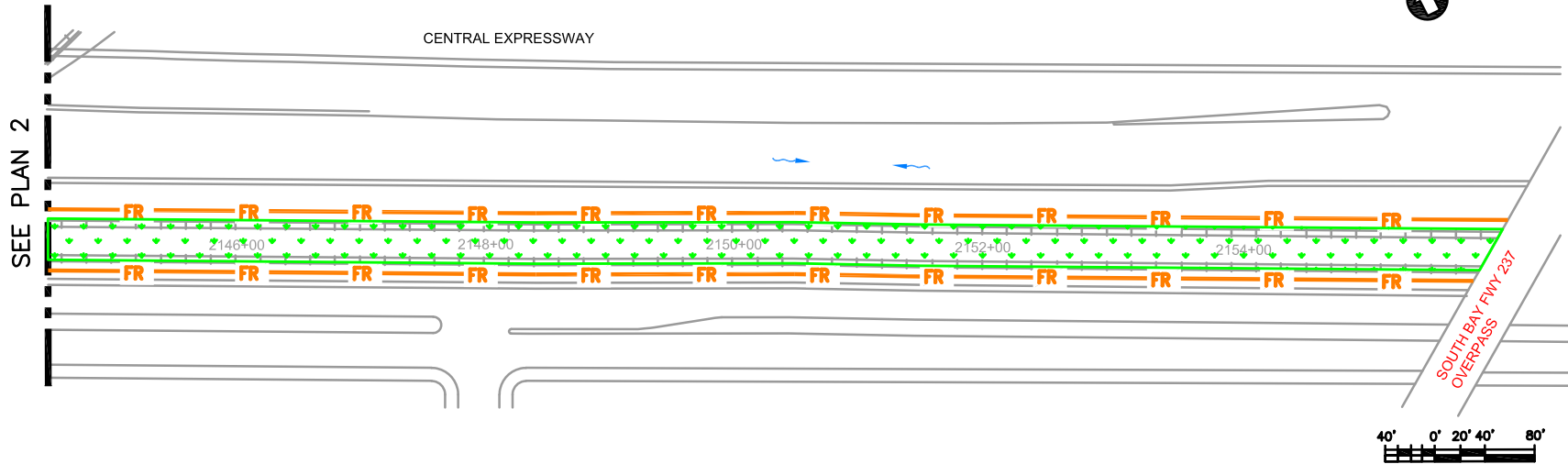

**NOTE:**  
 FOR NOTES AND LEGEND SEE EROSION CONTROL  
 PLAN NOTES AND LEGEND DRAWING.



## **ATTACHMENT P:**

### VTA LANDSCAPING AND STORM WATER REQUIREMENTS FREQUENTLY ASKED QUESTIONS



## Why use this manual?

The Statewide Construction General Permit for Stormwater (CGP) and the Municipal Separate Storm Sewer System (MS4) Phase II permit contain regulations for VTA's capital and facilities projects, including new and redevelopment projects. In addition, VTA's Sustainability Policy requires that native and drought tolerant plants be used on VTA projects.

The goals of the permit requirements are to:

1. Prevent impacts to local waterways from construction and post-construction project runoff, and;
2. Eliminate or minimize any additional runoff from increased impervious areas as a result of the project.

This is accomplished by requiring during-construction best management practices (BMPs), source control measures, runoff reduction measures, and

**Figure1:** Outline of Stormwater Design Process

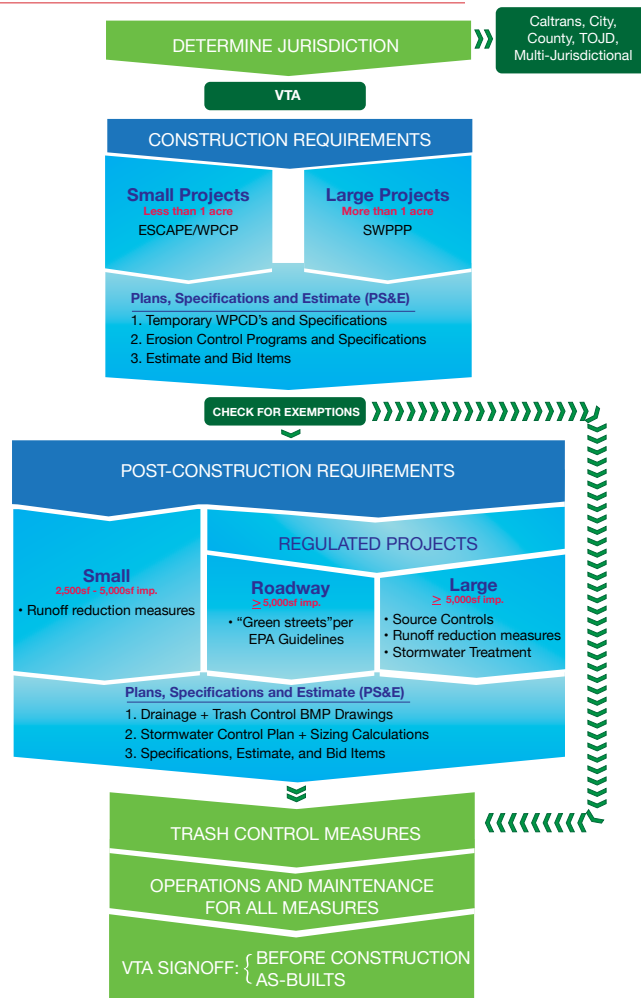



stormwater treatment to be incorporated into construction documents, contractor construction activities, and operation & maintenance (O&M) elements. To the right is a visual guideline of the stormwater design process.

## What projects must comply with the regulations?

All projects must comply with the permit requirements and prevent silt, sediment and other pollutants from leaving the project site. There are different size criteria for different types of projects, and during-construction and post-construction requirements, as follows:

- Construction Projects:
  - <1 acre must prepare an Erosion and Sediment Control Action Plan Element (ESCAPE) or Water Pollution Control Plan (WPCP)
  - $\geq 1$  acre must include a Stormwater Pollution Prevent Plan (SWPPP)
- Post-Construction:
  - Development projects that create and/or replace  $\geq 2,500$  square feet of impervious surface
  - Roadway projects that create and/or replace  $\geq 5,000$  square feet of impervious surface
  - Projects that initiate design on or after June 30, 2015

## What projects are exempted?

- Projects that initiate design before June 30, 2015
- Interior remodels
- Impervious trails built to direct storm water runoff to adjacent vegetated areas
- Trails, sidewalks, and bike lanes made with permeable materials
- Routine maintenance and repair projects, such as:
  - Pavement or asphalt resurfacing within the existing footprint
  - Sidewalk replacement within an existing footprint
  - Routine replacement/repair of damaged pavement/asphalt
  - Maintenance, repair, and replacement work on existing underground utilities
  - Building roof or exterior wall surface replacement

## How is VTA complying with the During-Construction requirements?

All new construction projects must comply with the current MS4 permit and VTA's Sustainable Landscaping Policy. All new construction projects must comply with the current CGP permit through:

- Preparation of the required SWPPP (projects that disturb more than 1 acre) or ESCAPE/WPCP (for all smaller VTA projects)
- Inclusion of construction BMPs to address both erosion control (keeping soils in place) and sediment control (stopping soils that have migrated offsite)
- Inclusion of the costs of construction BMPs in the contract bid/pay items
- Evaluation of the during-construction conditions and project staging/phasing and inclusion of the temporary BMPs needed during construction in the Water Pollution Control Drawings
- Inclusion of permanent BMPs that address site stabilization and erosion control in Final Erosion Control Drawings
- Inclusion of inspection frequencies as outlined in the Manual

## How is VTA complying with the Post-Construction requirements?

If projects exceed the threshold of 2,500 square feet of impervious surface, one of the following Templates and related Checklists are required to be filled out and submitted to PED:





- Stormwater Control Plan for Small Projects (2,500-5,000 sq. ft)
  - Includes at least one runoff reduction measure
- Stormwater Control Plan for Regulated Projects (>5,000 sq. ft)
  - Includes source control measures, runoff reduction measures, and stormwater treatment (as needed)
- All new stormwater infrastructure must be captured in CAD and GIS
- If a Roadway Project, include “Complete Streets” elements
- The Checklist and Stormwater Control Plans will be reviewed by VTA PED and VTA Environmental Programs. Any required changes to meet the requirements will be communicated to designers by the PM.
- Once project design is completed and prior to advertising for bid, VTA PED will document to VTA Environmental Programs personnel that the post-construction measures are in place and that O&M requirements are met through the VTA Signoff form.

## What are Low Impact Design Strategies?

Compliance with post-construction requirements includes integration of Low Impact Design (LID) strategies from the conceptual stages of a project; these include:

- Source Control Measures – control pollution-generating activities by requiring the design, construction, and O&M of specified activities and sources to meet Best Management Practices (BMPs). These apply to Regulated projects only.
- Runoff Reduction Measures – reduce the amount of runoff from related construction. These apply to all projects.
- Stormwater Treatment Measures and Sizing Criteria – these numeric sizing requirements are included in the permit and outline requirements to infiltrate, evapotranspire, and/or biotreat runoff, based on the 85<sup>th</sup> percentile storm event.



## What is a Post-Construction Water Balance?

The Post-Construction Water Balance is a tool used to demonstrate that there is an **equal pre- and post-construction runoff from a project**. Designers use this tool to quantify that their selected runoff reduction and site design measures sufficiently mitigate the amount of impervious surfaces they have added into a Regulated Project, to meet the design criteria in the MS4 permit.

- To determine the post-construction water balance for the project, use the State's Storm Water Multiple Application & Report Tracking System (SMARTS) system or use the Office of Water Programs (OWP) online California Phase II LID Sizing Tool- v1.1.

## What are the design criteria for Regulated Projects (>5,000 SF impervious)?

Site design measures must infiltrate, evapotranspire, and/or harvest/reuse for the **85<sup>th</sup> percentile** storm event. **For projects in Santa Clara County, the 85<sup>th</sup> percentile storm event varies based on location.** Projects that increase impervious surface by **more than 50%** must address runoff from the **existing and new** impervious surface. Projects that increase the impervious surface by **less than 50%** of the impervious surface must address runoff from the **new** impervious surface only. If the Runoff Reduction Measures alone cannot address the 85<sup>th</sup> percentile storm event, then the remaining runoff must be addressed through Stormwater Treatment (a bioretention system or another facility demonstrated to be equivalent).

## Are there specific design criteria for different stormwater treatment measures?

Yes. Depending on the measure selected, there are detailed design criteria that must be met. These are described in the Design Criteria Manual. Note the Stormwater Control Plan templates include detailed checklists to be submitted to VTA, along with all sizing calculations used.

## What projects must include Trash Control Measures?

All VTA-owned areas are subject to Trash Control requirements; however, these will vary based on location and annual Trash Implementation Plan monitoring results. **Designers should consult with VTA Environmental Programs staff to determine if trash control measures are required.**





- For VTA projects that have post-construction requirements, Trash Control Measures should be integrated with the drainage design through:
  - Installation of trash full capture systems at storm drains, manholes, or outfalls, wherever feasible. Trash full capture systems must be certified by the State Water Resources Control Board (SWRCB).
  - If full capture systems are infeasible, at a minimum, partial-capture systems, such as retractable screens, must be installed at drain inlets.
  - Installation of 5mm mesh screens at the overflow of stormwater treatment systems (such as bioretention basins).
  - Inclusion of the locations of trash control measures on the project's Stormwater Control Plan Drawings and related CAD Details.
  - Inclusion of language regarding the maintenance of the trash control measures installed in an O&M Plan.

### Is an Operation and Maintenance Plan Required?

Yes, a long-term O&M Plan must be developed by the designer to ensure that post-construction stormwater management features are adequately maintained.

- Plan must include exhibits outlining both surface and subsurface MS4 features and describe procedures necessary to operate and maintain BMPs for a minimum of 5 years..