



# VTA's BART Silicon Valley Phase II Extension Project

Santa Clara  
Community Working Group Meeting

May 16<sup>th</sup>, 2024

# Agenda

- Welcome & Introduction
- Transit-Oriented Communities Grant Update
- Phase II Update
- Santa Clara Design Review Committee Recap
- Early Construction Activities
- Community Engagement
- CWG Member Report Out
- Next Steps

# Santa Clara CWG Members



- Alden Smith, Holland Partner Group
- **Ana Vargas-Smith**, *Reclaiming Our Downtown*
- David Cajigas, *Santa Clara University*
- Grace Davis, *SCU Service & Social Justice (SCCAP)*
- Jack Morash, *South Bay Historic Railroad Society*
- John Urban, *Newhall Neighborhood Association*
- Jonathon Evans, *Old Quad Residents Association*
- Ron Miller, *Bellarmino College Preparatory*
- Ryan Morfin, *San José Earthquakes*
- Todd Trekell, *Hunter Partners*
- *Vacant*, *Silicon Valley Central Chamber of Commerce*

# Upcoming Meetings



- Upcoming CWG Dates
  - Santa Clara CWG Meeting: September 12, 2024
- VTA Board of Directors [vta.org/about/board-and-committees](https://vta.org/about/board-and-committees)
  - Board of Directors' Meeting: June 6, 2024, 5:30 PM
  - VTA's BSVII Oversight Committee: June 13, 2024, 12:30 PM
  - Board of Directors' Meeting: June 28, 2024, 9:00 AM
  - VTA's BSVII Oversight Committee: July 11, 2024, 12:30 PM
  - Board of Directors' Meeting: August 1, 2024, 5:30 PM
  - VTA's BSVII Oversight Committee: August 8, 2024, 12:30 PM
  - VTA Board of Directors' Meeting: September 5, 2024, 5:30 PM
- Kristen will email alerts for other meetings



# Transit-Oriented Communities Grant Update

Melissa Cerezo, VTA

# Transit-Oriented Communities Program - Background



## 2018-2020: VTA TOC Playbooks

- Detailed and implementable recommendations for BART station areas, including addressing displacement of housing and small businesses

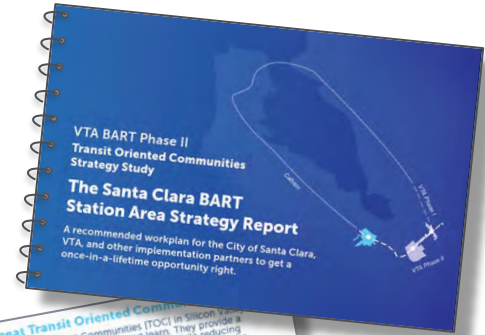

## 2002-2010: Community Design and Transportation Manual

- Design guidelines and capital grant program



# VTA's Transit-Oriented Communities Policy



**Goal:** Increase transit ridership & reduce vehicle trips through intensive mixed-use, mixed-income development around transit stations and corridors.

**Approach:**  
Leverage VTA-owned sites for TOD



Collaborate to accommodate sustainable growth around transit



CURRENT as of 05/16/24 – FOR DISCUSSION ONLY

Address regional priorities



Source: UC Berkley

# Transit-Oriented Communities Program Elements



Grant Partnerships



Regional Leadership



VTA's TOC Grant Program



VTA TOC Working Group



Education and Engagement

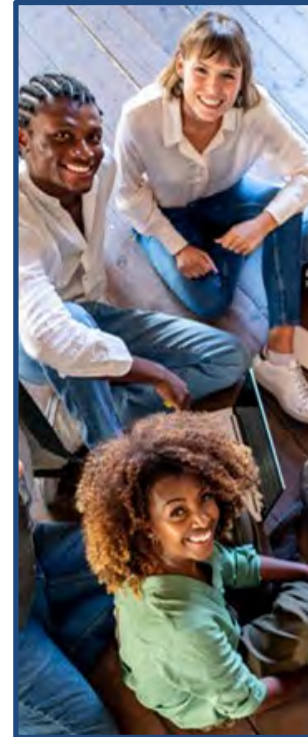







Placemaking and Activation





# Transit-Oriented Communities Grant Program Goals



-  **Increase VTA ridership and active transportation modes**
-  **Advance equity and mitigate displacement**
-  Advance transit-supportive policy alignment
-  Increase community capacity for housing preservation
-  Empower communities to advocate
-  Overcome barriers to equitable engagement
-  Strengthen community culture and identity

# Transit-Oriented Communities Grant Program



\$750,000 in total funding for the following program areas:

**Planning & Policy  
Implementation**



**Community  
Resilience**



**Education &  
Engagement**



**Placemaking, Arts,  
and Activation**





# Phase II Update

Bernice Alaniz, VTA

# FTA/MTC Meetings & Tours



**FTA Region IX Meeting & Tour**  
April 24<sup>th</sup>, 2024

**MTC Walking Tour**  
April 25<sup>th</sup>, 2024



# Program Schedule



*Based on preliminary schedule for planning purposes.*



- Submitted Entry into New Starts Engineering (NSE) application to FTA on March 29<sup>th</sup>
- Met with FTA Administrator, entire Congressional delegation, and senior staff from OMB and Appropriations Committee in Washington, DC
- Review and engagement with FTA's Financial Management Oversight Consultant (FMOC) anticipated
- Regular meetings and reviews with FTA's Project Management Oversight Consultant (PMOC) continue
- Ongoing preparation for Full Funding Grant Application (FFGA) request

# Path to FTA Full Funding Grant Agreement

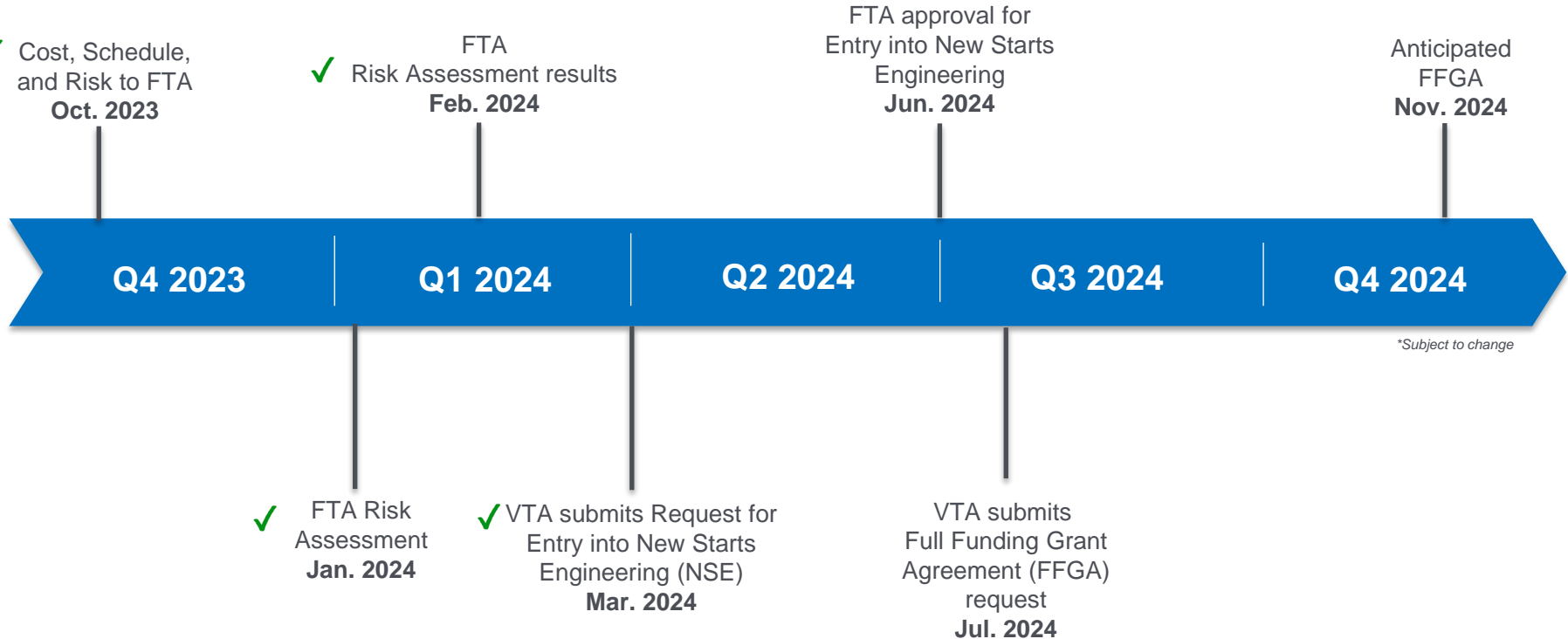

*\*Subject to change*

# NSE Application: Cost Estimate & Funding Plan



FTA Standard Cost Category	Estimate (YOE)
10 - GUIDEWAY & TRACK ELEMENTS	\$2,900
20 - STATIONS	\$2,037
30 - YARDS, SHOPS	\$352
40 - SITEWORK & SPECIAL CONDITIONS	\$582
50 - SYSTEMS	\$1,409
60 - ROW, LAND, EXIST. IMPROV.	\$241
70 - VEHICLES	\$205
80 - PROFESSIONAL SERVICES	\$2,973
90 - UNALLOCATED CONTINGENCY	\$1,657
100 - FINANCE CHARGES	\$390
<b>TOTAL</b>	<b>\$12,746</b>

Notes:

- Costs are rounded to millions
- Reflects FTA-PMOC feedback, including changes to allocated/unallocated contingencies
- SCC 80 includes VTA, BART, Consultants (PMT, GEC, CM, others), OCIP, Third Parties, Legal, CP2 Design, IT, Office leases and other supporting costs.

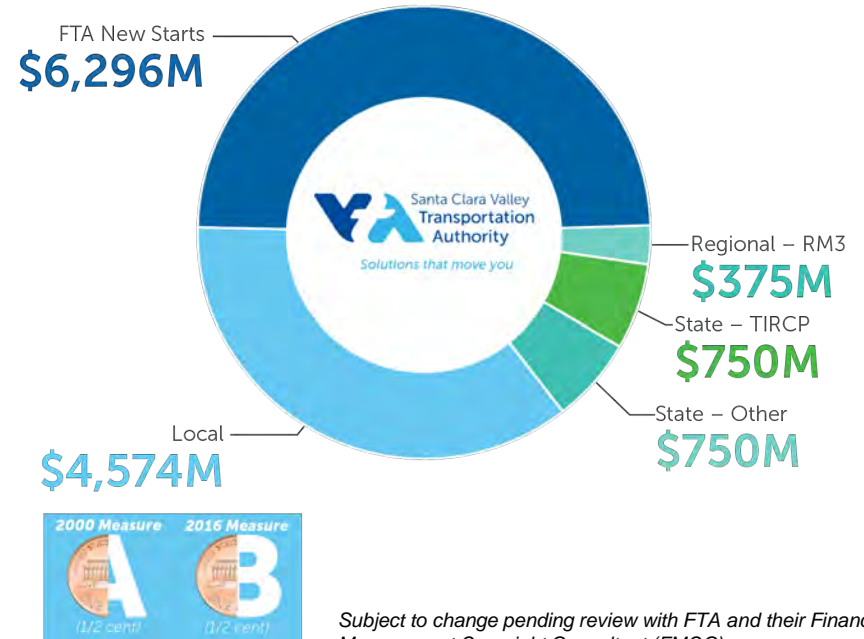

Subject to change pending review with FTA and their Financial Management Oversight Consultant (FMOC)





- **Federal Transit Administration (FTA) announced that \$500 million is officially in the Federal FY24 budget for this project**
- The next six months are very critical for VTA in securing the Federal funding
- Raising project need, benefits, and visibility from a County, State, and Federal level is critical during this period
- Our Congressional Delegation needs to hear about the tremendous support for this Project from all levels of the community – including residents, community stakeholders, businesses, and elected officials
- The project has had strong local backing since 2000 and VTA is here to deliver it

# Project Support and Messaging



## 2024 is Our Year – Tremendous Federal, State, and Local Financial Commitment in the BART Extension Program

- Nearly \$5.8 billion from the state and county is already committed.

## Delivering on the Commitment to the 16-mile Program, Completes the Long-term Vision to "Ring the Bay" with Fast, Frequent Rail Transit

- For the typical 50-mile commute in the Bay Area, taking BART will save riders an average of 30 minutes as opposed to driving.

## Clean, Green Transit Alternative to Major Congested Commute Corridors

- Reduces traffic congestion and delays by providing a practical environmentally friendly alternative to driving.

# Project Support and Messaging



## Delivering Equitable Transit Access

- Ensures easier access to jobs, healthcare and all levels of education



## Affordable Housing for a Diverse Workforce

- Planning for up to 60 million sq. ft. of new commercial and residential development near station areas.



## Sustain and Grow the Silicon Valley Economy

- Every \$1 invested in the project results in \$5 of economic growth
- Expands employment opportunities for two million people in Santa Clara County by providing access to three-and-a-half million Bay Area jobs.



## Job Creation

- Upon completion, the project will have generated 75,000 jobs offering substantial direct and indirect employment opportunities.

# Call to Action



Contact your congressional delegates to share need for the project



Share project updates with your networks through meetings or newsletters

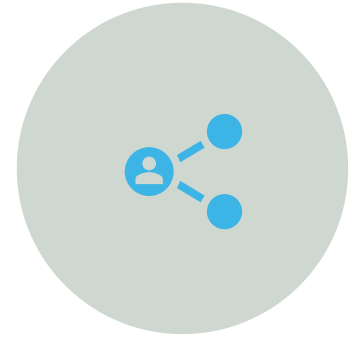

Re-post our project information on your social platforms



# VTA Board Referral

# Board Referral: Updates to Station Design



## VTA Board direction provided at the May 2<sup>nd</sup> Board Meeting

- Provide written report on the stakeholder requests/concerns related to the 28th Street Little Portugal, Downtown San José, and Diridon Stations
- Perform design updates for
  - Above ground facilities at 28th Street Little Portugal Station
  - Added southern entrance at Downtown San José Station
  - Above ground facilities at Diridon Station
- Provide monthly station design updates to VTA's BART Silicon Valley Phase II Oversight Committee.
- **Community Working Group (CWG) meeting process.**
  - Discuss in-person meetings, dedicated staff/consultant support, and review of project documents prior to their presentation to the VTA Board of Directors

*Full Items of Referral can be found listed in the Board Agenda Packet, pg 263-265*



# Community Working Group Discussion & Poll

# Community Working Group Meeting Poll



Would you like to resume in-person CWG meetings? (Select one)

- a) Yes
- b) No



# Community Working Group Meeting Poll



If you would like in-person CWG meetings, how often would you like to attend? (Select all that you prefer)

- a) I would commit to meeting in-person for **every meeting**
- b) I would commit to meeting in-person for **every other meeting**
- c) I would commit to meeting in-person for **one meeting each year**
- d) I'd prefer to keep meeting **virtually** on Zoom
- e) I prefer to have an option between in-person & virtual

# Community Working Group Meeting Poll



I like the current meeting format with staff facilitation (Select one)

- a) Yes
- b) No

I would prefer a shift in meeting format towards external facilitation (Select one)

- a) Yes
- b) No

# Community Working Group Meeting Poll



Would you be interested in a pre-meeting networking time with CWG members, Project staff, and invited presenters? (Select one)

- a) Yes
- b) No

Would you like to review Project documents prior to the presentation at the Board of Directors meeting? (Select one)

- a) Yes
- b) No

Any other feedback to provide on the CWG meetings?



# Santa Clara Design Review Committee Recap

Erica Roecks, VTA

# DRC Station Design Considerations



Feature Wall Plaza and Bow Truss Canopy



Orchard Pavilion and Extended Canopy





	Summer 2024	Q3 2024	Q4 2024
<b>Community Engagement</b> – Online and in-person engagement	✓		
<b>DRC Member Recap</b> – Provide results from community engagement and next steps		✓	
<b>Further DRC Discussions</b>			✓

- Public engagement of station aesthetic elements planned for Summer 2024.
- Community will have opportunity to provide feedback both online and in person on the aesthetic and design elements discussed within the DRCs.



# Early Construction Activities

Erica Roecks, VTA

# Initial Activities at West Portal



- Site grading began in May and may produce vibrations and noise during the day.
- Where applicable, BSV is facilitating ongoing construction coordination and updates between contractor and stakeholders.
- CTMP covering this work was brought to Councils and approved in June 2023.



# Anticipated Early Construction Work Hours\*



Hauling	Construction Activities**
6:00 AM-4:00 PM	6:00 AM-6:00 PM

\*Consistent with approved CTMP Early Works Hours

\*\*Construction activities are planned for Monday-Friday; Saturday activities as needed

# Overview of What to Expect

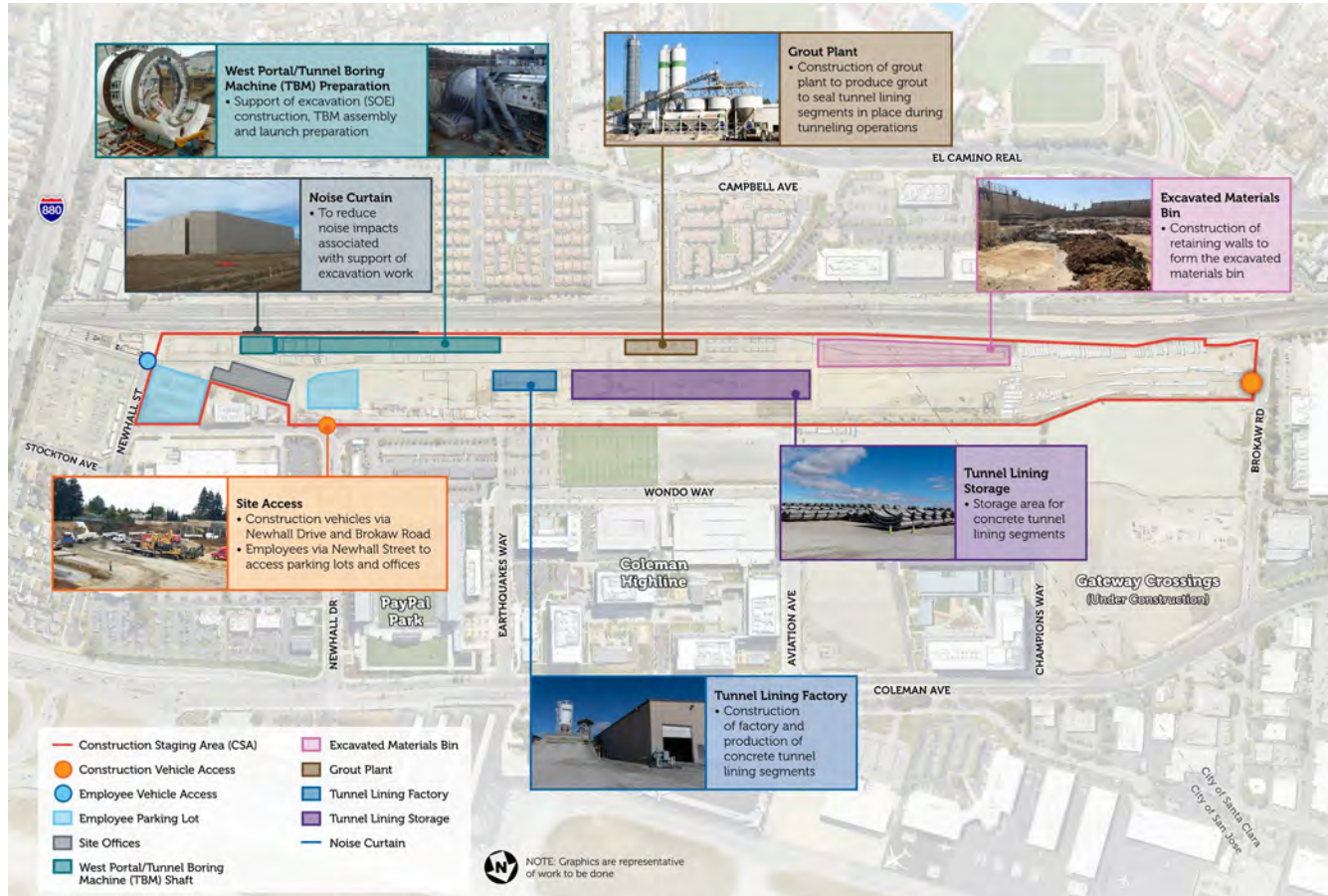

# Initial Early Construction Activities



- Civil site work, including:
  1. Wheel Washing, Water Trucks, Street Sweeping
  2. Establishing entry and exit points
  3. Noise & Vibration monitoring
  4. Grading
  5. Fencing, gates and barriers
  6. Security, signage and striping
  7. Temporary offices and parking
  8. Installation of temporary construction utilities
  9. Paving

# Fence Removal and Installation



## Fence Removal



## Fence Installation

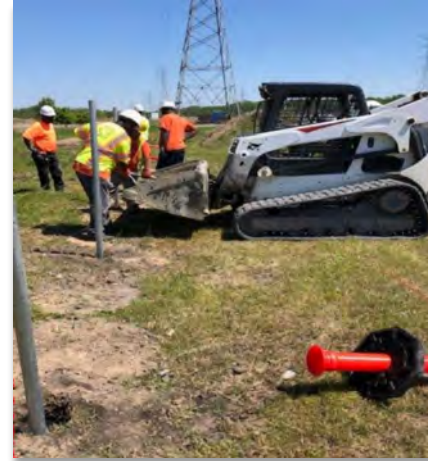

# Air Monitoring Action Plan



- Follow measures recommended by Bay Area Air Quality Management District (BAAQMD)
- All off-road Diesel equipment shall have EPA Tier IV Engines – Clean Emissions
- Continuous equipment maintenance and inspection
- General Rule for Dust – No visible dust crossing property line
  - Watering trucks
  - Street sweepers – continuous
  - Vehicles speed on site enforced <15 mph
  - Water applied daily to grading operation and stockpiled soil
  - Posted signage with Hotline phone number
  - Prolonged disturbed soil will be covered with Geo-grid fabric or applied soil binder
  - Moisten/cover haul trucks to prevent dust emissions
  - Suspending dust-intensive activities in high winds



# West Portal Construction Screening



# Tunnel Boring Machine (TBM) Purchased



- VTA purchased its TBM in November 2023
- The \$76M TBM will be one of the largest machines ever to be built
- Official TBM naming contest closed 4/29, with winning name announced in Summer 2024

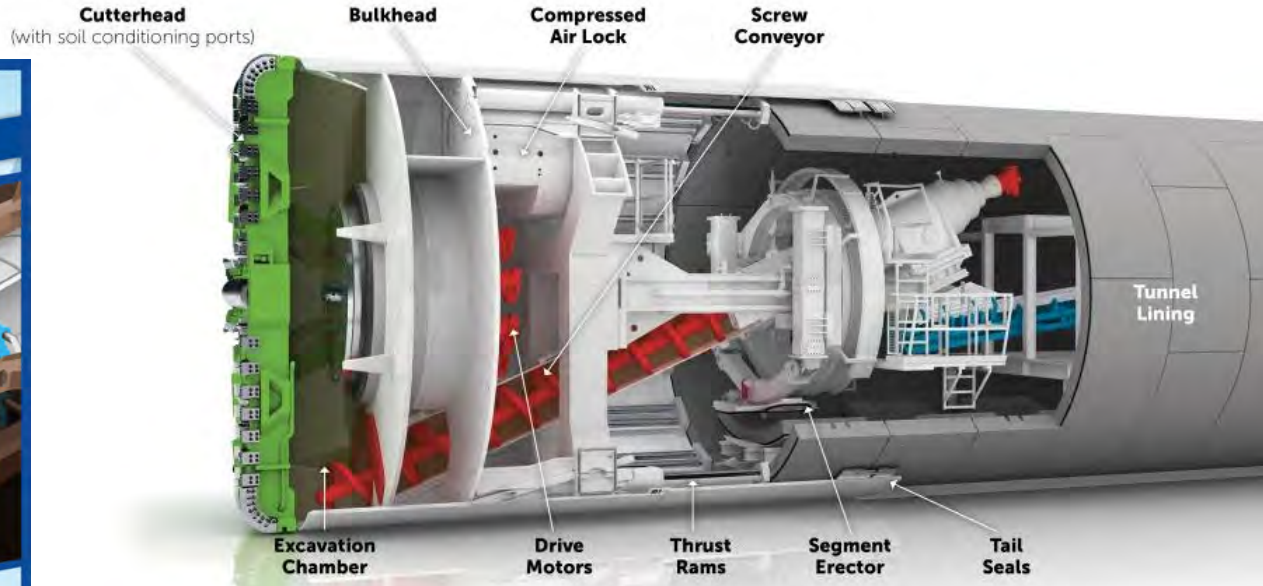



- **WHAT** – summary of construction activity
- **WHERE** – location of construction activity with map
- **WHEN** – include interval of dates and times, include a note if it includes weekend and/or nighttime work
- **WHAT TO EXPECT** – includes information on the activity and impacts (noise, dust, sidewalk closures, parking impacts, bus stop relocations, road detours, etc.)



# Example of a Construction Notice



## VTA's BART Silicon Valley Phase II Extension Project



### Notice of West Portal Site Work: Week of April 22, 2024

#### WHAT

- To assist in the beginning of construction work at the West Portal site within the future Newhall Yard & Maintenance Facility, VTA's BART Silicon Valley Phase II (BSVII) project workers will be on site the week of April 22, 2024, to install project equipment comprised of noise, vibration, and air quality monitors.
- The Newhall Neighborhood may witness BSVII project workers within the neighborhood to install project equipment on the Dahlia Loop and De Altura Common, for no more than 2-4 hours at a time.

#### WHERE

- The West Portal site within the future Newhall Yard & Maintenance Facility.
- Newhall Neighborhood roadways including Dahlia Loop and De Altura Common.

#### WHEN

- All work will be conducted between 9 am and 5 pm, from Monday, April 22, 2024 – Friday, April 26, 2024.

#### WHAT TO EXPECT

- BSVII project construction workers to be onsite at variable hours the week of April 22 to install construction equipment.

#### PROJECT BACKGROUND

VTA's BART Silicon Valley Phase II Extension (Phase II Project) is a six-mile, four-station extension of BART from Berryessa / North San José Station (opened 2020) through downtown San José to the City of Santa Clara. The Phase II Project is planned to include an approx. five-mile subway; three stations with underground platforms (28th Street/ Little Portugal, Downtown San José, and Dardon), one ground-level station (Santa Clara), a train maintenance and storage facility, and additional facilities.



 Area of project equipment installation

*Construction is a dynamic process and information is subject to change without notice.*



VTA's BART Phase II Hotline  
(408) 321-2345  
(408) 321-2330 TTY

[vta.org/bart](http://vta.org/bart)  
[vtabart@vtabsv.com](mailto:vtabart@vtabsv.com)

[@vtabsv](https://www.facebook.com/vtabsv)  
[@vtabsv2](https://twitter.com/vtabsv2)  
[@vtabsv2](https://www.instagram.com/vtabsv2)



## Electronic Distribution

- Email:
  - Distribute via MailChimp to all stakeholders
  - CWG members, City districts, neighborhood associations, targeted stakeholders (e.g., PayPal Park), residents
  - Renotify electronically if changes to start dates
- Post on Project website and Social media
- VTA inputs information in transit apps, 511 & mapping apps
- VTA notifies transit riders for bus stop relocations, etc.



## Physical Distribution

- Physical flyers are distributed to businesses/residences/etc. within a 1,000 ft. radius of the construction activity



# Community Engagement

Matt Derby, VTA

# 2024 Tabling Engagement



**Milpitas Station Pop-up** – January 25<sup>th</sup>, 2024

**Lunar New Year Festival** – February 17<sup>th</sup>, 2024

**Transit Day Meta** – February 27<sup>th</sup>, 2024

**VTA ACCESS Paratransit Open House** –  
February 29<sup>th</sup>, 2024

**Biblioteca Latinoamericana Refresh** –  
March 9<sup>th</sup>, 2024

**Spring Train Show** – April 6<sup>th</sup>, 2024

**5WUVP Open House** – April 20<sup>th</sup>, 2024

**Viva Calle SoFA** – April 21<sup>st</sup>, 2024

**4<sup>th</sup> Annual SCU PowWow** – May 4<sup>th</sup>, 2024

**1,413** total engagement interactions in 2024!

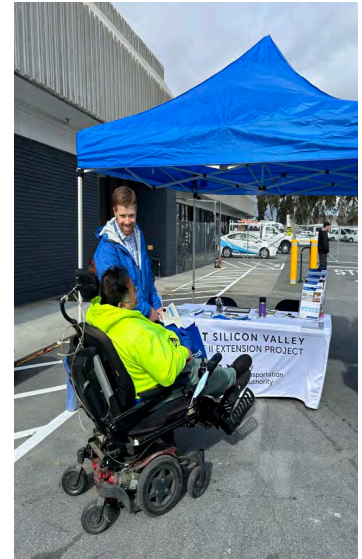

# Upcoming Community Engagement



- **June 8, 2024:** East Bay Regional Connector Project Groundbreaking Event
- **June 8, 2024:** Dia de Portugal



# New BSVII Project Website



- Phase 1 of new Project website set to launch in May
  - Will include webpages on transparency, the Project, a resource library, and FAQs
- Phase 2 of new Project website set to launch in June 2024
  - Will include webpages on construction, the Business Resource Program, and community activity
  - Will include an interactive construction map and Shop Local Marketing map to highlight small businesses

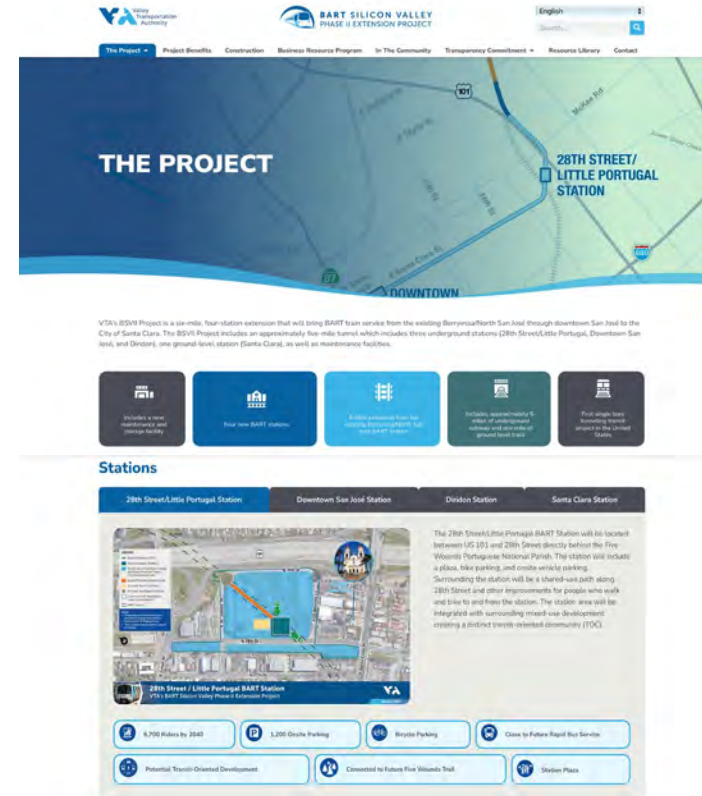



# Ongoing/Upcoming Activities Spring & Summer 2024

Start of Early Works  
Construction at Newhall  
Yard and Maintenance  
Facility  
**Late April 2024**



Business Resource Program  
Launch  
**June 2024**



**Q2 2024**

**Q3 2024**

*\*Subject to change*

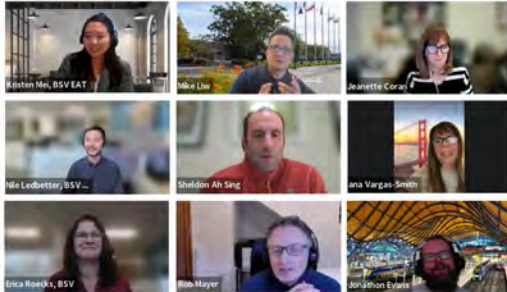

Design Review  
Committees  
**Late Spring 2024**

Online & Pop-Up Event  
Community Engagement  
**Summer 2024**



# VTA's Official TBM Naming Contest



- Contest closed 4/29
- **Name Criteria:** Female name (or a representative name) that has significance to Santa Clara County.
- **732** names were submitted!!
- **Next Steps:** TBM Naming committee (made of BSV and City staff) will recommend name for General Manager to approve
- **Name Announced** next month





# West Portal Groundbreaking Event



CWG Members invited!

**YOU'RE INVITED!**

**West Portal Groundbreaking Event**

Valley Transportation Authority

**BART SILICON VALLEY  
PHASE II EXTENSION PROJECT**

**2024**

**Friday, June 14, 2024  
10 AM – Noon**

VTA's Newhall Yard  
Entrance at 480 Brokaw Road,  
Santa Clara, CA

*Celebrate the start of construction for the project that will "ring the Bay" with fast, frequent, high-quality passenger rail service!*



- **BRP Soft-Launch (Late-June 2024)**
  - BRP Section on the New Project Website and Social Media
  - BRP Canvassing Kit
  - Business Liaison Team
  - BRP Media Launch
  - Small Business Task Force
  - Businesses Community Workshop
- **Financial and Technical Assistance (Fall 2024)**
  - Community-Based Organization (CBO) Engagement
  - CBO Survey & Business Outreach Survey
  - Direct Financial Assistance (DFA) Program Launch (2025)

# Opportunities for Project & Construction Updates



## Interactive Efforts



Tabling events throughout the year around the station areas



Community Working Group meetings



Public Meetings



Community Group Meeting Outreach

- Reach out to have us present updates at your local Community Group/Neighborhood Association/etc. [www.vta.org/about/subscribe](http://www.vta.org/about/subscribe)

## Resources



VTA's hotline number: **408-321-2345**

- Call to learn more about specific project efforts and provide your feedback



VTA's website: **[vtabart.org](http://vtabart.org)**

Sign up to get alerted on nearby construction and find Informational Factsheets, Newsletters, and Blog Posts



Email questions to: **[vtabart@vtabsv.com](mailto:vtabart@vtabsv.com)**

Social Media



Twitter: **[@vtabsv2](https://twitter.com/vtabsv2)**  
Facebook: **[@vtabsv](https://www.facebook.com/vtabsv)**  
Instagram: **[@vtabsv2](https://www.instagram.com/vtabsv2)**



# CWG Member Report Out

# Report Back – Santa Clara



- Alden Smith, Holland Partner Group
- **Ana Vargas-Smith**, *Reclaiming Our Downtown*
- David Cajigas, *Santa Clara University*
- Grace Davis, *SCU Service & Social Justice (SCCAP)*
- Jack Morash, *South Bay Historic Railroad Society*
- John Urban, *Newhall Neighborhood Association*
- Jonathon Evans, *Old Quad Residents Association*
- Ron Miller, *Bellarmino College Preparatory*
- Ryan Morfin, *San José Earthquakes*
- Todd Trekell, *Hunter Partners*
- *Vacant*, *Silicon Valley Central Chamber of Commerce*

How have you been sharing information and updates on BSVII with your community?

What have you heard from your communities?

# Next Steps

- Next CWG meeting:  
**September 12<sup>th</sup>, 2024**
  - Phase II Update
  - Early Construction Activities Update
  - Community Engagement
  - Station Area Planning & Adjacent Developments